



UFS



Planning aids and basic knowledge

Underfloor systems

Building Connections





**Contact
Customer Service
+49 23 73 89 - 17 00**

Service times
Monday to Friday 09.00 to 18.00

+49 23 73 89 - 12 38

**export@obo.de
www.obo-bettermann.com**







Contents of planning and mounting aids

	Planning and mounting aids	6
	EÜK screed-covered duct system	24
	Open trunking system, screed-flush OKA	50
	OKB brush bar trunking system	76
	System 55 for thin screed layers	90
	IBK in-concrete duct system	102
	On-floor trunking system AIK and Telitank	116
	GES service outlets	126
	Cassettes – height-adjustable and decouplable	148
	Heavy-duty systems	170
	UDHOME floor sockets and floor boxes	184
	GES R2 floor sockets	198
	Modul 45[®] and standard installation solutions for underfloor systems	212
	Modul 45connect[®] plug-in installation solutions for raised and cavity floors	234
	Fire protection for underfloor systems	250
	Additional information	254



**ACKERMANN
MADE BY OBO**



Underfloor systems from Ackermann made by OBO offer solutions for electrical installations in the floor. The electrical installation duct and trunking systems on offer are suitable for mounting in screed or concrete. A wide range of device installation units gives the user access to power, data and multimedia connections.

Underfloor systems guarantee safe, flexible cable routing in the floor, taking the structural and standardisation requirements into account. The area of application for underfloor installation ranges from office and administrative buildings, through commercial exhibition areas right up to the construction of living accommodation. There is a range of installation solutions to meet the many construction and extension specifications.



Planning and mounting aids

Installation requirements

The following belong to the installation requirements to be taken into account when planning and selecting an underfloor system:

- Number of services (power, communications, data)
- Filling factor of the electrical installation ducts and trunking
- Cable bend radii
- Reserve
- Concurrency factors
- Planned for indoor use

Requirements from construction planning

The architectural building planning produces, amongst other things, the following preconditions:

- Type of room (dry or wet)
- Floor covering version (dry or wet-cleaned)
- Thickness of the floor covering
- Type and version of the screed
- Traffic loads
- Ambient temperature (underfloor heating)
- Indoors

Organisational requirements

Areas of application and user requirements with regard to electrical installations determine the organisation requirements for an underfloor system. This produces, amongst other things, the following criteria:

- Flexibility of use (e.g. simple adaptation to changing use specifications)
- Easy changing of device equipment
- Use of fixed or movable installations

Safety requirements

The topic of safety is playing an ever-more important role, particularly in the data technology sector. Therefore, when selecting and designing an underfloor installation, this point can also be of importance. This is the case, for example, when data networks must be protected against unauthorised access.

Trunking and duct systems

The cables are routed in electrical installation duct and trunking systems. Ackermann made by OBO can offer various systems, which are suited to different applications and structural requirements.

EÜK

Screed-covered duct system, EÜK

The screed-covered duct system is suitable for all screed types in all routing types, also in hot screed. The electrical installation ducts form a tight, hidden cable routing grid in the screed. Underfloor sockets allow the expansion with device installation units and access to the electrical installation.

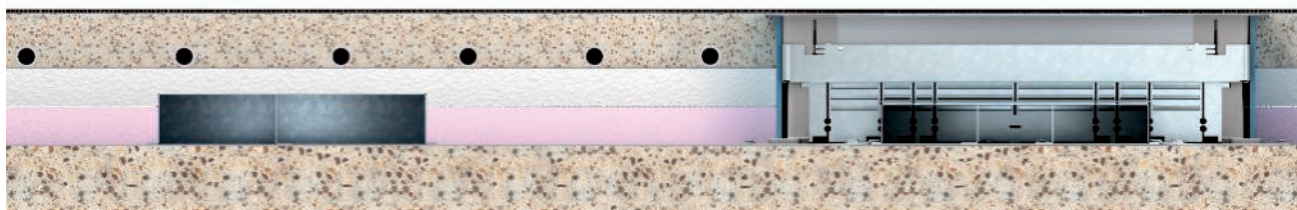

OKA

Open trunking system OKA

The electrical installation trunking can be adjusted to the millimetre to the upper edge of the screed. OKA trunking is suitable for screeds in all routing types, with the exception of heated screed. The benefit in terms of changes of room use is that the screed-flush electrical installation trunking can be opened along its entire length, allowing flexible cable routing. Depending on the screed height, device installation units are either installed in the trunking route or in extension units which are mounted at the side.



OKB

Open trunking system OKB

The OKB trunking system uses the trunking sections for cable routing and as installation space for electrical installations. The OKB trunking is suitable for routing in front of floor-height windows or walls. Cables exit via a surrounding brush bar. The trunking can be set exactly at the top edge of the screed, to the millimetre, and can be opened along the entire length.

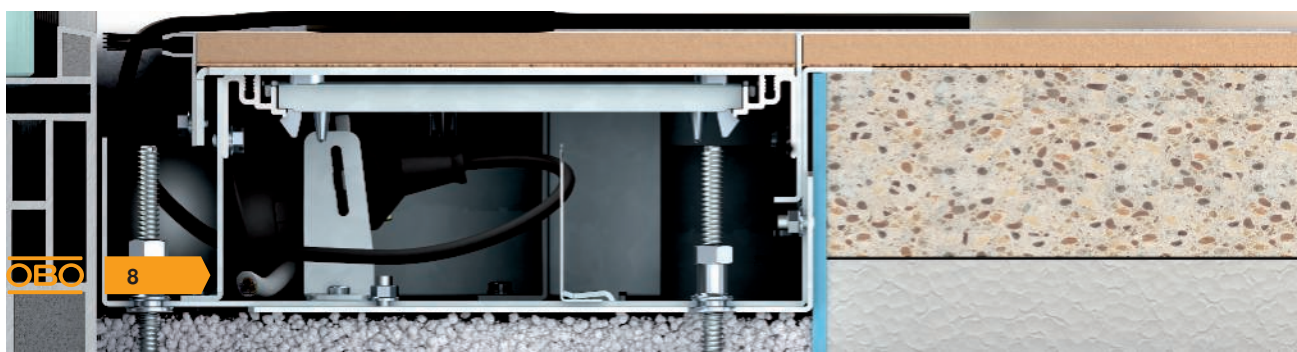

IBK

In-concrete system IBK

The IBK system is used in buildings with concrete core activation or direct use of the concrete surface, for example with high loads. The IBK duct system is installed in the raw building when creating the floor plates or raw concrete screed.



System 55

System 55 for thin screed layers

Low floor structure heights require special solutions for underfloor installations. System 55 is used for screed heights of 55 mm or higher.



AIK

On-floor trunking system AIK

The AIK on-floor trunking system is installed on the finished floor. The system is particularly useful in places where classic underfloor systems cannot be installed, such as during building renovation, particularly in listed buildings. Device installation units above the floor (Telitanks) are used for the installation of electrical devices.



Screed structure



Nominal screed thickness for EÜK screed-covered duct system

An important precondition for a proper underfloor installation is the screed structure. In the case of a screed-covered system, it is important that the screed thickness over the duct corresponds to the values in the standard, to avoid the formation of cracks. The nominal screed thickness is dependent on the insulation layer, the individual load and the screed type. More detailed information on the nominal thickness of the screed in Germany can be found in DIN 18560.

Here, under certain circumstances, chemical or thermal loads may occur, which require special additional measures to protect the mounted system.

The OKA and OKB screed-flush trunking systems, as well as the UZD underfloor box, only obtain their load capacity for correct use when jointed to the neighbouring screed.

The following points are, therefore, important:

- The duct system may not be walked upon or subjected to similar loads after it has been mounted on the raw concrete
- The duct system must form a composite system with the adjacent screed

The following points should particularly be taken into account with the OKA and OKB system:

- Line the side profiles with screed to achieve good static support in the screed. The screed should be worked and compacted carefully
- The opened trunking system may not be walked upon nor subjected to similar loads. Measures to provide suitable protection should be agreed with the works supervisor



Use in floating screed

When using screed-covered duct and screed-flush trunking systems in float finishes, seal off any openings in the duct and trunking systems using suitable agents (e.g. adhesive tape). In so doing, ensure that the sealing process does not create any cavities between the components and the screed.

With screed-covered duct systems, openings may be created through duct joints on connecting shackles and vertical bends and on the underfloor socket bodies. In addition, the top ends such as the mounting protection lid, mounting lid and the blanking lid should be covered or stuck down using suitable means.

With screed-flush trunking systems, openings may be created through joints of the trunking units, at junctions, extension units and end sections and at the transition of the trunking bases to the side profiles. The side profiles and lid joints on the trunking covers should also be covered.

Use in poured asphalt

When using electrical installation duct systems in poured asphalt, it is important to protect the duct system against the impact of heat.

The screed-covered ducts may not, under any circumstances, have a direct connection with the poured asphalt. The high installation temperature of approximately 250 °C means that changes to the shape of metallic parts cannot be ruled out. An insulation layer, e.g. made of Fasoperl plates or bitumen corrugated card, protects the duct sections from the impact of heat.

Also, the screed-flush trunking may not, under any circumstances, have a direct connection with the poured asphalt. Screed anchors are the exception here. An approximately 15–20 mm thick insulation strip is fastened to both sides of the trunking before the poured asphalt is added. After cooling, the insulation strip between the trunking and the screed plate is removed and filled using a suitable casting compound.

Aggressive screed (e.g. magnesia screed)

All the metallic parts coming into contact with an aggressive screed must be protected during construction using a tested epoxy resin-based corrosion protection agent. A second coating is required.

Determining the cable volume

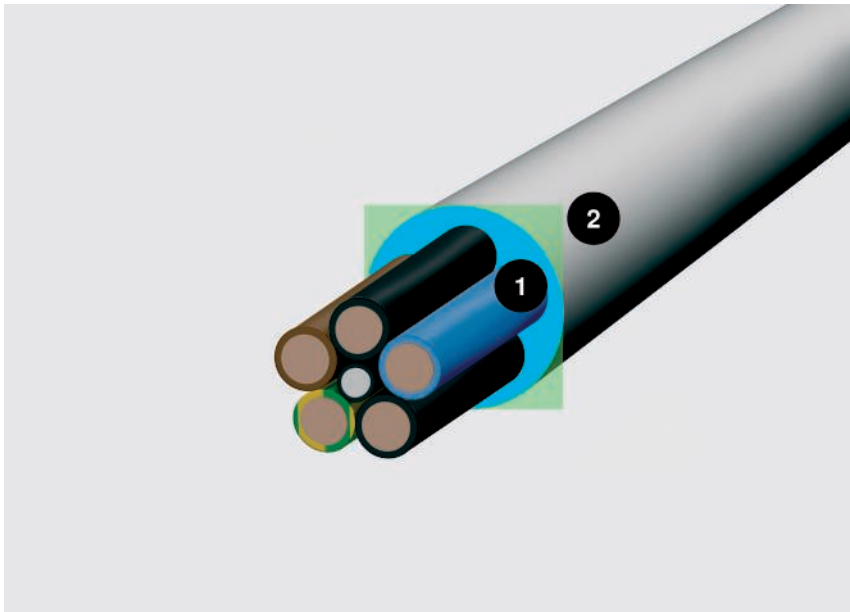

Cable diameter and space required: 1 = diameter in mm, 2 = space required in cm²

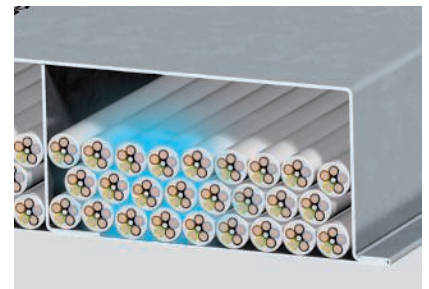

The space requirements of the cables in the UFS ducts with empty spaces

The cable volume is an important criterion for the selection of the required duct size of the underfloor system. To simplify your work, we have listed the diameter and space requirements of the most important cable types on this double page.

Important: These values are average values, which may vary from manufacturer to manufacturer. Please refer to the manufacturer's specifications for the exact values.

Calculation with the formula $(2r)^2$

As the cables are never packed tightly together or absolutely parallel, it is not enough to base the volume calculation solely on the cable diameter. A realistic calculation is provided by the formula $(2r)^2$. This value reflects the realistic space requirements, including the compartments.

Cable volume

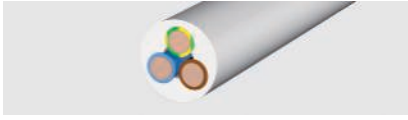

Insulated power cables

Type	Diameter mm	Usable cross-section cm ²
1 x 4	6.5	0.42
1 x 6	7	0.49
1 x 10	8	0.64
1 x 16	9.5	0.9
1 x 25	12.5	1.56
3 x 1.5	8.5	0.72
3 x 2.5	9.5	0.9
3 x 4	11	1.21
4 x 1.5	9	0.81
4 x 2.5	10.5	1.1
4 x 4	12.5	1.56
4 x 6	13.5	1.82
4 x 10	16.5	2.72
4 x 16	19	3.61
4 x 25	23.5	5.52
4 x 35	26	6.76
5 x 1.5	9.5	0.9
5 x 2.5	11	1.21
5 x 4	13.5	1.82
5 x 6	14.5	2.1
5 x 10	18	3.24
5 x 16	21.5	4.62
5 x 25	26	6.76
7 x 1.5	10.5	1.1
7 x 2.5	13	1.69

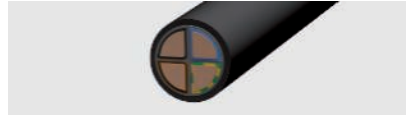

Insulated power cables

Type	Diameter mm	Usable cross-section cm ²
1 x 10	10.5	1.1
1 x 16	11.5	1.32
1 x 25	12.5	1.56
1 x 35	13.5	1.82
1 x 50	15.5	2.4
1 x 70	16.5	2.72
1 x 95	18.5	3.42
1 x 120	20.5	4.2
1 x 150	22.5	5.06
1 x 185	25	6.25
1 x 240	28	7.84
1 x 300	30	9
3 x 1.5	11.5	1.32
3 x 2.5	12.5	1.56
3 x 10	17.5	3.06
3 x 16	19.5	3.8
3 x 50	26	6.76
3 x 70	30	9
3 x 120	36	12.96
4 x 1.5	12.5	1.56
4 x 2.5	13.5	1.82
4 x 6	16.5	2.72
4 x 10	18.5	3.42
4 x 16	21.5	4.62
4 x 25	25.5	6.5
4 x 35	28	7.84
4 x 50	30	9
4 x 70	34	11.56
4 x 95	39	15.21
4 x 120	42	17.64
4 x 150	47	22
4 x 185	52	27
4 x 240	58	33.6
5 x 1.5	13.5	1.82
5 x 2.5	14.5	2.1
5 x 6	18.5	3.42
5 x 10	20.5	4.2
5 x 16	22.5	5.06
5 x 25	27.5	7.56
5 x 35	34	11.56
5 x 50	40	16



Telecommunications cables

Type	Diameter mm	Usable cross-section cm ²
2 x 2 x 0.6	5	0.25
4 x 2 x 0.6	5.5	0.3
6 x 2 x 0.6	6.5	0.42
10 x 2 x 0.6	7.5	0.56
20 x 2 x 0.6	9	0.81
40 x 2 x 0.6	11	1.12
60 x 2 x 0.6	13	1.69
100 x 2 x 0.6	17	2.89
200 x 2 x 0.6	23	5.29
2 x 2 x 0.8	6	0.36
4 x 2 x 0.8	7	0.49
6 x 2 x 0.8	8.5	0.72
10 x 2 x 0.8	9.5	0.9
20 x 2 x 0.8	13	1.69
40 x 2 x 0.8	16.5	2.72
60 x 2 x 0.8	20	4
100 x 2 x 0.8	25.5	6.5
200 x 2 x 0.8	32	10.24



Coax cable (standard)

Type	Diameter mm	Usable cross-section cm ²
SAT/BK cable	6.8	0.48



IT cables type Cat...

Type	Diameter mm	Usable cross-section cm ²
Cat. 5	8	0.64
Cat. 6	8	0.64

Device installation units

Device installation units offer installation space for power, data and multimedia connections in the floor structure. Various solutions are available, depending on the application.

GES service outlets

The GES service outlets are the tried-and-trusted solution for office installations with carpeted floors. They are available in plastic or metal. The service outlets possess countless intelligent details, such as cable routing clips, carpet protection frames, reliable edge protection and a locking lid closure system with automatic lid opening.



Cassettes

The compact, floor-flush cassettes can be adjusted to the height of the floor and can be completely decoupled from the socket base. Cassettes are particularly suitable for floor coverings such as tiles or parquet. There are various versions for dry, moist and wet-cleaned floor coverings. Stainless steel and brass not only look good, they also provide lasting quality.



08_UFS / en / 2019/07/18 10:39:53 (LLExpert_02520) / 2019/07/18 10:40:17 10:40:17

GES R2 floor sockets

The OBO GES R2 floor sockets are an ideal under-floor solution, when a discreet appearance, a high load capacity and varied functionality are required. Their handling is simple: Pipelines are inserted in the compact installation space and that space is closed off with a lid. The installation socket of the GES R2 floor sockets is pre-equipped with two sockets. To the side of the socket, there is space for up to two connection sockets for data technology applications, as an option.



UDHOME floor sockets and floor boxes

Completely pre-equipped mounting units are available under one order number. The floor sockets and floor boxes of the UDHOME family are mounted directly on the raw concrete and connected with flexibly installation pipes – it couldn't be simpler.



Modul 45® devices

For maximum flexibility, the device installation units can, depending on requirements, be equipped with the comprehensive Modul 45 series from OBO Bettermann or with standard installation devices. Both sockets and data and multimedia technology of the Modul 45 series are simply snapped in, without tools, making work quicker and thus cheaper.



Selection of the right device installation units

IP protection class to EN 50085-2-2

Electrical installation duct and trunking systems and device installation units can be used only in interior areas of buildings and, depending on the construction type, in dry, moist or wet-cleaned floors. The cleaning type of the floor covering is the decisive criterion for the selection of the matching device installation unit. The matching of the device installation unit to the floor care type ensures that the

electrical installation is protected against the ingress of moisture and dirt.

Ackermann made by OBO device installation units are tested according to EN 50085 and labelled appropriately. With a protection rating of at least IPx4 when closed, all the device installation units for wet-cleaned floors completely fulfil the requirements of EN 50085-2-2.

Device installation units with tube

body also protect the electrical installation against the ingress of water when used – despite a reduced protection level of IP20. The tube body ring meets the standard requirements to EN 50085-2-2 and protrudes 10 mm above the top edge of the floor covering. Up to this height, puddles or waves of water cannot ingress into the installation compartment.

IK protection types

The IK classification to EN 50102 grades the mechanical stability of electrical installation duct and trunking systems.



Protection ratings to IP and IK for device installation units

	IP when used	IP when unused	IK
Plastic GES	20	40	08
Stainless steel GESM	20	40	10
Metal GRAF9	20	65	10
Cassette, cord outlet RKS	20	40	10
Cassette, tube body RKF	20	65	10
Cassette, blank	20	65	10
UDHOME	20	40	10
UDHOME tube body	20	65	10
GES R2 metal	20	66	10
GES R2 plastic	20	40	10

Dry cleaning

Textile floor coverings, cleaned by sucking up the dirt without or with only a little fluid, are considered as dry-cleaned. If a cleaning solution is used, then the dosage must be so low that there is no chance of puddle formation or saturation of the floor covering.

Moist cleaning

Smooth floor coverings such as linoleum, PVC, sealed wooden floors or polished stone floors fulfil the requirements for moist cleaning. The building cleaning trade defines this type of cleaning as a dust-collecting wipe using moist or prepared cleaning textiles.

Wet care

Wet cleaning occurs primarily with stone floors, tiles, ceramic floors, linoleum and PVC. This cleaning method removes particularly tough and bonded soiling.

In the first step, cleaning textiles apply as much cleaning fluid as is necessary to soften and dissolve strongly adhering soiling. In the second step, the remaining fluid and soiling is wiped up using cleaning textiles.

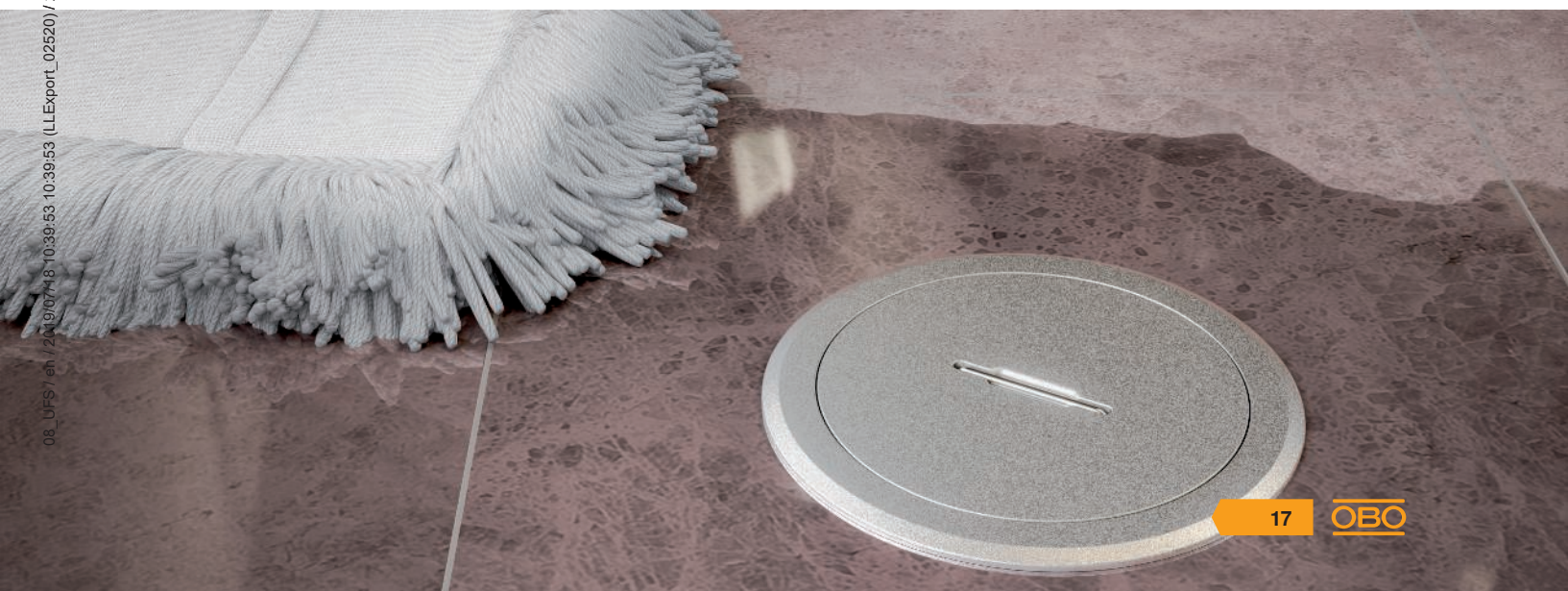

Standardisation and testing

Responsibilities in standardisation

Standards can be divided into two categories: Erection specifications and device testing specifications. The installation engineer is primarily responsible for compliance with the erection specifications. In Germany, the standards of the DIN VDE 0100 series define the most important requirements for electrical installations.

European standardisation

Device testing specifications are product standards, which specify the testing criteria for specific products. The manufacturer is responsible for compliance with these regulations. Conformity with a specific testing specification is often documented by a symbol approval certificate. This confirms that an independent testing and certification institute has carried out the appropriate tests and documented the results.

Device testing specifications are particularly important for:

- Safety (protection against electric shocks)
- The definition of the areas of application
- The function definition
- The evaluation of load capacities

The standard EN 50085 defines the requirements for electrical installation duct systems. Part 2-2 deals with underfloor and on-floor systems and was published in July 2009. Underfloor systems from Ackermann made by OBO meet EN 50085-2-2 and have the corresponding VDE certificates of approval.

Classification for underfloor systems

EN 50085-1, as a general part for electrical installation trunking systems, and EN 50085-2-2, as a system-specific part for underfloor systems, both require classification of the products. This means there is a standard Europe-wide specification of product properties. For the first time, a standard for installation systems also contains optional load tests for vertical loads, which affect a large area (heavy load).



Classification to EN 50085-1

6.1	According to material
6.2	According to impact resistance
6.3	According to temperatures
6.4	According to the resistance to flame propagation
6.5	According to the electrical conductivity
6.6	According to electrical insulation capability
6.7	According to the protection ratings offered by the housing or casing to EN 60529:1991
6.8	According to protection against corrosive or impure substances
6.9	According to the fastening type of the system duct cover
6.10	According to the electrical protection separation

Classification to EN 50085-2

6.101	Depending on the type of floor care
6.102	According to resistance to vertical loads affecting a small surface area
6.103	Optional classification according to resistance to vertical loads affecting a large surface area

Installation specifications

Erection regulations are used particularly for:

- Safety (protection against electric shocks)
- The maintenance of electrical functionality
- Electromagnetic compatibility
- Fire prevention

The erection specifications according to DIN VDE describe numerous points, which the electrical installation engineer must take into account when setting up and mounting an underfloor system. Here are some of the most important points:

Mechanical loads of cables

According to DIN VDE 0298, with heavy current and data cables it must be ensured that specific values for strain loads and bend radii are not exceeded. The standard also describes the approved cable fastening types with clips and strain reliefs.

Protective measure and equipotential bonding

Metallic duct systems must be included in the protective measure and the equipotential bonding. This should thus ensure the protection against electric shocks to DIN VDE 0100-410 and the electromagnetic compatibility to EN 50310, EN 50173, EN 50174-2.

Separation of different services

According to DIN VDE 0100-520, cables of different current types may be installed together in a routing system if all the cables are insulated against the next highest occurring voltage.

Fire protection

The main cause of fire in heavy current cables are

- high-resistance short circuits or faults to earth, e.g. on mechanically or thermally damaged cables
- faulty electrical connections, e.g. due to a loose contact
- heat build-ups

The spreading of fire and smoke into other fire sections must always be prevented over a sufficiently long period of time. This supports both attempts to escape and also extinguishing measures. This also applies to underfloor systems which run under fire section and emergency and escape routes. The cable system directives (M)LAR and the system floors directive (M)SysBöR regulate this in greater detail.

Heavy current cables and other electrical resources in underfloor installations

Select the size of the electrical installation ducts so that the required number of cables can be routed without damage.

When selecting the heavy current cables for routing in electrical installation ducts, observe DIN VDE 0100, particularly Part 520. With regard to the current carrying capacity of heavy current cables, see DIN VDE 0100 Part 430 and Part 523 and DIN VDE 0298, particularly Part 4.



Equipotential bonding in underfloor systems

According to EN 50085, electrically conductive electrical installation duct systems and their expansion components must offer the connection options to be included in the equipotential bonding of a building.

The inclusion in the equipotential bonding prevents dangerous potential differences according to DIN EN 50310. All the underfloor systems from Ackermann made by OBO are equipped in such a way that inclusion in the protection measure is possible without a great amount of work.

The protective conductor connection bracket 8AWR, for example, can be used to include a duct system in the equipotential bonding. The protective conductor connection bracket is inserted in the existing installation markings or in appropriate grooves. The fastening screw must be tightened with a torque of at least 1.2 NM. The clamping range is designed for two connection cables of 1.5 to 4 mm².

DIN EN 50174-2 (VDE 0800-174-2) "Information technology – Cabling installation" requires the inclusion of conductive installation systems in the additional functional equipotential bonding up to the connection point. This equipotential bonding does not serve as protective equipotential bonding, but serves as functional equipotential bonding for EMC protection.

The electrical planner and the electrical installation engineer is responsible for the implementation of the protective measure and compliance with the erection requirements valid on-site.

Inter-unit work

The electrical installation engineer should arrange the coordination of inter-unit work with the responsible construction management, in order to guarantee flawless mounting of the electrical installation duct systems, along with quality across all the construction sections.



Screed work

Screed-flush trunking systems and the underfloor boxes of the screed-covered duct system serve as a binding draw-off gauge for the screed. The adjustment height of the system components is aligned to the structural specifications of the construction management.

In the area of the draw boxes and the ducts, the person laying the screed must carefully work, compact and draw-off the screed.

Screed can be destroyed by crack formation. To avoid crack formation, adjacent screed-flush systems and system components may not be subjected to loads before final hardening.

Floor covering work

The company laying the floor covering is responsible for ensuring that the floor covering is cut out exactly and adjusted to the sockets and outlet points of the duct system. The joint dimensions must be matched with the construction management. The lids of the screed-flush underfloor boxes and trunking must be covered with floor covering. Carpets used must be securely laid and resistant to cuts.

Building cleaning

Particularly during first cleaning of the floor areas, device installation units must be carefully cleaned free of building dust and other impurities, in order to prevent impairment of their function.

During the use phase, device installation units must be checked for correct use and possible damage, in order to avoid subsequent damage.

In particular, device installation units for wet-cleaned floors (e.g. tube body cassettes, GRAF9 or GESR2) must be maintained regularly and the function of the seal checked. For this, regular lubrication of the seal is required.

Noise prevention and impact noise

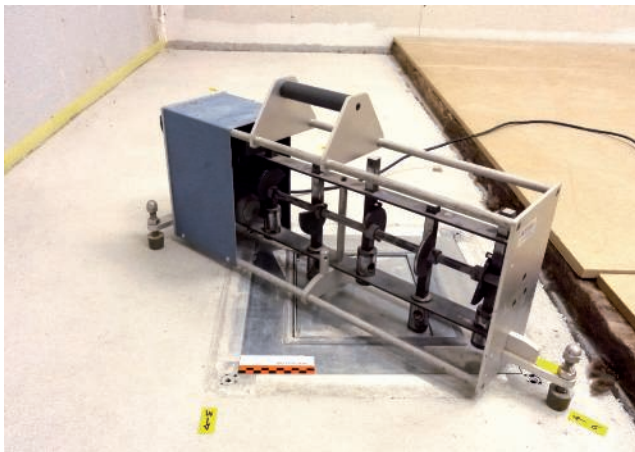

The underfloor systems from Ackermann made by OBO are, amongst other things, intended for installation in floating wet screeds. Normally, there are requirements for the transmission of air and footfall sound, both for vertical sound transmission, i.e. from storey to storey, and for horizontal sound transmission, i.e. from adjacent rooms.

As the underfloor systems are also run under partitions, there is frequently the question of the influence of the system on noise transmission. These influences were evaluated in qualified tests to determine the transmission of air and footfall sound carried out together with the MÜLLER BBM GmbH testing institute in Planegg, Munich, for the EÜK duct and OKA, OKB trunking systems and the UDHOM4 floor boxes.

For office buildings, a distinction must be made between the binding construction law requirements to DIN 4109 [4], which must be observed with regard to air and footfall sound insulation between foreign areas of use, and between the recommendations for protection against air and footfall sound in the same office, e.g. to Supplementary Sheet 2 for DIN 4109 [4] or the VDI directive 2569 [5]. The VDI directive 2569 is currently being revised.

The following table summarises the requirements of DIN 4109 [4] and the recommendations according to Supplementary Sheet 2 of DIN 4109.

Component	Evaluated noise insulation dimension R'w in dB to DIN 4109 and Supplementary Sheet 2 to DIN 4109	Evaluated noise insulation dimension R'w in dB to DIN 4109 and Supplementary Sheet 2 to DIN 4109
Ceilings		
Separating ceilings within own use areas	52...55	46...53
Separating ceilings between other use areas (construction law requirement)	54...55	53
Walls¹		
Walls between rooms with normal office activities or between corridors and such rooms	37...42	-
Walls between training rooms or similar and between corridors and such rooms	47	-
Walls of rooms for concentrated mental work or for dealing with confidential matters or walls between corridors and such rooms	45...52	-
Doors²		
Doors in corridor partitions of rooms with usual office activity	27	-
Doors in corridor partitions of training rooms	32	-
Doors in corridor partitions of rooms for concentrated mental work or for dealing with confidential matters	37	-

¹ Without taking doors into account.

² With doors, the evaluated sound insulation dimension R'w applies as the value for sound insulation for sole transmission through the door in a function, installed state.



Planning checklist

The following topics should be observed for the correct installation of an underfloor system and may need to be agreed with different units:

- ✓ Adjustment of the specified cutting check with the construction management for checking of the raw building dimensions and for the adjustment of the duct system's height
- ✓ Testing of the mounting surface for uneven areas to 18202 Tab. 3
- ✓ The mounting area must be protected against weather and be free of rubble and foreign bodies, i.e. have been swept clean
- ✓ Observation of fire protection directives, load requirements and impact sound measures
- ✓ Detailed routed diagram including positioning of the necessary system components
- ✓ Parameters for floor structure, floor type and cleaning, screed height
- ✓ Parts list of the articles used in the project
- ✓ Floor design of the responsible architect



EÜK screed-covered duct system

The EÜK screed-covered duct system from Ackermann made by OBO is the ideal electrical installation system for large areas with fixed furnishing plans, for example in office or administration buildings. Duct sections and underfloor boxes form a tight grid, hidden in the screed, for cable routing. When combined with device installation units, access is given to power, data and multimedia technology.

OBO
BETTERMANN



Wide range of uses

The EÜK system is suitable for all screed types, e.g. for cement screeds, poured asphalt, floating screeds or heated screeds. The completely closed duct system protects the routed cables and repels footfalls, dust and dirt during everyday construction site work.

Depending on the construction project, the system offers solutions for floor structures with increased load requirements and for dry, moist and wet-cleaned floor coverings.

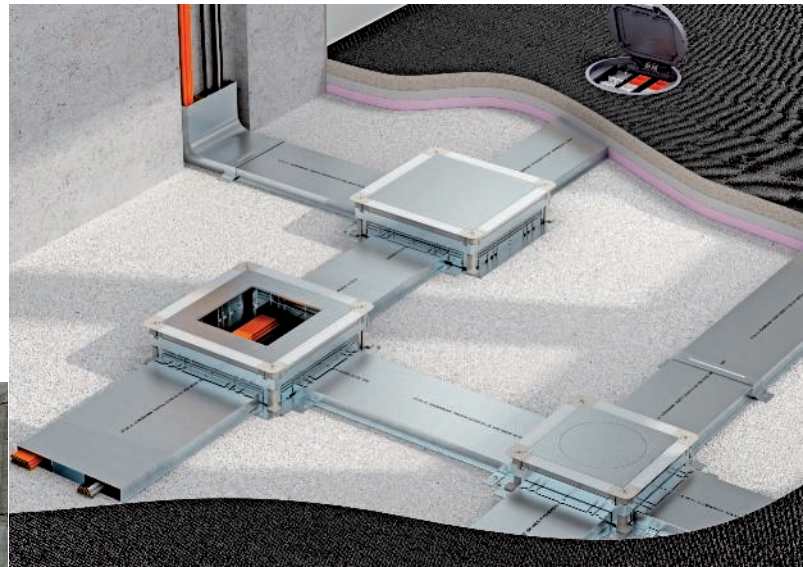

Ideally suitable for wet cleaning



Suitable for the highest loads and expandable as a heavy-duty system



In use around the world for decades

Quality at every level

The ducts and underfloor boxes of the EÜK system are mounted directly on the raw concrete. To protect against heat losses and the reduction of footfall sound, insulation layers are inserted, which surround the duct system completely.

Optionally, underfloor heating can be installed for wide-area heat distribution and is then covered by the screed. The screed thickness above the duct is to be specified in accordance with DIN 18560.

Combination with underfloor heating

The EÜK system is ideally suited to installation in floors, in which there is underfloor heating in the screed. The duct system is below this and is thus completely separate in the insulation layer.

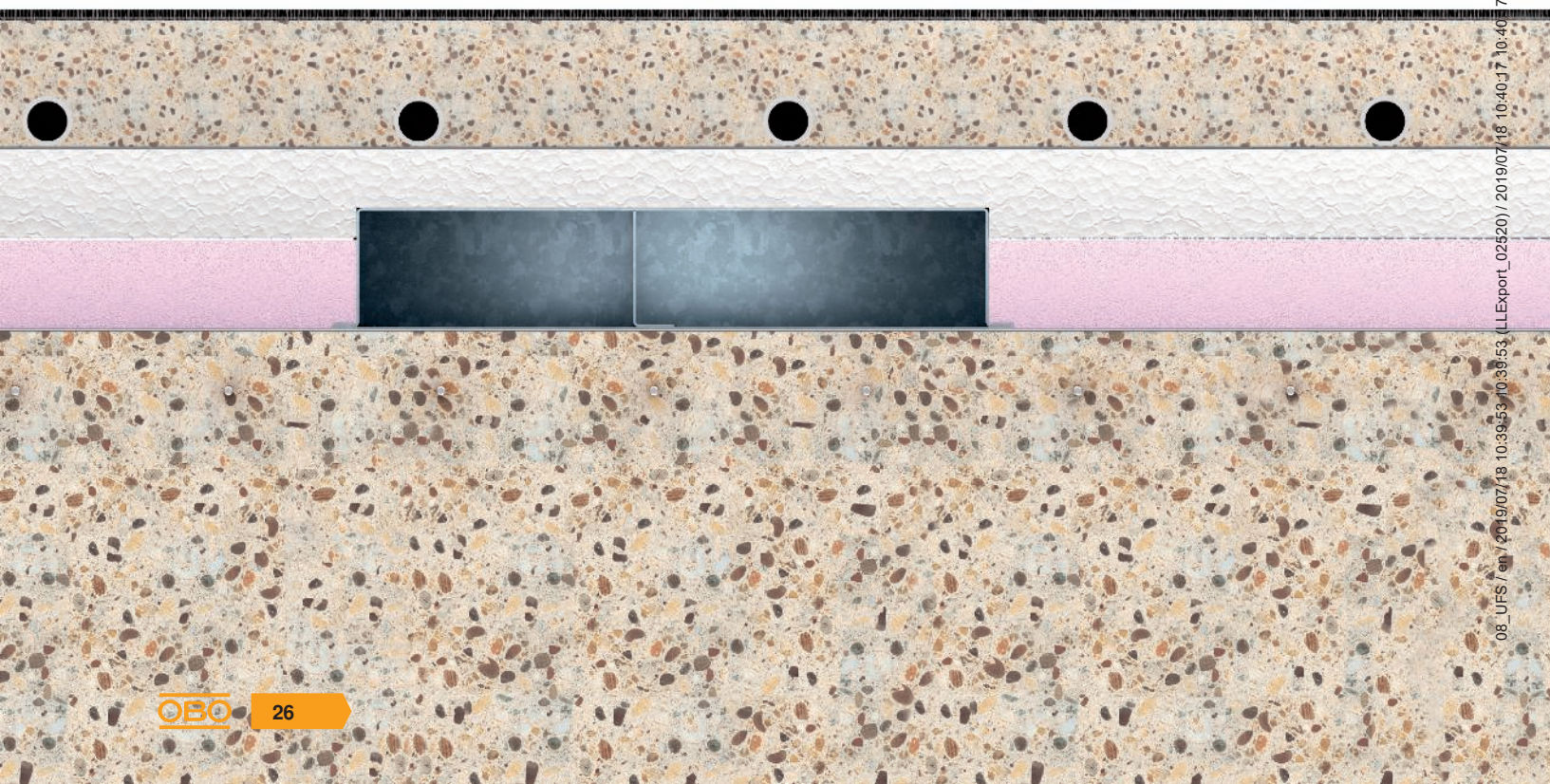
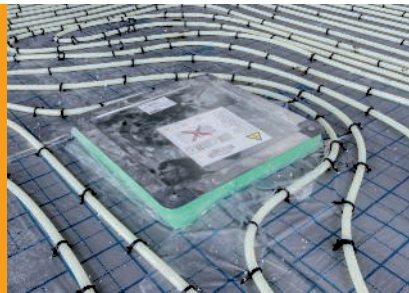



Large height-adjustment range

The underfloor boxes in the three basic heights cover a height-adjustment range of between 70 and 220 mm screed height. At low screed heights of 55 mm or more, System 55 is used, whilst, with high floor structures, the underfloor boxes can be raised to up to 320 mm.



Tested quality

The load capacity of the EÜK system has been tested to DIN 50085-2-2. In its own BET Test Centre, OBO also carries out its own load tests for the system. Thus, even special solutions can be tested within a short time.



Practical – all over the world

The EÜK system is one of the most popular underfloor systems. Planners around the world rely on its variety, reliability and flexibility. Thus, in cooperation with OBO, numerous challenging construction projects have been completed. This is also because we make special demands of our products.

Thus, for example, the covers and accessory parts in the heavy-duty sector offer continuously high levels of stability – well beyond those required by the standard. According to DIN EN 50085-2-2, temporary bending by 6 mm is permissible. However, in practice, such severe bending can lead to damage, depending on the floor covering. Thus, we use practice-orientated benchmarks to check that the products can stand up to all the requirements on the building site and during later use.



1-08_UFS / en / 2019/07/18 10:39:53 10:39:53 J.Export_02520 / 2019/07/18 10:40:17 10:40:17



ACKERMANN
MADE BY OBO



Experts in the under-floor sector

The EÜK system was the first underfloor system as we know it today in Europe. The system was presented for the first time in 1965 and, since then, has been continually adapted to installation practices. For five decades, planners, architects and customers have relied on the tried-and-trusted technology for creating a high level of flexibility in underfloor electrical installations.

Installation of the system components

Vertical bend

The matching vertical bends allow the creation of vertical changes of direction, e.g. as a connection to wall connections or supplies.



System sizes, ducts

The ducts are available in the heights 28, 38 and 48 mm, and in the widths 190, 250 and 350 mm. Fixed sheet steel separating retainers divide the ducts up into two or three duct compartments.

Underfloor accessory socket



The underfloor box (UGD) is intended for device installation. It is supplied with a mounting lid and a lid blanking plate. Depending on the version, it is designed for the installation of round or rectangular installation units.

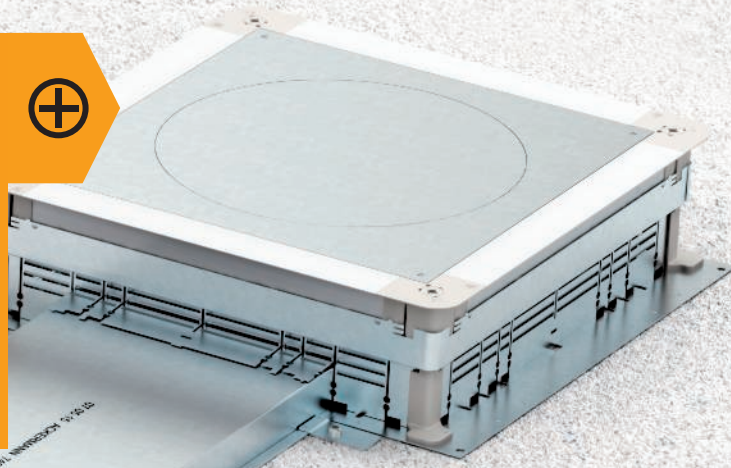

Underfloor junction and branch box

The underfloor draw and junction box (UZD) serves as the access point to the electrical installation in the ducts. It can be equipped with a mounting lid for device installation.

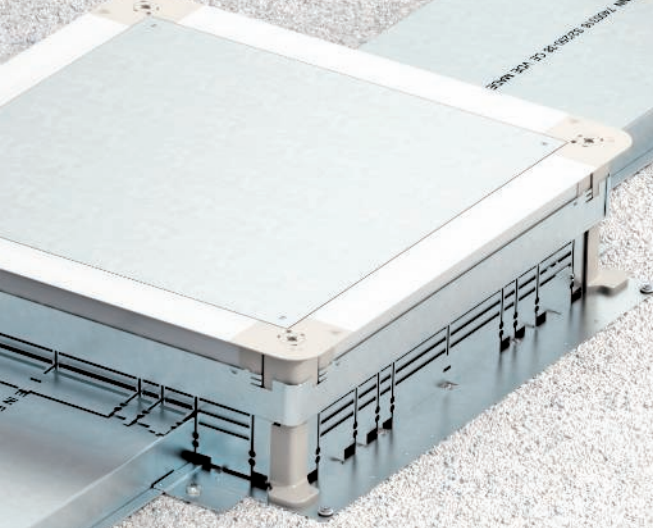

Equipotential bonding

Connection shackles create a conductive connection between the two inserted pieces of duct.



System sizes, underfloor boxes



The type UZD and UGD underfloor boxes are available in two system sizes:

- System size 250 (367 x 410 mm)
- System size 350 (467 x 510 mm)



Robust and easy to mount

The underfloor boxes of the EÜK system possess an extremely robust socket body. They are ideally suited to construction site operation with its dirt, dust and being stepped upon. Installation is easy thanks to the practical rapid height adjustment and the large, tidy installation space.

Height adjustment



The underfloor boxes have a minimum structure height of 70 mm and a height-adjustment range of an additional 55 mm.

The height adjustment takes place in two stages: Firstly, the underfloor box is roughly pre-adjusted to the screed height using the integrated quick height-adjustment function. In the second step, the fine adjustment to the top edge of the screed is carried out using a screwdriver.

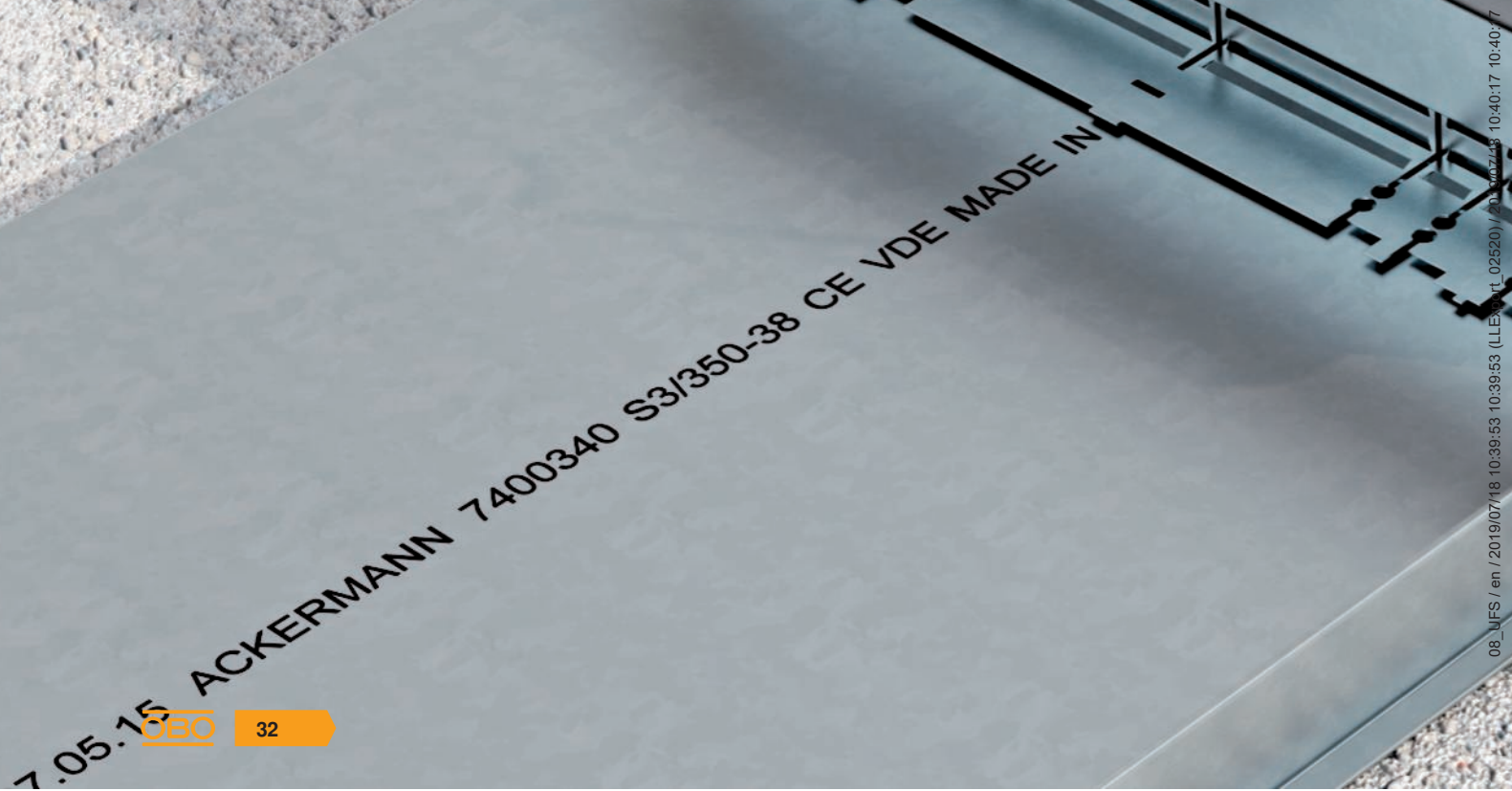

08_UFS / en / 2019/07/18 10:39:53 (LLEB...L_02520) / 20...002743 10:40:17 10:40:17



Completely reliable

The sidewalls of the underfloor boxes are made of galvanised sheet steel. Their stable corner elements are made from die-cast zinc. On the surface, stable aluminium profiles provide an elegant, load-bearing end.



Closed

The solid system shows its strengths during the construction phase. It is always completely closed. The underfloor boxes are protected from above by the mounting protection lid. Thus, no foreign bodies can ingress and the interior remains clean.



Range of functions – a fixed point

When installed, the underfloor box is securely anchored in the screed. The screed can be worked particularly well around the drip edge of the socket, which also serves as a broad support in the screed.

Large, protected installation space

The underfloor boxes of the EÜK system possess completely closed metallic sidewalls. Thus, the installation space remains tidy and also offers plenty of space for cable routing. The full height is available for installations.



CKERMANN 7400340 S3/350-38 CE VDE MADE IN

Noise protection

After screed laying, the top frame of the underfloor box can be decoupled from the box base. The frame then floats on the screed plate, without any connection to the raw concrete. The complete decoupling of the top frame of the box and the resulting separation from the concrete means that no noise is transmitted via the duct system and the underfloor boxes.

This means that the noise insulation damping of the floating screed is not impaired by the EÜK system. This has been proven by a noise protection survey of the EÜK system.



Wide support in the screed

The cover of the underfloor box has a wide aluminium profile, which is positioned in the screed. This gives the entire socket an especially high level of stability, preventing damage to the floor covering.

The stable aluminium profiles at the edge of the socket serve as a drip edge for the screed and permit exact installation.

Flexible equipment

Device installation units, in the form of cassettes and service outlets, can be installed in underfloor boxes with a mounting lid. The device installation units accept sockets, data and multimedia connections.

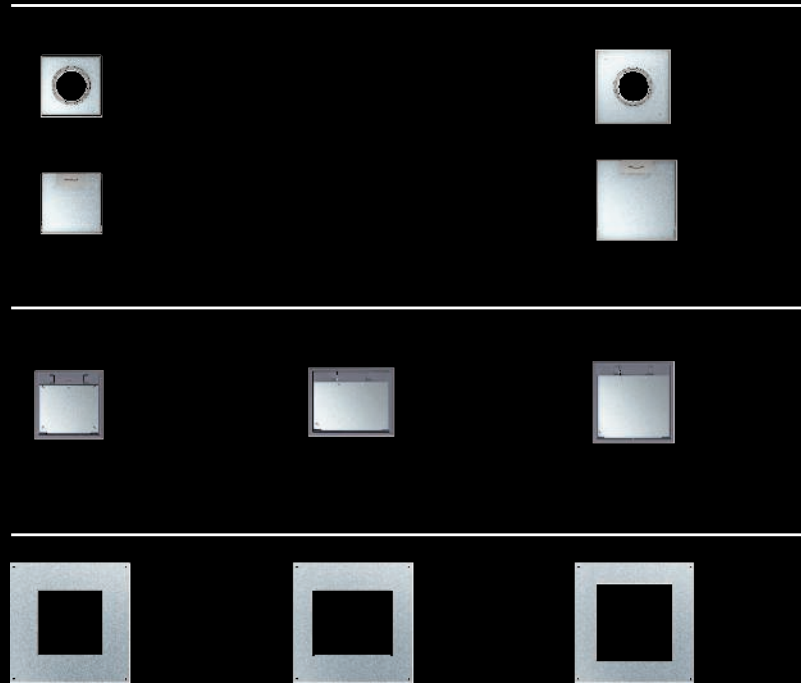

New installation

With the matching mounting lid, it is possible to install service outlets in the rectangular systems sizes 2, 4, 6 and 9 and in the round system sizes R4, R7 and R9. In addition, a blind lid and a lid for the mounting of Telitanks (units protruding above the floor) are available.



Cassettes*



Service outlets*



Mounting lid*

*You can find our complete product range in the product section of our underfloor systems catalogue.

Change of use

If there is a change of use, the screed-flush sockets offer direct access to the electrical installation and they can be adjusted appropriately. The mounting lid can be replaced: Later installation of a service outlet of another shape is thus no problem.

Installation principle, screed-covered duct system

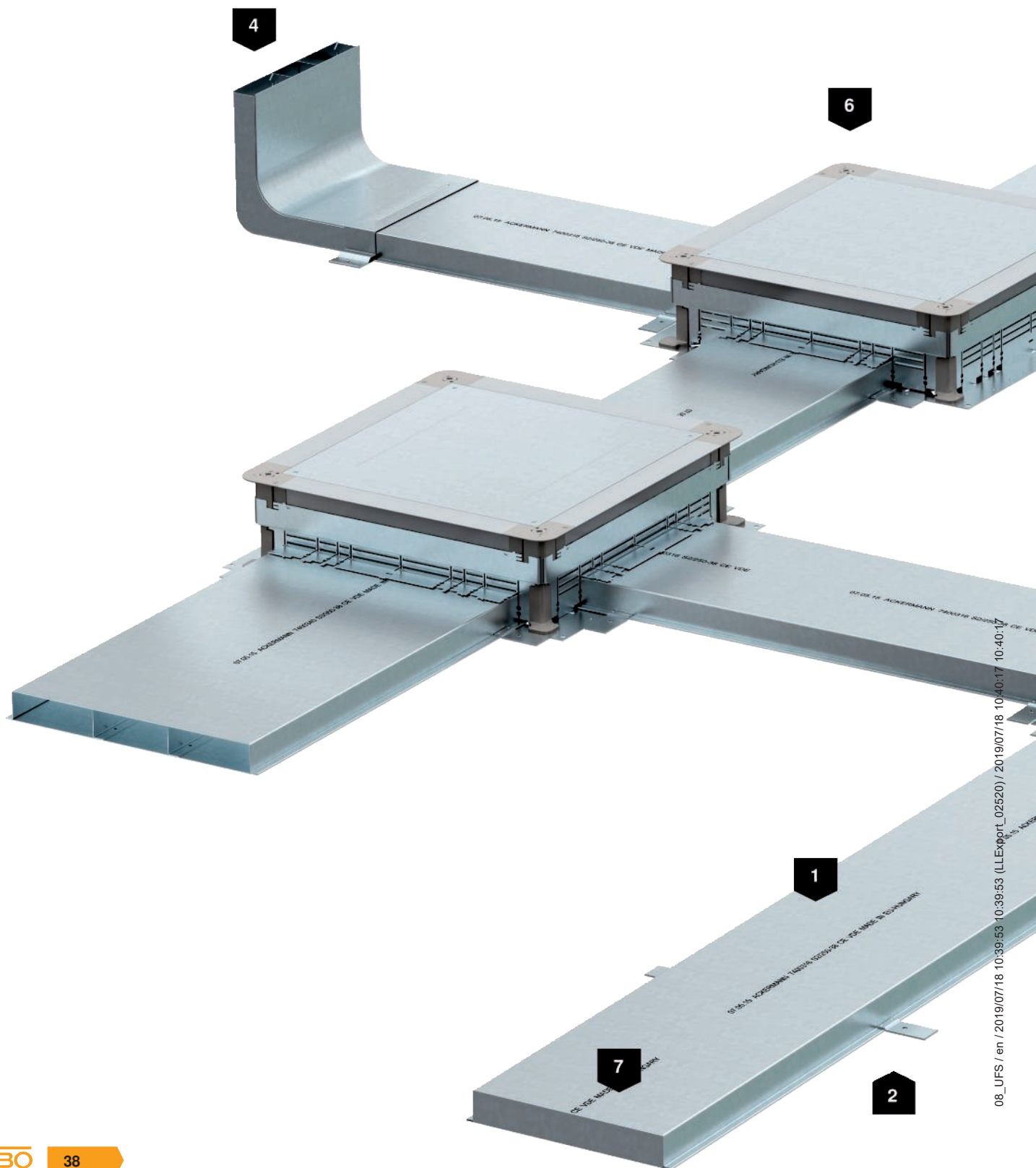

08_UFS / en / 2019/07/18 10:39:53 (LLExpert_02520) / 2019/07/18 10:40:17 10:40:17

1	Underfloor installation duct
2	Duct connection bracket
3	Connection shackle
4	Vertical bend
5	Underfloor box with mounting lid and lid blanking plate (UGD)
6	Underfloor junction and branch box (UZD)
7	End piece

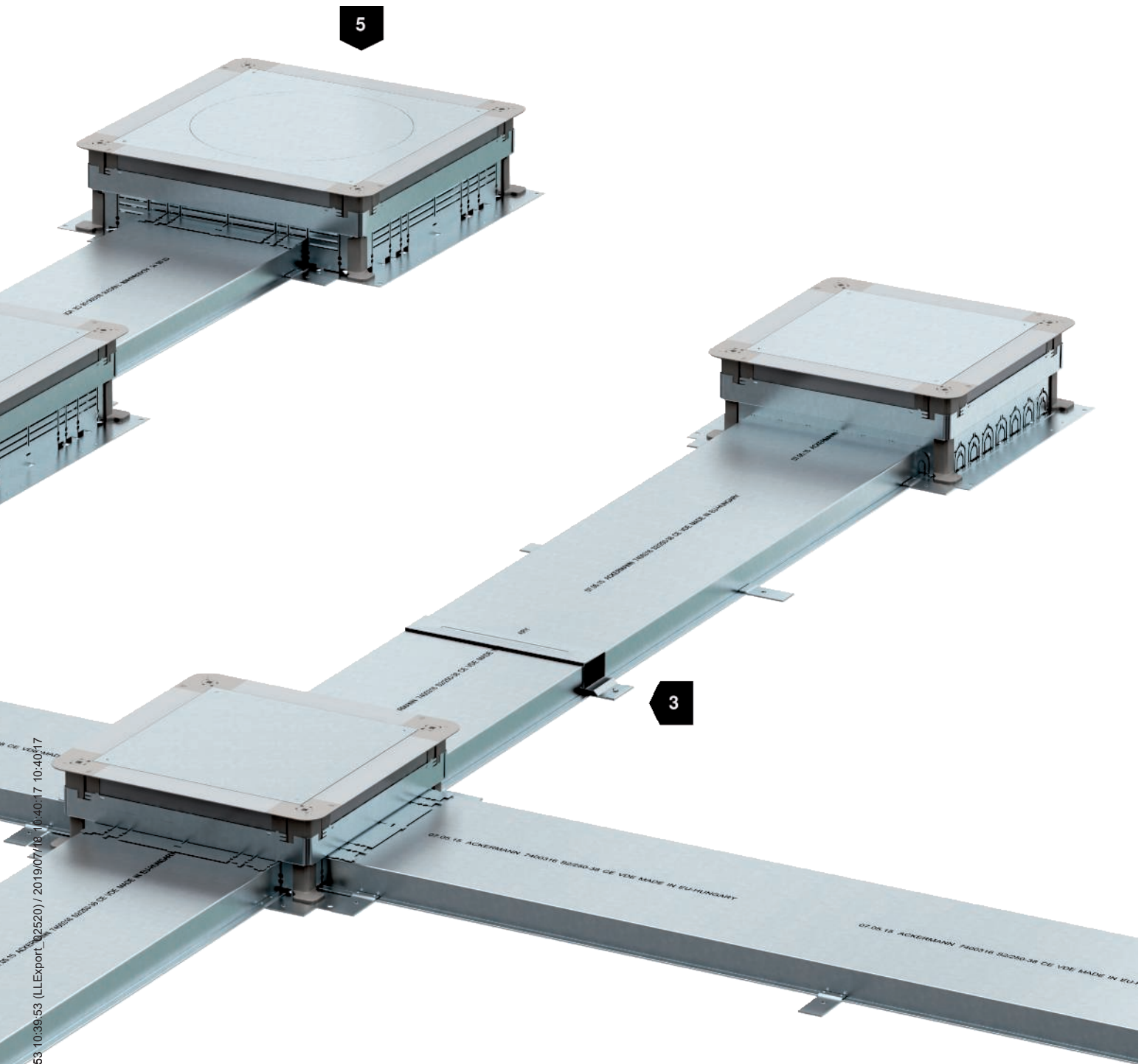

Screed thickness



Nominal screed thickness for EÜK screed-covered duct system

Avoiding crack formation

An important precondition for a proper underfloor installation is the screed structure. In the case of a screed-covered system, it is important that the screed thickness over the duct corresponds to the values in the standard, to avoid the formation of cracks.

Nominal screed thickness

The nominal screed thickness is dependent on the insulation layer, the individual load and the screed type. More detailed information for Germany can be found in DIN 18560.

Working of the screed



Working the screed

The excess height of the underfloor boxes must be completely surrounded with screed, in order to guarantee the stability of the boxes in the screed.

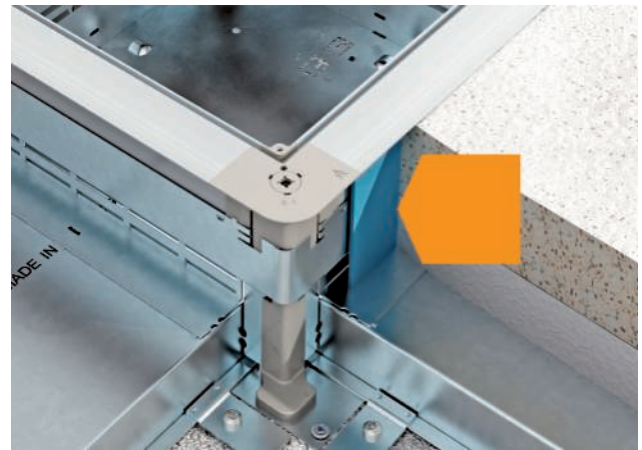

Use of a separating layer

When used in floating screed or in heated screeds on insulation layers, the box can be separated from the screed by a separating layer. The separating layer can be up to 3 mm thick and must reach to under the top frame of the box.

Floor types

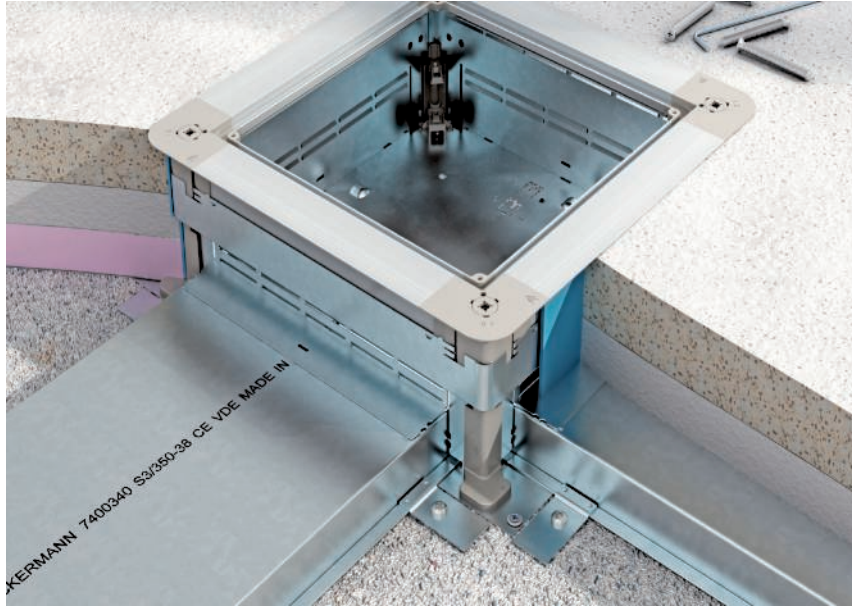

Application area

Floating screed

Underfloor installation ducts can be mounted in floating screed without complications. For noise reduction reasons, the ducts are laid inside the insulation.



Application area

Composite screed

In cement composite screed, the underfloor installation duct can be mounted quickly and easily. Additional protective measures are not required: The cement screed can be applied directly to the galvanized sheet steel duct.

Floating screed

When used in floating screeds, ensure that the duct system is sealed before the screed is applied.



Application area

Poured asphalt

Underfloor installation ducts can be used in a composite screed system made of floating poured asphalt. The installation temperature of the poured asphalt is around 250 °C. Bitumen corrugated card must be laid to provide protection to the ducts during pouring and the cooling phase of the poured asphalt. Cables are only installed after cooling.



Use in the field of

high loads

No insulation strips may be attached to the underfloor box. This ensures the maximum support area of the screed support frame. You can find system accessories, such as heavy-duty supports and heavy-duty mounting lids for the installation of cassettes of load classes SL1 and SL2, in the Heavy-Duty chapter of our catalogue.

Inclusion of EÜK duct system in the local equipotential bonding

We recommend including the EÜK screed-covered duct system in the equipotential bonding. The EÜK system offers the necessary connection options for protective conductors. All the system components are fully conductive.

The EMC regulations according to DIN EN 50174-2 (VDE 0800-174-2) require the inclusion of all the metallic system components up to the connection point as functional equipotential bonding.

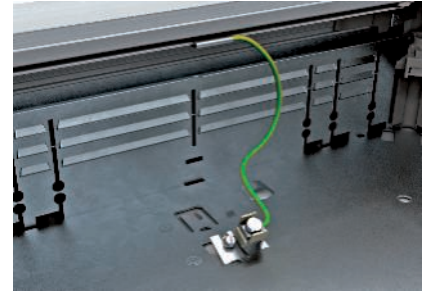
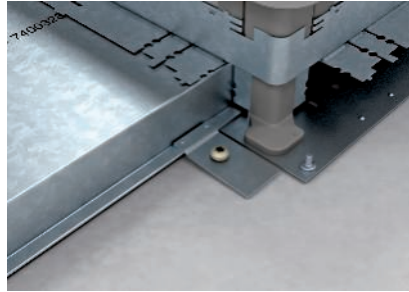
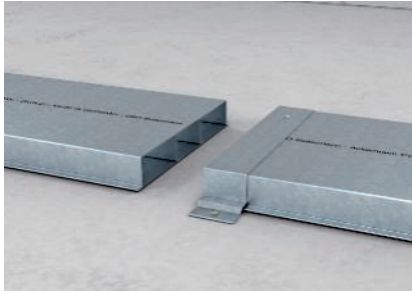

Mounting of connection shackle

Connection shackles create the conductive connection of the two inserted pieces of duct.

Earthing of the duct system

The VW E connection bracket for the conductive connection between the duct and underfloor box.

Earthing of the box top frame

If there is a fault, metallic parts will carry voltage. The protective conductor connection bracket 8AWR includes the underfloor boxes in the protective measures. Tighten the contact bolt with at least 1.2 Nm. Alternatively, conductive connections can be created between construction elements using external connections, by soldering, welding, riveting or screwing.

Height compensation of the underfloor box

The underfloor boxes of type UGD and UZD are available in three different height-adjustment ranges:

- 70–125 mm
- 115–170 mm
- 165–220 mm

Using height compensation construction kits (raising aids), it is also possible to convert the underfloor boxes to screed heights of up to 320 mm. System 55 is used for screed heights of 70 mm or less.

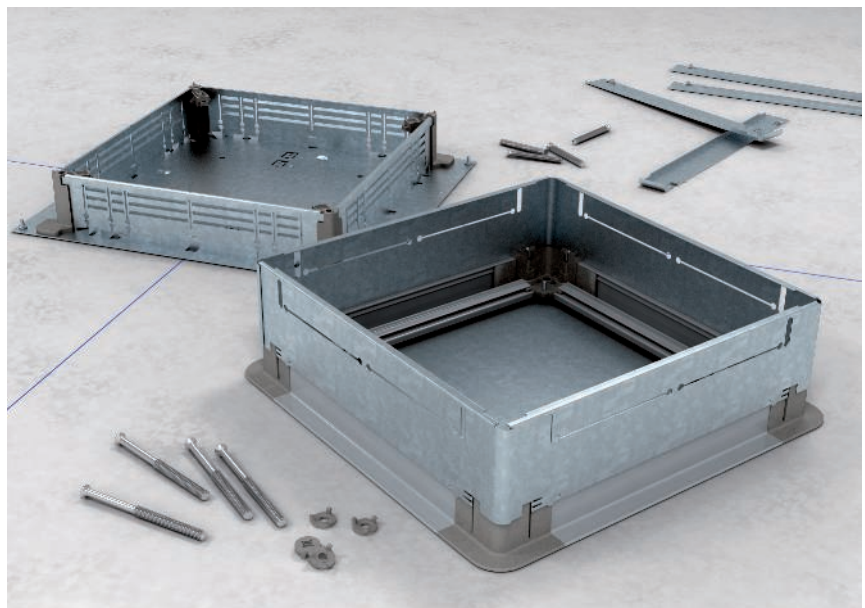

Fire protection



PYROSIT® NG fire protection foam

The PYROSIT® NG fire protection foam is a quick and simple type of cable insulation for use in underfloor ducts. If, during an electrical installation, underfloor ducts pass below walls classified for fire protection, then the ducts must be closed against smoke gas penetration and fire.

PYROSIT® NG is the ideal solution for use in screed-covered underfloor ducts: Mounting is carried out starting from the underfloor boxes on both sides of the wall. Empty plastic installation pipes, serving as a reserve for later retroinstallations, can also be foamed in.

Foam rubber fitting with fire protection additives

Fire resistance class	To EI120
Proof of application	European technical approval of the OIB, Vienna in conjunction with surveyor's report
Approval number	ETA-11/0527
Testing standard	EN 1366 Part 3
Min. insulation thickness	30 (2 x 15) cm
Max. duct size	35 x 5 cm
Min. screed thickness	3.5 cm
Spacing of the underfloor boxes	Unlimited

Maximum approved assignment of the opening area with installations: 60%. The data in the named proofs of use apply.

System benefits

- Applications covered by surveyor's comments
- Easy processing, even with brief interruptions
- Good substrate adhesion, even on metal ducts
- Foam volume per cartridge up to 2.1 litres
- Soft consistency – easy retroinstallation
- Empty pipes can also be foamed in as a reserve opening
- No surface coatings required
- Dust and fibre-free installation

Noise prevention and impact noise

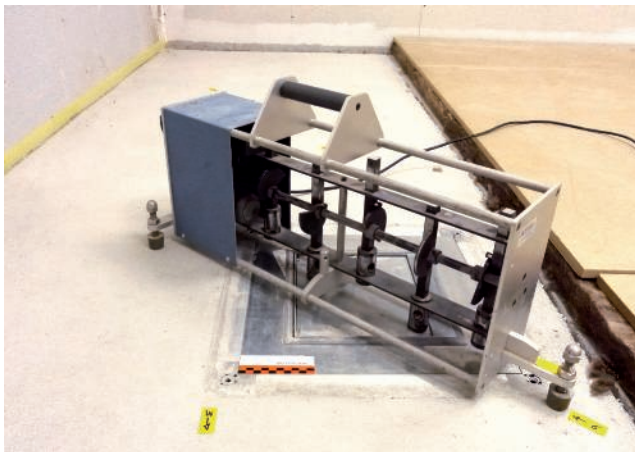

Minimum requirements

The minimum requirements for structural sound insulation are defined in DIN 4109 "Sound insulation in buildings". General information on the topic of sound insulation and the installation of underfloor systems can be found in the general planner section of the underfloor systems' catalogue. Qualified tests to determine the transmission of air and footfall sound were carried out together with the MÜLLER BBM GmbH testing institute in Planegg, Munich, for the EÜK duct system. The transmission of air and footfall sound was investigated for both vertical, i.e. from storey to storey, and horizontal sound transmission, i.e. from adjacent rooms. The test was carried out in a floating screed construction.

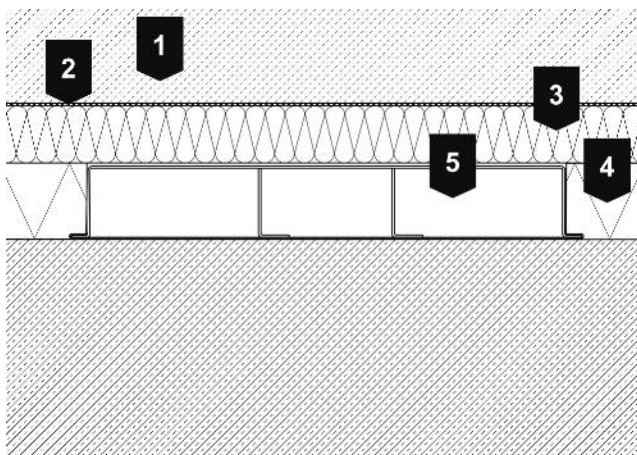

1	50 mm cement screed, CEMI 52.2 N, mass relative to area $m' = 15 \text{ kg/m}^2$
2	0.2 mm PE film
3	30 mm noise insulation damping, dynamic stiffness $s' = 15 \text{ MN/m}^3$
4	40 mm heat insulation, polystyrene EPS 100/035
5	38 mm installation trunking

Noise evaluation

With regard to the evaluated reduction of footfall sound of the screed without a floor system, statements made below can be considered as approved. The following recommendations for the OBO Bettermann underfloor systems relate to screed constructions which are spatially separated.

The required noise measures for the use of the type EÜK duct system in offices can be summarised as follows:

The EÜK system can run beneath floating screeds, through partitions with noise protection requirements, in accordance with Section 3. During measurement checking, it should be ensured that the connection sockets have a spacing of 2 m to the partition. This wall spacing of the floor socket should be maintained if there are sound requirements.

If the floor socket is closer to the partition, then there may be a reduction in noise insulation. However, this has not been investigated in detail. In the case of floor sockets close to the wall, it may be advisable to insert noise protection insulation in the trunking system, in order to exclude sound bypass transmission via the floor sockets.

Horizontal transmission of air and footfall sound

With horizontal transmission of footfall sound, the system is suitable for fulfilling the increased recommendations in the sense of Supplementary Sheet 2 of DIN 4109 [4], provided that the screed is separate in the area of the partition.

Vertical transmission of footfall sound

The EÜK floor system, including underfloor connection sockets, does not lead to a decrease of the required evaluated footfall sound reduction of a floating cement screed with regard to vertical transmission of footfall sound, should the underfloor boxes be decoupled.

Data taken from Report M88034/06 of 29th July 2014.

Underfloor boxes

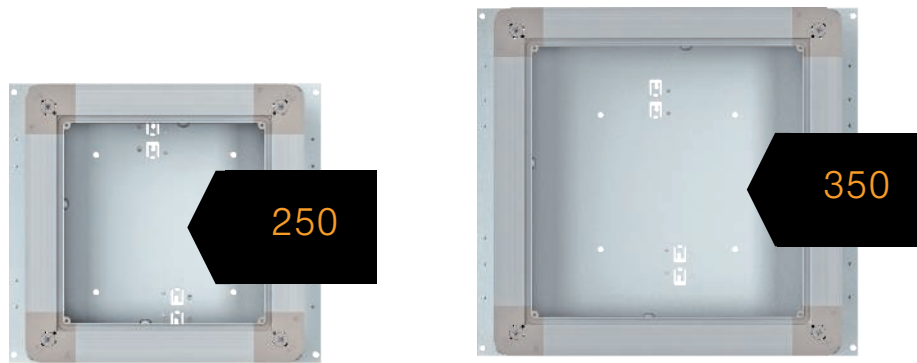

Function matrix, underfloor boxes, nominal size 250

Underfloor box	Insertable duct widths, nominal size	Height-adjustment range upper edge screed mm	Decouplable ¹	Suitable for SL application ²	Possible device installation, nominal sizes	Mounting lid in scope of supply
UZD 250-3	190, 250	70–125	Yes	Yes ³	2, 4, 6, 9, R4	No ⁴
UZD 115170 250-3	250	115–170	Yes	Yes	2, 4, 6, 9, R4	No ⁴
UZD 165220 250-3	250	165–220	Yes	Yes	2, 4, 6, 9, R4	No ⁴
UZD 250-3 R	Installation pipes	70–125	Yes	Yes ³	2, 4, 6, 9, R4	No ⁴
UGD 250-3 4	190, 250	70–125	Yes	Yes ³	4	Yes
UGD 250-3 6	190, 250	70–125	Yes	Yes ³	6	Yes
UGD 250-3 9	190, 250	70–125	Yes	Yes ³	9	Yes
UGD 250-3 R4	190, 250	70–125	Yes	Yes ³	R4	Yes

¹ Separate the screed contact frame from the box body. Not for SL application

² Application for areas with increased load requirements with separately available system accessories.

³ At lower screed heights, the floor construction must be agreed with technical planners.

⁴ Device installation units are installed in DUG blanking lids

Function matrix, underfloor boxes, nominal size 350

Underfloor box	Insertable duct widths, nominal size	Height-adjustment range upper edge screed mm	Decouplable ¹	Suitable for SL application ²	Possible device installation, nominal sizes	Mounting lid in scope of supply
UZD 350-3	190, 250, 350	70–125	Yes	Yes ³	4, 6, 9, R4, R7, R9	No ⁴
UZD 115170 350-3	250, 350	115–170	Yes	Yes	4, 6, 9, R4, R7, R9	No ⁴
UZD 165220 350-3	250, 350	165–220	Yes	Yes	4, 6, 9, R4, R7, R9	No ⁴
UZD 350-3 R	Installation pipes	70–125	Yes	Yes ³	4, 6, 9, R4, R7, R9	No ⁴
UGD 350-3 4	190, 250, 350	70–125	Yes	Yes ³	4	Yes
UGD 350-3 6	190, 250, 350	70–125	Yes	Yes ³	6	Yes
UGD 350-3 9	190, 250, 350	70–125	Yes	Yes ³	9	Yes
UGD 350-3 R4	190, 250, 350	70–125	Yes	Yes ³	R4	Yes
UGD 350-3 R7	190, 250, 350	70–125	Yes	Yes ³	R7	Yes
UGD 350-3 R9	190, 250, 350	70–125	Yes	Yes ³	R9	Yes

¹ Separate the screed contact frame from the box body. Not for SL application

² Application for areas with increased load requirements with separately available system accessories.

³ At lower screed heights, the floor construction must be agreed with technical planners.

⁴ Device installation units are installed in DUG blanking lids

Cable routing planning

Screed-covered ducts, 2-compartment

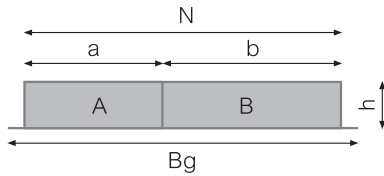

The following tables provide support when planning the cable routing in the underfloor trunking and show the recommended number of cables for each trunking type. The recommended number of cables takes a reserve of 50% in the trunking into account, in order to guarantee reinstallation of cables.

Duct type	S2 19028	S2 25028	S2 19038	S2 25038	S2 19048	S2 25048
Duct height h (mm)	28	28	38	38	48	48
Nominal width N (mm)	190	250	190	250	190	250
Total width Bg	210	270	210	270	210	270
Compartment width a (mm)	80	110	80	110	80	110
Compartment width b (mm)	110	140	110	140	110	140
Compartment A						
Cross-section A (mm ²)	2,028	2,808	2,808	3,888	3,588	4,688
Number of NYM ¹³ cables	10	14	14	19	18	23
Number of CAT ²³ cables	13	17	17	24	22	29
Compartment B						
Cross-section B (mm ²)	2,808	3,588	3,888	4,968	4,968	6,348
Number of NYM ¹³ cables	10	18	19	25	25	32
Number of CAT ²³ cables	17	22	24	30	30	39

¹ Heavy current cables NYM-J 3 x 2.5 mm, diameter = 10 mm, space requirement = 100 mm²

² CAT6 data cable, diameter = 9 mm, space requirement = 81 mm²

³ The calculation of the number of cables relates to an assignment of 50%, meaning that an appropriate reserve remains

Screed-covered ducts, 3-compartment

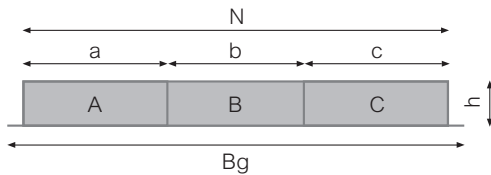

Duct type	S3 25028	S3 35028	S3 25038	S335038	S3 25048	S3 35048
Duct height h (mm)	28	28	38	38	48	48
Nominal width N (mm)	250	350	250	350	250	350
Total width Bg	270	370	270	370	270	370
Compartment width a (mm)	90	120	90	120	90	120
Compartment width b (mm)	70	110	70	110	70	110
Compartment width c (mm)	90	120	90	120	90	120
Compartment A						
Cross-section A (mm ²)	2,288	3,068	3,168	4,248	4,048	5,428
Number of NYM ¹³ cables	11	15	16	21	20	27
Number of CAT ²³ cables	14	19	19	26	25	33
Compartment B						
Cross-section B (mm ²)	1,794	2,834	2,484	3,924	3,174	5,014
Number of NYM ¹³ cables	9	14	12	19	16	25
Number of CAT ²³ cables	11	17	15	24	19	31
Compartment C						
Cross-section C (mm ²)	2,288	3,068	3,168	4,248	4,048	5,428
Number of NYM ¹³ cables	11	15	16	21	20	27
Number of CAT ²³ cables	14	19	19	26	26	33

¹ Heavy current cables NYM-J 3 x 2.5 mm, diameter = 10 mm, space requirement = 100 mm²

² CAT6 data cable, diameter = 9 mm, space requirement = 81 mm²

³ The calculation of the number of cables relates to an assignment of 50%, meaning that an appropriate reserve remains

Directional correction and sloping duct entries

The prepared duct openings of the underfloor boxes allow a slight change in direction or the sloping insertion of cables. The appropriate values can be found in the following tables.

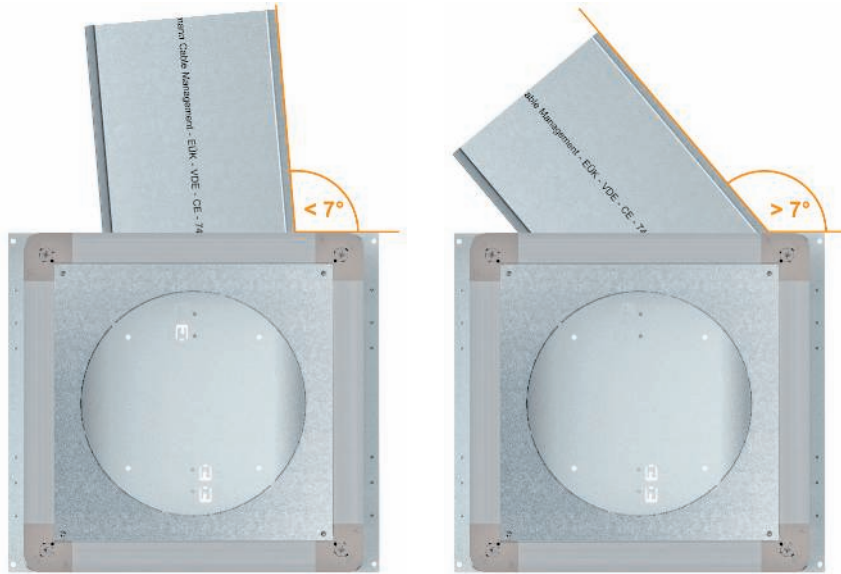

Duct directional corrections (RK)

Small duct direction corrections (up to 7°) can be compensated in the entry openings of the underfloor boxes with an adaptation cut.

Sloping duct entries (SE)

With appropriate adaptation cuts, sloping duct entries (> 7°) can be created according to the box side and entry opening.

Box size	Nominal size of duct insertion opening	Nominal duct size 190		Nominal duct size 250		Nominal duct size 350	
		RK bracket	SE bracket	RK bracket	SE bracket	RK bracket	SE bracket
250	190	7°	7°	-	-	-	-
	250	-	40°	7°	7°	-	-
350	190	7°	7°	-	-	-	-
	250	-	40°	7°	7°	-	-
	350	-	53°	-	42°	7°	7°

Standard data

To DIN EN 50085-1 and DIN EN 50085-2-2

Class		Underfloor ducts type S2 / S3	Underfloor boxes type UZD / UGD
6.2	According to impact resistance for installation and application		
6.2.7	Electrical installation duct systems for impact energy 20 J	20 J	20 J
6.3	According to temperatures, as specified in Tables 1, 2 and 3		
Table 1	Minimum storage and transport temperatures ± 2 °C	-25 °C	-25 °C
Table 2	Minimum installation and application temperatures ± 2 °C	+5 °C	+5 °C
Table 3	Application temperatures ± 2 °C	+60 °C	+60 °C
6.4	According to the resistance against fire spread		
6.4.2	Electrical installation duct systems which do not permit the spread of fire	x	x
6.5	According to the electrical conductivity		
6.5.1	Electrical installation duct systems with electrical conductivity	x	x
6.6	According to the electrical insulation property		
6.6.1	Electrical installation duct systems without electrical insulation capability	x	x
6.7	According to the protection ratings offered by the housing or casing to EN 60529:1991		
6.7.1	According to protection against ingress of solid foreign bodies	x	x
6.7.2	According to protection against ingress of water		
6.102	According to resistance to vertical loads affecting a small surface area		
6.102.2	Electrical installation duct systems for 750 N	x	
6.102.7	Electrical installation duct systems for 3,000 N		x
6.103	According to resistance to vertical loads affecting a large surface area		
6.103.3	Electrical installation duct systems for 5,000 N		x
6.103.5 ¹	Electrical installation duct systems for 15,000 N		x

¹ Test UZD with heavy-duty mounting lid DUG 250-3 4SL



Planning checklist

When planning a screed-covered underfloor system, the following points should be observed:

- ✓ Matching of the floor structure (screed height, screed type, insulation layers, sealing, etc.) with the architecture
- ✓ Observe the minimum installation depths of device installation units
- ✓ Matching the structural physics requirements (loads, impact sound, etc.)
- ✓ Select device installation units according to the floor cleaning method
- ✓ Specify the spacing between two underfloor boxes taking the tensile loading and occurring bend radii into account



Open trunking system, screed-flush OKA

The OKA open trunking system is a flexible system for in-screed cable routing. The trunking lids can also be opened along the whole length – even when installed with a floor covering. This means that the electrical installation in the trunking can be adapted at any time. Additional mounting benefits, such as lowerable floor covering profiles or rapid height-adjustment units, offer a great deal of flexibility and security for professional underfloor installations.



08_UFS / en / 2019/07/18 10:39:53 (LLE) / 2019/07/18 10:40:17 10:40:17

Matches any change

The OKA system offers a wide range of mounting options: The OKA-G trunking variant, with its flexible side walls, can be freely combined with the OKA-W trunking variant with its closed floor trough. The OKA system offers the right installation capacity for any installation requirements: The trunking is available in various widths and heights and there is also a large selection for device installation. Additional extension units also allow device installation, without reducing the usable cross-section in the trunking.

The trunking of the OKA system remains accessible at all times. The system is thus particularly suitable for areas in which there are regular modifications to the routed cables – such as offices, in which the workstations are not always in the same place. Depending on the devices used, the system can be employed with dry or wet-cleaned floor coverings.



Ideally suitable for large volumes of cables



Simple reinstallation and highest flexibility



Long-life thanks to robust construction

Two screed-flush solution variants – one principle

The screed-flush trunking of the OKA system is available in two versions – with a flexible side wall and with a closed floor trough. The two variants can be combined easily. The trunking is mounted directly on the raw concrete. In thin-layered screed, trunking installation for pure cable routing is possible from 40 mm. From a floor height plus floor covering of 55 mm, it is possible to install the service outlets of System 55.

The standard GES service outlet is available for a screed height of 70 mm or more. The height of the trunking system is adjusted to the top edge of the screed, thus offering a drip edge for the subsequent screed work. For this reason, during planning, the agreement of the screed height between units is particularly important.

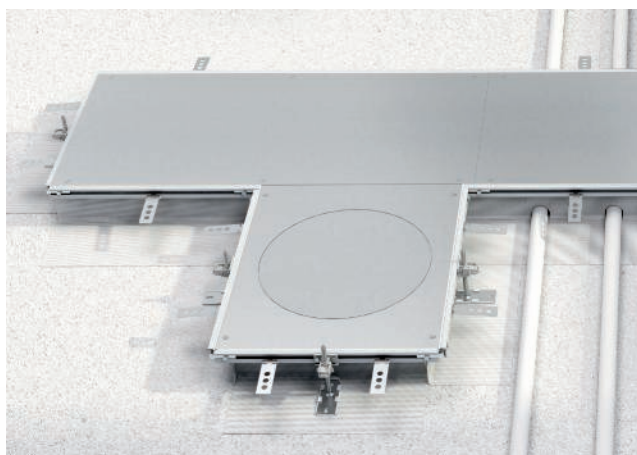

OKA-G – with flexible side wall

The variant possesses metal mesh side walls. During mounting, the side walls can be adapted easily to match the substrate and units crossing over. Should, for example pipelines cross the path of the trunking, they can be easily run through an opening in the mesh.



Height-adjustment range, OKA-G

If there are large evenness tolerances or if the screed height is unknown during renovation work, the OKA-G system can score on account of its large height-adjustment range: From 40 mm to 140 mm or from 40 mm to 240 mm.

Usable duct cross-sections

The tables in the Technical Section provide information on the usable cross-section of the OKA system. The height adjustment increases the trunking volume. If service outlets are used, then the usable cross-section is reduced accordingly.

OKA-W – with floor trough

Snap-in separating retainers allow structured, EMC-compatible cable routing: You can create up to three separate cable compartments. Thus, data and power cables can be routed separately.



Height-adjustment range, OKA-W

The OKA-W trunking is available in the height adjustment ranges 40 mm to 70 mm, 60 mm to 110 mm and 100 mm to 150 mm.

08_1/FS/en/2019/07/18 10:39:53 (LLExpert_02520)/2019/07/18 10:40:17 10:40:17

Reliability in practice

The OKA system has proved its worth in practice: It has already been installed in countless buildings. The product developers at OBO have used the practical experience gained to improve the system ever further.



Experts in the underfloor sector

The first OKA trunking system was presented in 1974 and, since then, has been continually adapted to installation practices. For more than four decades, planners, architects and customers have relied on the tried-and-trusted technology for creating a high level of flexibility in electrical installations. The system is beneficial, particularly in the field of large office spaces, as adjustments can be made at any time.



08_UFS / en / 2019/07/18 10:39:53 10:39:53 (LLExpert_02520) / 2019/07/18 10:40:17 10:40:17

Delivery as a ready-to-mount

The benefits of the OKA system can be seen directly when they are delivered to the construction site. The ready-for-mounting cable units are screwed together and their stable construction can withstand all the requirements of the construction site. The practical accessories simplify and accelerate the mounting of the system.

Trunking

The OKA trunking has a length of 2,400 mm and is available in the widths 200 mm, 300 mm, 400 mm, 500 mm and 600 mm.



Height-adjustment units with equipotential bonding

The supplied height-adjustment units allow simple height adjustment, fastening and conductive connection of the OKA trunking. The height adjustment takes place in two stages: Firstly, the height-adjustment units are roughly pre-adjusted to the given screed height using the integrated quick height-adjustment function and applied to the trunking units. In the second step, after fastening, the fine adjustment to the top edge of the screed is carried out using a screwdriver.

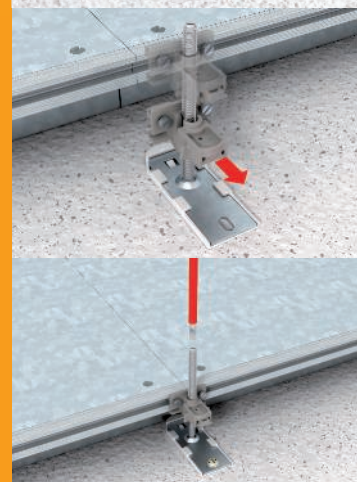

Extension units

Additional extension units also allow device installation, without reducing the usable cross-section in the trunking.



Pre-mounted units

The trunking units are supplied, ready to mount, with three covers. On delivery, the trunking lids are screwed on and surrounded. The scope of delivery contains six height-adjustment units and screed anchors, and, depending on the nominal trunking width, three lid butt seals or six lid butt supports.



Unlimited mounting options

From a screed height of 70 mm plus the floor covering, the various GES device installation units can be installed with central Modul 45 devices or standard devices. For screed heights above 55 mm, there are the screed-flush solutions of the System 55 range.

Loads

The OKA system stands out through its high load capacity. All the lids have metal thicknesses of 4 mm. Nominal trunking widths up to 300 mm are supplied with three lid butt seals, in order to ensure the maximum support for the mounting lid. From a trunking width of 400 mm, these struts are also equipped with height-adjustable supports. This avoids significant lid bending, even with large trunking widths.

Separating retainers

The separating retainers for the OKA-W trunking are locking and self-contacting. The separating retainers for the OKA-G trunking can be fastened individually in the concrete floor.



Lid variants

Two blanking lid variants are available for the trunking and the extension units: Locking and screwed-on. In addition, there are variants with openings for the installation of the service outlets GES4, GES6, GES9 and GESR9.



Connection to the screed

The screed anchor is hung in the aluminium side profile of the trunking. They create the connection between the trunking and the screed layer. To guarantee the most stable connection possible, no separating layer may be installed between the trunking and screed.

Easy to work

The OKA system can be worked easily before, during and after the screed work. In all the mounting steps, a series of intermeshed planning and agreement is decisive for correct installation. There is a wide selection of different device installation units, made of polyamide, stainless steel and aluminium for dry and wet-cleaned floors.

Protected against moisture

In addition to the normal lid butt seal, an optional flat foam rubber seal can be inserted. This ensures that, even in wet-cleaned floors, no moisture can enter the trunking system.



Varied floor coverings

The OKA system is suitable for all kinds of floor coverings: From carpets through to PVC or linoleum for wet-cleaned areas. The use of special cassettes also means that it can be used in parquet, laminate, tiled or stone floors.





Lowerable floor covering contact profile

The floor covering contact profile protects the adjacent cut floor covering edge. During screed laying, the edges are at first sunk. For working of the floor covering, they protrude above the trunking lid, marking the trunking system in the floor covering. At the same time, they form the guide edge for the floor covering.

Flexible equipment

The two trunking variants, OKA-W and OKA-G, are suitable for the installation of various service outlets. Depending on the furnishing plan and planned use, service outlets for the installation of six, nine or twelve Modul 45 individual devices can be selected. This corresponds to the installation of four, six or nine standard installation devices.

There is also a wide choice of materials and lid variants for the service outlets. In the round R9 system size, there is a version made from polyamide and die-cast aluminium. In addition, there is the die-cast aluminium GRAF9 service outlet for wet-cleaned floors. The rectangular services outlets are available in polyamide and stainless steel in the sizes GES4, GES6 and GES9. It is also possible to mount Telitanks – installation units protruding above the floor – in combination with the OKA system.

Service outlets*

OKA-G

The OKA-G trunking units with flexible side walls are available in two heights and four widths.

Heights: 40 mm to 140 mm, 40 mm to 240 mm.
Widths: 200 mm, 300 mm, 400 mm, 500 mm, 600 mm.

The trunking can be ordered with six different lid variants:

- Blanking lid, locking
- Blanking lid, screwed
- With installation opening for the square service outlet GES4
- With installation opening for the square service outlet GES6
- With installation opening for the square service outlet GES9
- With installation opening for the round service outlet GESR9





*You can find our complete product range in the product section of our underfloor systems catalogue.

OKA-W

The OKA-W trunking units with closed floor trough are available in three heights and four widths.

Heights: 40 mm to 70 mm (except for GES4 and GES6), 60 mm to 110 mm, 100 mm to 150 mm.
Widths: 200 mm, 300 mm, 400 mm, 500 mm, 600 mm.

The trunking can be ordered with six different lid variants:

- Blanking lid, locking
- Blanking lid, screwed
- With installation opening for the square service outlet GES4
- With installation opening for the square service outlet GES6
- With installation opening for the square service outlet GES9
- With installation opening for the round service outlet GESR9



Installation principle, OKA screed-flush trunking system

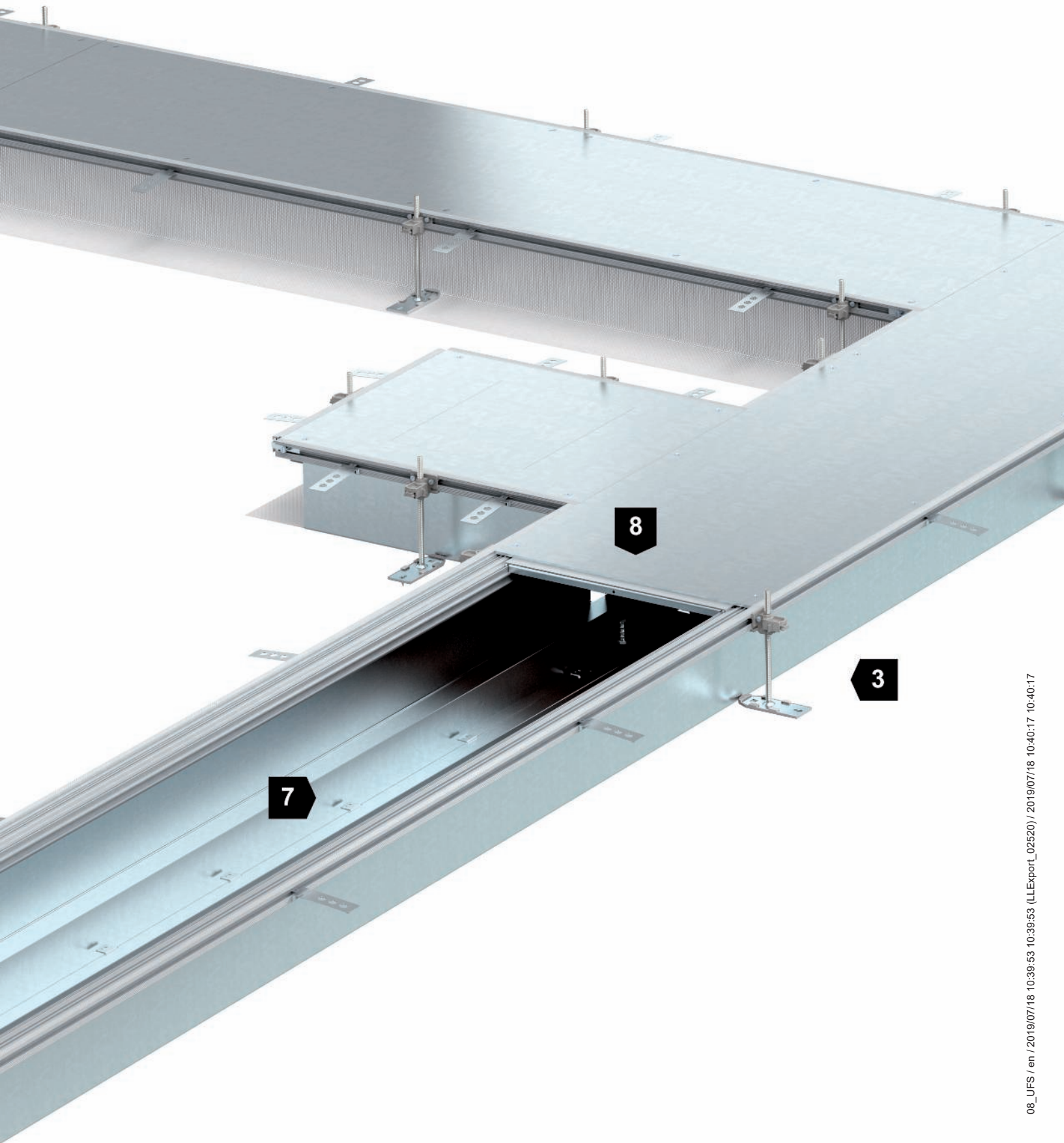

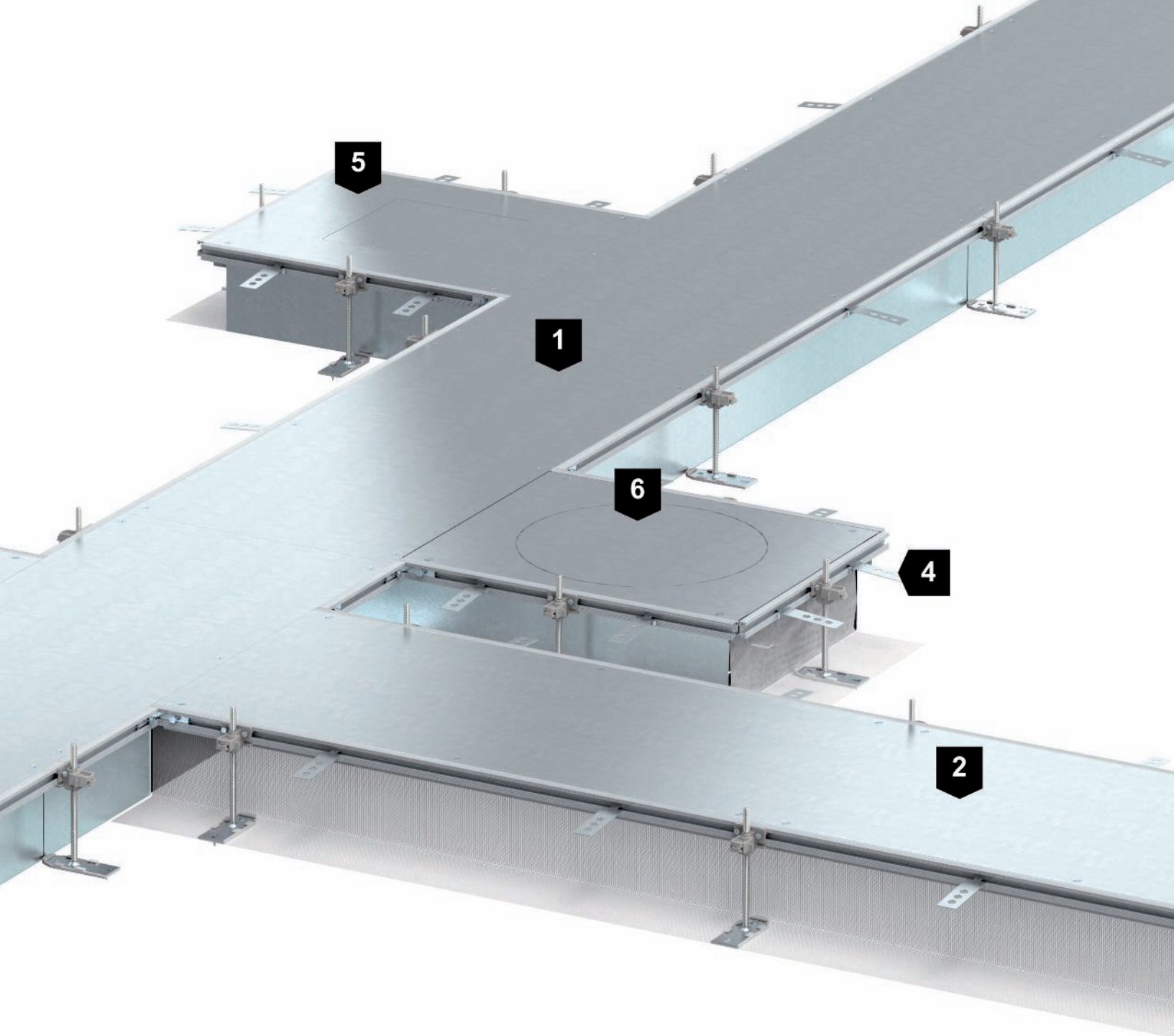

1	OKA-W installation trunking
2	OKA-G installation trunking
3	Height-adjustment unit
4	Screed anchor
5	OKA-W extension unit with blank, closed mounting opening
6	OKA-G extension unit with blank, closed mounting opening
7	Separating retainer
8	Lid butt support

Screed and floor covering contact profiles



Application of the screed

When laying the screed, the side profiles of the trunking must be fully supported with screed. Loads may not be placed on the trunking until the screed has hardened. Impurities through the screed mortar should be avoided or removed later.

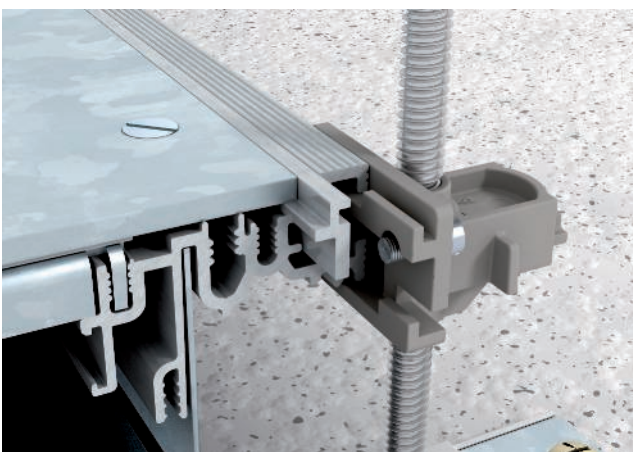

Lowering a floor covering contact profile

Floor covering contact profiles are used to protect the neighbouring floor covering cutting edges. In the as-delivered state, these profiles are flush, to allow finishing of the screed.

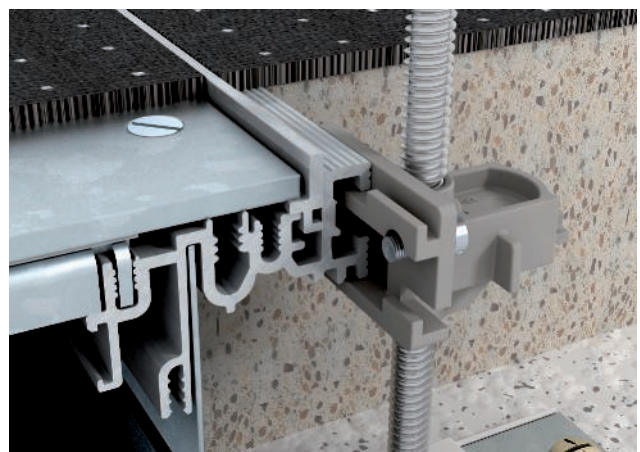

Using a floor covering contact profile

If the floor covering contact profile is required, then it can simply be mounted in the opposite direction. The profile is designed in such a way as to ensure the required lid play in the finished state.

Moisture protection and equipotential bonding

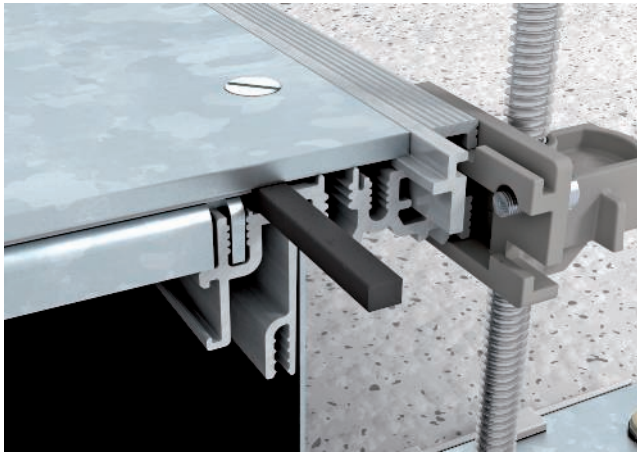

Insert moisture protection

The use of OKAFD seal together with the OKARK... insertion cassettes permits the use of the OKA-G and OKA-W trunking systems for wet-cleaned hard floors. The OKAFD seal is inserted into the aluminium profile in the lengthwise direction at the position indicated.

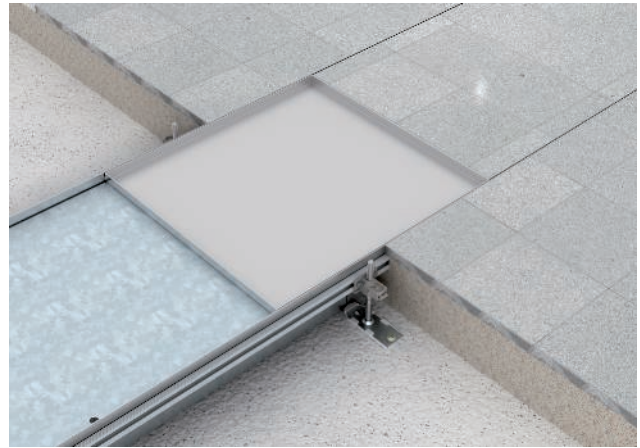

Use of cassettes

When used in wet-cleaned floors, there is the option of equipping the trunking system with cassettes.

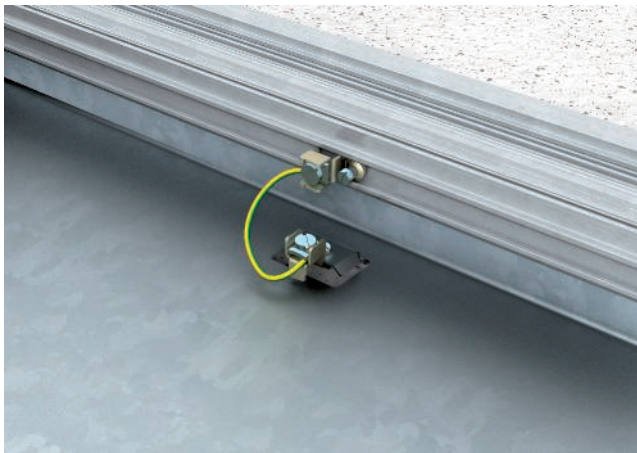

Create equipotential bonding

We recommend including the OKA screed-flush trunking system in the equipotential bonding. The OKA system offers the required connection options for protective conductors, as well as the continuous conductivity of all the system components via the height-adjustment units. The EMC regulations according to DIN EN 50174-2 (VDE 0800-174-2) require the inclusion of all the metallic system components up to the connection point as functional equipotential bonding.

Cable routing planning in the OKA-W

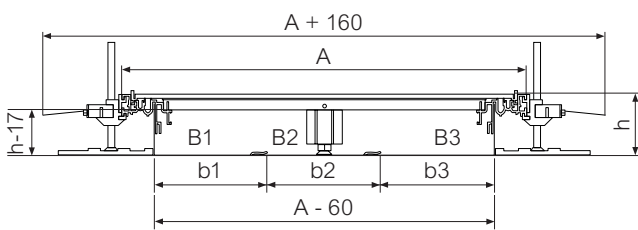

The following tables provide support when planning the cable routing in the OKA trunking system and show the recommended number of cables for each trunking type. The recommended number of cables takes a reserve of 50% in the trunking into account, in order to guarantee retroinstallation of cables.

The adjustment of the height of the OKA trunking increases the usable trunking cross-section. If service outlets are installed in the trunking section, then the usable cross-section is reduced. (See appropriate table)

Trunking cross-section and assignment OKA-W

Trunking type	OKA-W 200	OKA-W 200	OKA-W 200	OKA-W 300	OKA-W 300	OKA-W 300
System size A	200	200	200	300	300	300
System height h (mm)	40	60	100	40	60	100
Compartments	2	2	2	3	3	3
Internal trunking dimension A-68 (mm)	132	132	132	232	232	232
Usable trunking height H-17 (mm)	23	43	83	23	43	83
Total usable cross-section Bges (mm ²)	2,450	5,452	10,258	3,980	8,604	17,050
Compartment width b1 (mm)	66	66	66	77	77	77
Compartment width b2 (mm)	66	66	66	77	77	77
Compartment width b3 (mm)	-	-	-	77	77	77
Compartment 1						
Cross-section B1 (mm ²)	1,300	2,764	5,166	1,436	2,955	5,997
Number of NYM ¹³ cables	7	14	26	7	15	30
Number of CAT ²³ cables	8	17	32	9	18	37
Compartment 2						
Cross-section B2 (mm ²)	1,150	2,688	5,092	1,150	2,688	5,092
Number of NYM ¹³ cables	6	7	13	3	7	13
Number of CAT ²³ cables	7	8	16	4	8	16
Compartment 3						
Cross-section B3 (mm ²)	-	-	-	1,394	2,961	5,961
Number of NYM ¹³ cables	-	-	-	14	15	30
Number of CAT ²³ cables	-	-	-	17	18	37

¹ Heavy current cables NYM-J 3 x 2.5 mm, diameter = 10 mm, space requirement = 100 mm²,

² Data cable CAT6, diameter = 9 mm, space requirement = 81 mm²

³ The stated number of cables refers to an assignment of 50%, meaning that an appropriate reserve remains

Trunking cross-section and assignment OKA-W

Trunking type	OKA-W 400	OKA-W 400	OKA-W 400	OKA-W 500	OKA-W 500	OKA-W 500
System size A	400	400	400	500	500	500
System height h (mm)	40	60	100	40	60	100
Compartments	3	3	3	3	3	3
Internal trunking dimension A-68 (mm)	332	332	332	432	432	432
Usable trunking height H-17 (mm)	23	43	83	23	43	83
Total usable cross-section Bges (mm ²)	6,086	11,897	24,250	8,331	16,097	32,413
Compartment width b1 (mm)	111	111	111	144	144	144
Compartment width b2 (mm)	111	111	111	144	144	144
Compartment width b3 (mm)	111	111	111	144	144	144
Compartment 1						
Cross-section B1 (mm ²)	2,197	4,366	8,746	2,952	5,773	11,497
Number of NYM ¹³ cables	11	22	44	15	29	58
Number of CAT ²³ cables	14	27	54	18	36	71
Compartment 2						
Cross-section B2 (mm ²)	1,824	3,267	6,903	2,567	4,674	9,608
Number of NYM ¹³ cables	9	12	35	13	24	48
Number of CAT ²³ cables	12	20	43	16	29	60
Compartment 3						
Cross-section B3 (mm ²)	2,065	4,264	8,601	2,812	5,650	11,308
Number of NYM ¹³ cables	21	43	86	28	57	113
Number of CAT ²³ cables	25	53	106	35	70	140

¹ Heavy current cables NYM-J 3 x 2.5 mm, diameter = 10 mm, space requirement = 100 mm²,

² Data cable CAT6, diameter = 9 mm, space requirement = 81 mm²

³ The stated number of cables refers to an assignment of 50%, meaning that an appropriate reserve remains

Trunking type	OKA-W 600	OKA-W 600	OKA-W 600
System size A	600	600	600
System height h (mm)	40	60	100
Compartments	3	3	3
Internal trunking dimension A-68 (mm)	532	532	532
Usable trunking height H-17 (mm)	23	43	83
Total usable cross-section Bges (mm ²)	10,589	20,291	40,602
Compartment width b1 (mm)	177	177	177
Compartment width b2 (mm)	177	177	177
Compartment width b3 (mm)	177	177	177
Compartment 1			
Compartment volume B1 (mm ²)	3,693	7,159	14,199
Number of NYM ¹³ cables	19	36	71
Number of CAT ²³ cables	23	44	88
Compartment 2			
Compartment volume B2 (mm ²)	3,342	6,102	12,396
Number of NYM ¹³ cables	17	31	62
Number of CAT ²³ cables	21	38	77
Compartment 3			
Compartment volume B3 (mm ²)	3,554	7,030	14,007
Number of NYM ¹³ cables	36	70	140
Number of CAT ²³ cables	44	87	173

¹ Heavy current cables NYM-J 3 x 2.5 mm, diameter = 10 mm, space requirement = 100 mm²,

² Data cable CAT6, diameter = 9 mm, space requirement = 81 mm²

³ The stated number of cables refers to an assignment of 50%, meaning that an appropriate reserve remains

Cable routing planning in the OKA-G

The following tables provide support when planning the cable routing in the OKA trunking system and show the recommended number of cables for each trunking type. The recommended number of cables takes a reserve of 50% in the trunking into account, in order to guarantee retroinstallation of cables.

The adjustment of the height of the OKA trunking increases the usable trunking cross-section. If service outlets are installed in the trunking section, then the usable cross-section is reduced. (See appropriate table)

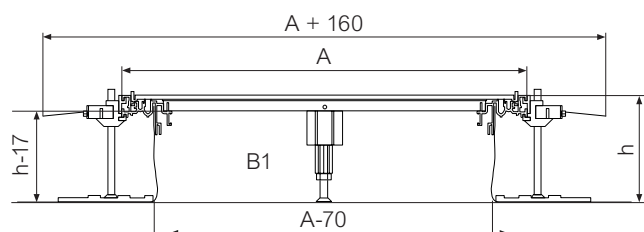

Trunking cross-section and assignment OKA-G

Trunking type	OKA-G 200	OKA-G 200	OKA-G 200	OKA-G 300	OKA-G 300	OKA-G 300
System size A	200	200	200	300	300	300
System height h (mm)	40	140	240	40	140	240
Internal trunking dimension A-70 (mm)	130	130	130	230	230	230
Usable trunking height H-17 (mm)	23	123	223	23	123	223
Cross-section B1 (mm ²)	2,700	15,900	29,100	5,050	28,250	51,450
Number of NYM ¹³ cables	14	80	146	26	142	258
Number of CAT ²³ cables	17	98	180	31	175	318

Trunking type	OKA-G 400	OKA-G 400	OKA-G 400	OKA-G 500	OKA-G 500	OKA-G 500
System size A	400	400	400	500	500	500
System height h (mm)	40	140	240	40	140	240
Internal trunking dimension A-70 (mm)	330	330	330	430	430	430
Usable duct height H-17 (mm)	23	123	223	23	123	223
Cross-section B1 (mm ²)	6,740	37,578	68,778	9,090	49,928	91,128
Number of NYM ¹³ cables	34	188	344	46	250	456
Number of CAT ²³ cables	42	232	425	56	308	564

Trunking type	OKA-G 600	OKA-G 600	OKA-G 600
System size A	600	600	600
System height h (mm)	40	140	240
Internal trunking dimension A-70 (mm)	530	530	530
Usable trunking height H-17 (mm)	23	123	223
Cross-section B1 (mm ²)	11,440	62,278	113,478
Number of NYM ¹³ cables	57	312	568
Number of CAT ²³ cables	71	385	701

¹ Heavy current cables NYM-J 3 x 2.5 mm, diameter = 10 mm, space requirement = 100 mm²,

² Data cable CAT6, diameter = 9 mm, space requirement = 81 mm²

³ The stated number of cables refers to an assignment of 50%, meaning that an appropriate reserve remains

Reduction of the trunking cross-section



Reduction of the trunking cross-section through the installation of a service outlet in mm²

Service outlet type	Installation direction transverse to trunking course	Installation direction parallel to trunking course
GES4-2	11,000	11,000
GES6-2	14,238	11,243
GES9-2	13,673	13,673
GESR9-2	18,240	18,240
GESR9/10	23,935	24,960
GRAF9-2	19,608	19,608
GES9/55UV*	9,559	9,167
GESR9/55UV*	11,225	11,225
GRAF9-2 with MT45V0*	14,744	14,744

* Special systems for low screed heights

Fire protection



PYROPLUG® Block foam block

The OBO PYROPLUG® Block 200 cable insulation is the ideal cable insulation for use in underfloor trunking. If, during an electrical installation, underfloor trunking passes below walls classified for fire protection, then the trunking must be closed against smoke gas penetration and fire. With the OKA system, the trunking lids are removed on both sides of the wall and the PYROPLUG® blocks inserted from both sides. Retroinstallations can be carried out very easily by removing individual blocks.

System benefits

- Mounting directly in underfloor trunking
- Cable insulation invisible on outside
- Mounting of empty pipes to prepare for retroinstallations
- Dust and fibre-free mounting
- Residual joints closed with PYROPLUG® screed filler (type FBA-SP)

Foam rubber fitting with fire protection additives

Fire resistance class	S90
Proof of application	General construction approval of DIBt, Berlin in conjunction with surveyor's report
Approval number	Z-19.15-1849
Testing standard	DIN 4102 Part 9
Min. insulation thickness	20 mm
Max. trunking size	60 x 16 mm

Footfall sound



Minimum requirements

The minimum requirements for structural sound insulation are defined in DIN 4109 "Sound insulation in buildings". General information on the topic of sound insulation and the installation of underfloor systems can be found in the general planner section of the catalogue.

Qualified tests to determine the transmission of air and footfall sound were carried out together with the MÜLLER BBM GmbH testing institute in Planegg, Munich, for the OKA trunking system. The transmission of air and footfall sound was investigated for both vertical, i.e. from storey to storey, and horizontal sound transmission, i.e. from adjacent rooms.

The test was carried out in a floating screed construction.

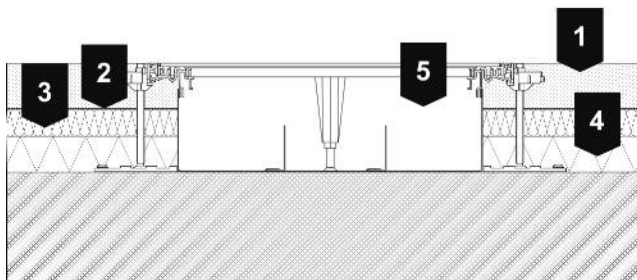

1	50 mm cement screed, CEMI 52.2 N, mass relative to area $m' = 15 \text{ kg/m}^2$
2	0.2 mm PE film
3	30 mm noise insulation damping, dynamic stiffness $s' = 15 \text{ MN/m}^3$
4	40 mm heat insulation, polystyrene EPS 100/035
5	38 mm installation trunking

Noise evaluation

The following section evaluates the test results. With regard to the evaluated reduction of footfall sound of the screed without a floor system, statements made below can be considered as approved.

The noise evaluation, based on the available test certificates, can be summarised as follows:

Horizontal transmission of air and footfall sound: The system is suitable for construction situations with partition requirements up to $R'w = 52 \text{ dB}$.

With horizontal transmission of footfall sound, the system fulfils the normal recommendations in the sense of Supplementary Sheet 2 of DIN 4109 [4]. Should there be requirements for increase footfall sound protection, then noise protection insulation should be added to the system in the area of the partition. Rock-wool or polyester fibre materials can be used as noise protection insulation and should be inserted in the installation trunking to a length of at least 30 cm.

Vertical transmission of footfall sound: The OKA-W system (open trunking system, screed-flush) reduces the evaluated footfall sound reduction in comparison with an unaffected floor structure of a vertical screed in the vertical transmission direction by $\Delta Lw = 5 \text{ dB}$.

Data taken from Report M88034/06 of 29 July 2014.

Standard data

To DIN EN 50085-1 and DIN EN 50085-2-2

Class		Trunking systems OKA-W / OKA-G
6.2	According to impact resistance for installation and application	
6.2.5	Electrical installation trunking systems for impact energy 20 J	20 J
6.3	According to temperatures, as specified in Tables 1, 2 and 3	
Table 1	Minimum storage and transport temperature ± 2 °C	-25 °C
Table 2	Minimum installation and application temperatures ± 2 °C	+5 °C
Table 3	Application temperatures ± 2 °C	+60 °C
6.4	According to the resistance against fire spread	
6.4.2	Electrical installation trunking systems which do not permit the spread of fire	x
6.5	According to the electrical conductivity	
6.5.1	Electrical installation duct systems with electrical conductivity	x
6.6	According to the electrical insulation property	
6.6.1	Electrical installation trunking systems without electrical insulation capability	x
6.7	According to the protection ratings offered by the housing or casing to EN 60529:1991	
6.7.1	According to protection against ingress of solid foreign bodies	x
6.7.2	According to protection against ingress of water	
6.102	According to resistance to vertical loads affecting a small surface area	
6.102.7	Electrical installation trunking systems for 3,000 N	x
6.103	According to resistance to vertical loads affecting a large surface area	Not tested



Planning checklist

When planning a screed-flush underfloor system, the following points should be observed:

- ✓ Matching of the floor structure (screed height, screed type, insulation layers, sealing, etc.) with the architecture
- ✓ Observe the minimum installation depths of device installation units
- ✓ Matching the structural physics requirements (loads, impact sound, etc.)
- ✓ Select device installation units according to the floor cleaning method
- ✓ When selecting the nominal trunking sizes take sufficient assignment reserves into account



OKB brush bar trunking system

There are almost no signs of how this room is supplied with power. Only a slender, discreet brush bar along the wall offers an indication. It is there that the open, screed-flush OKB brush bar trunking system from Ackermann made by OBO runs. The special feature:

The trunking has an opening towards the wall along its entire length. A brush bar covers this opening and serves as visually attractive sight and dust protection. The cables can be run out of the trunking at any location.



09_UFS_en / 2019/06/18-10:39:53 0-39:53 (LLEExport_0-320) / 2019/07/18 10:40:17 10:40:17

Perfectly adjusted

The OKB brush bar trunking system remains flexible, from the first planning step through to later use. It can be adapted to the appropriate room situation at any time: The mounted trunking can be opened easily and re-equipped.

The system offers discreet access to power and data cables – no matter whether in high-quality private housing, in offices or in exhibition areas. The combination with additional OBO products is very simple: Installation pipes can be used to connect floor sockets (GES R2 or UDHOME) with the trunking system. Use with other trunking systems to supply the area is also possible.



ACKERMANN
MADE BY OBO



Flexible system in the screed

The OKB system runs directly on the wall or along floor-height windows. The system is mounted directly on the raw concrete before the screed work. Alternatively, it can be installed in a prepared opening in the screed.

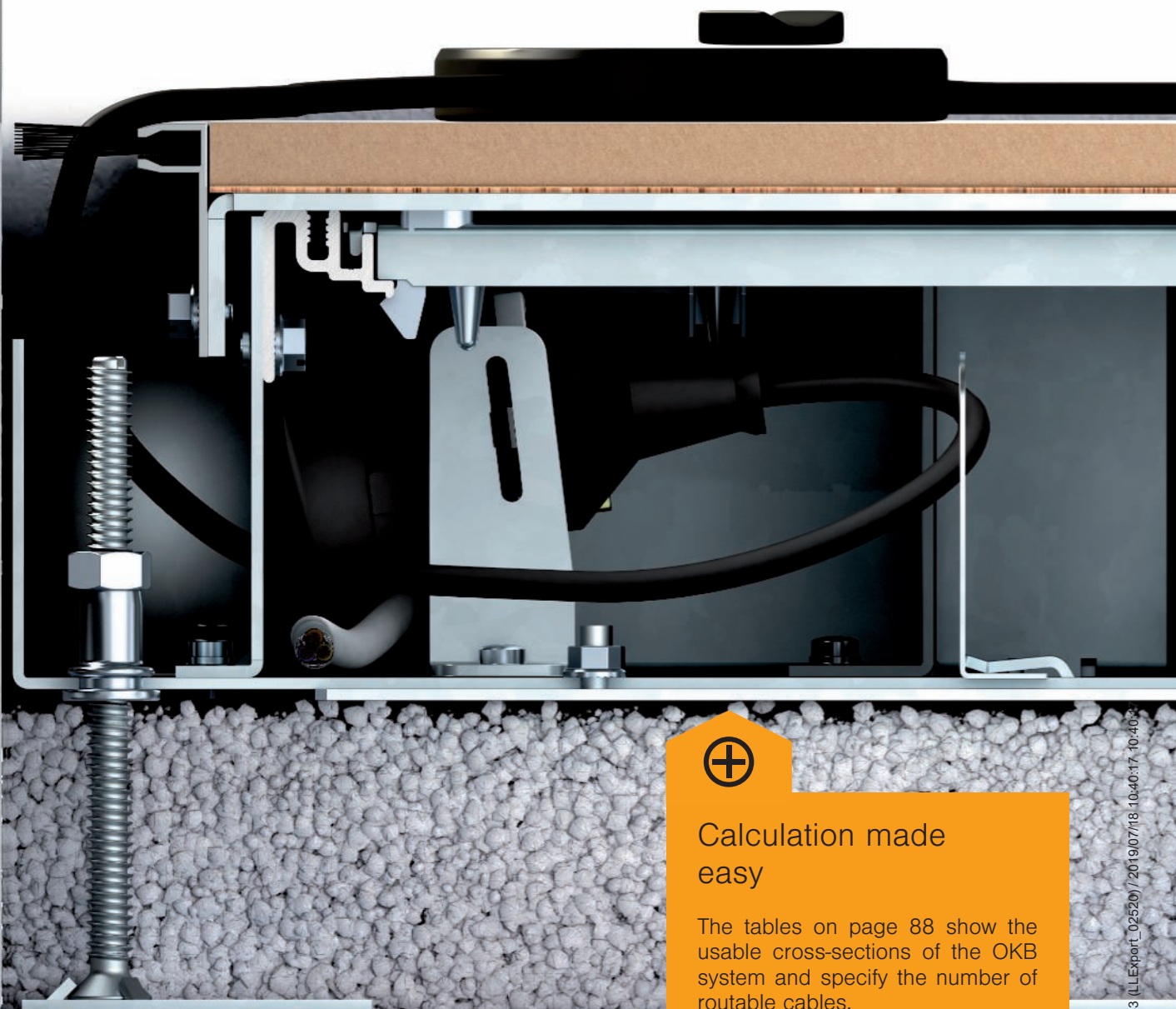

Calculation made easy

The tables on page 88 show the usable cross-sections of the OKB system and specify the number of routable cables.

08_UFS / en / 2019/07/18-10:39:53 (LLE:part_02520) / 2019/07/18-10:40:17-10:40:23

The right cross-section

The 250 mm-wide trunking is separated into two compartments by means of a partition. Thus, data and power cables can be routed separately. The first trunking compartment offers a usable cross-section of 4,231 mm² for cable routing. The second trunking compartment has a usable cross-section of 7,306 mm². The installation of universal supports reduces the free cross-section in the trunking.

Floor structure height

The minimum floor structure height of the OKB system is 93 mm. The trunking system can be adjusted, exact to the millimetre, to the top edge of the screed using the separately available height-adjustment units.



Mounting before screed work

The OKB system is mounted on the raw concrete before the screed work. It runs along the walls for the entire length of the room. The trunking can be adjusted to the appropriate room shape using the matching internal and external corners. The system can be adjusted exactly to the planned screed height using the height-adjustment feet.



Before mounting

Firstly, the height-adjustments units are screwed into the trunking. Then, the trunking bases are mounted using the supplied connectors. The connectors ensure a secure, conductive connection.

In every angle

The practical fittings of the OKB system allow routing into any corner of the room. Appropriate internal and external corners ensure uncomplicated mounting.



The right level

The height of the trunking can be adjusted using height-adjustment screws on the top edge of the screed and then secured at this height using lock nuts. In the next step, the floor plates of the height-adjustment units are fastened to the raw ceiling.



Ideal integration in the screed

The open brush bar trunking offers a range of solutions for optimum integration in the screed: Protection brackets for the brush bar, insertion openings for pipe insertion and a screed contact edge for screed-flush installation.

The trunking system must be masked completely during the screed work and not walked upon.

Protective angle for expansion

During screed laying, the appropriate brackets ensure protection of the brush bar. The brackets are contained in the scope of delivery.



Insertion openings

If additional connections are planned in the room – for example with a UDHOME floor socket, then the system can be connected easily. Simple use the break-out openings to insert pipes and connect the flexible electrical installation pipes.

Screed contact edge

The screed side of the trunking possesses a support plate for the screed. The screed is compacted under the support to increase stability. This screed contact edge serves as a drip edge for the screed layer, thus allowing screed-flush installation. It is possible to route a 3 to 5 mm thick insulation strip on the side wall of the trunking.

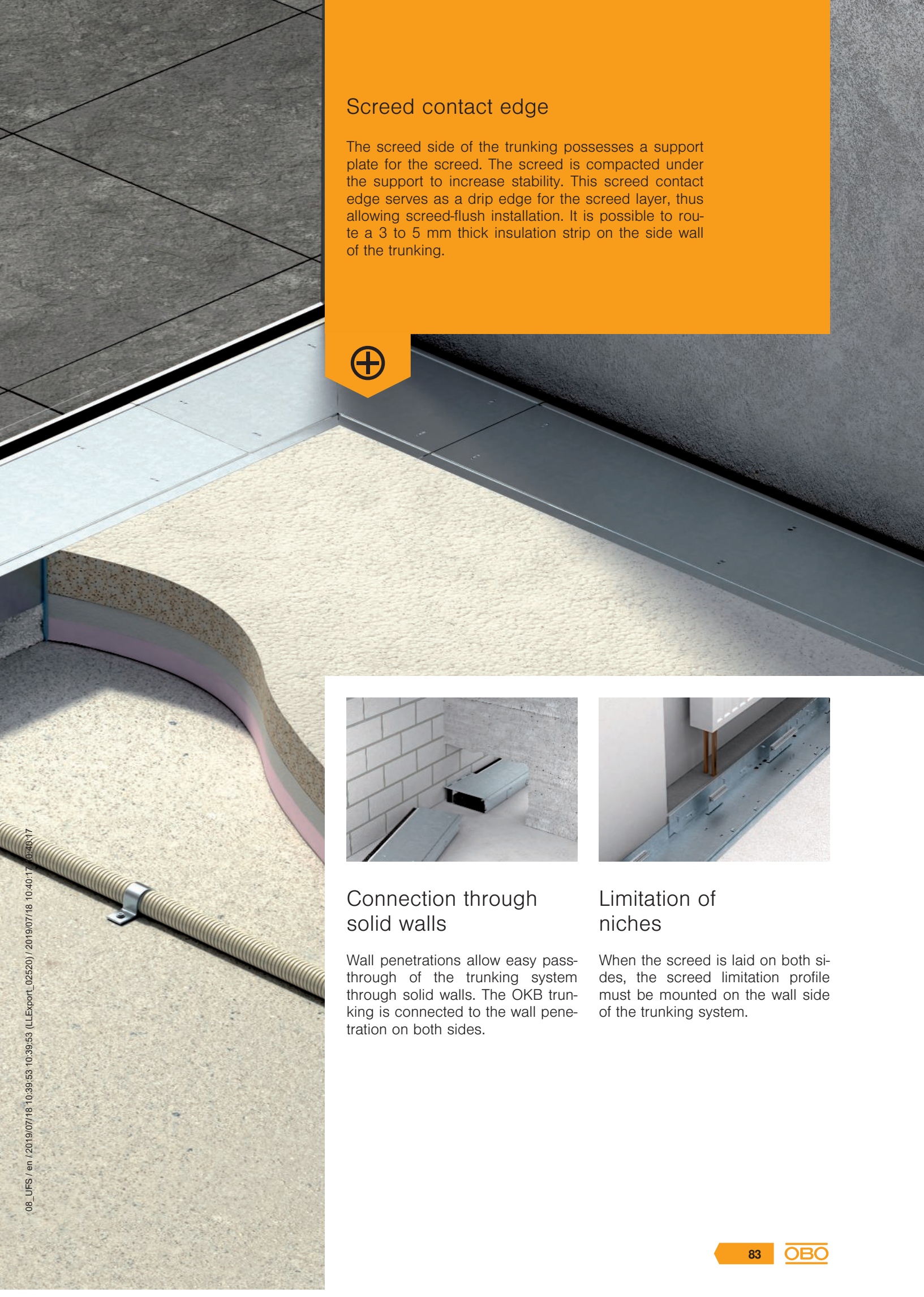

Connection through solid walls

Wall penetrations allow easy pass-through of the trunking system through solid walls. The OKB trunking is connected to the wall penetration on both sides.



Limitation of niches

When the screed is laid on both sides, the screed limitation profile must be mounted on the wall side of the trunking system.

Last installation steps

After screed laying, the trunking can be equipped with sockets or data modules, according to the user's requirements.

Fine adjustment also takes place now: The floor covering contact edge and the brush bars are adjusted to match the top edge of the floor covering. This creates a perfectly matched trunking system, which is barely visible.



Blanking lid

If no cable outlet is required, blanking lids can be installed without a brush bar.



Adjusting the floor height

Using screws in the side profile, it is possible to adjust the floor covering contact edge of the trunking to the height of the top edge of the finished floor in an adjustment range of 25 mm.



Covering the lid

All the lids of the OKB system are covered with the selected finished floor after mounting. Matched to the height of the covering, the brush bar can be adjusted exactly to the top edge of the floor covering in a range of 25 mm.



Device installation

Devices can be installed in the trunking in two ways: Either using conventional wiring or using the toolless, screwless installation using devices of the Modul 45connect series.

The plug connections and the prefabricated connection cables of the Modul 45connect sockets simplify and accelerate mounting. This means that later refitting in the system is not a problem: Only the plug connections must be released and the mounting box reequipped.

Sockets, data and multimedia connections can be installed with the connection direction to the wall or the room.



Installation principle, OKB

1	External corner
2	Connector for trunking unit
3	Supply trunking
4	Trunking unit with brush bar
5	Lid butt seal
6	Internal corner
7	Height-adjustment unit
8	Wall penetration

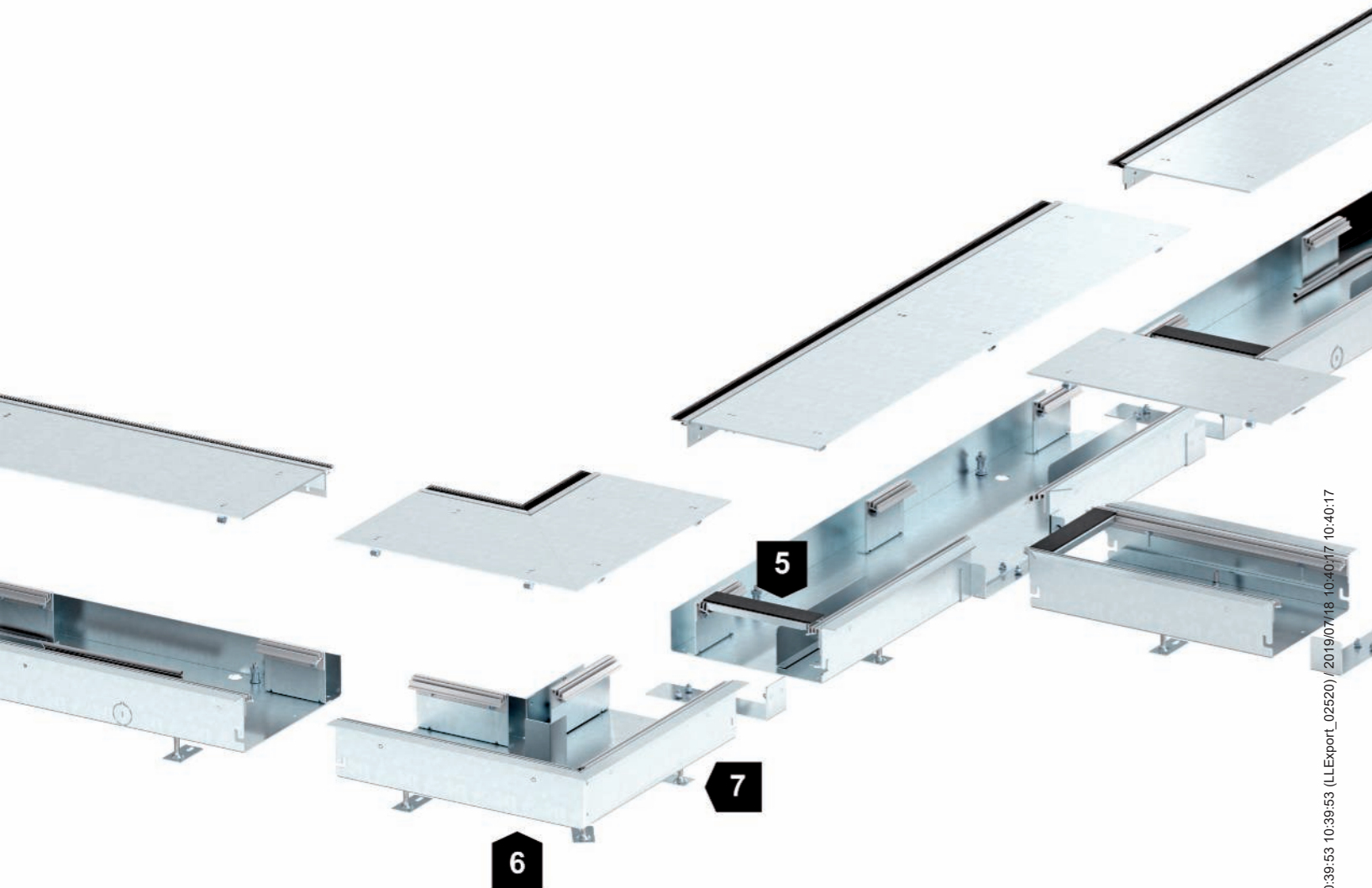

08_UFS / en / 2019/07/18 10:39:53 (LLExpert_02520) / 2019/07/18 10:40:17 10:40:17

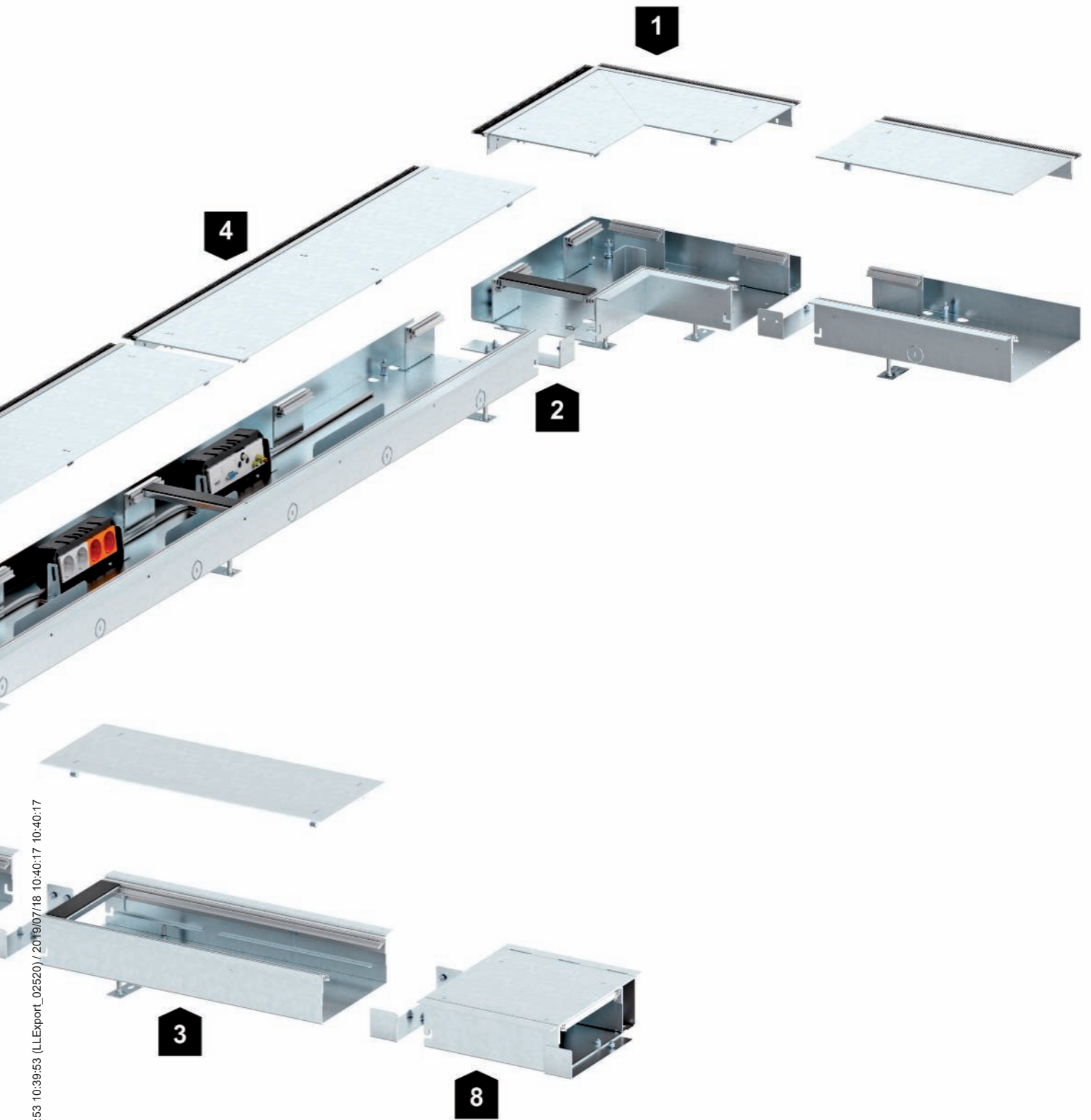

Usable cross-sections



Supply trunking

The supply trunking has a cross-section of 11,008 mm². The table on this page indicates how many cables fit into the trunking.

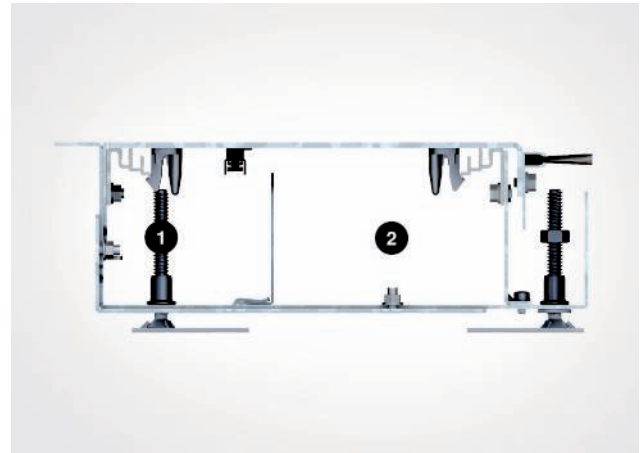

Installation trunking

The first trunking compartment offers a cross-section of 4,231 mm². The second trunking compartment has a usable cross-section of 7,306 mm². Depending on the installation position of the devices, this area can only be used in a limited manner for cable routing.

Number of cables in a supply trunking

Cable diameter in mm	Cable cross-section in mm ²	Number of cables
5	25	440
6	36	306
7	49	225
8	64	172
9	81	136
10	100	110
11	121	91
12	144	76
13	169	65
14	196	56
15	225	49
16	256	43
17	289	38
18	324	34

Number of cables in an installation trunking

Cable diameter in mm	Cable cross-section in mm ²	Number of cables in trunking compartment 1	Number of cables in trunking compartment 2
5	25	173	292
6	36	120	203
7	49	88	149
8	64	68	114
9	81	53	90
10	100	43	73
11	121	36	60
12	144	30	51
13	169	26	43
14	196	22	37
15	225	19	32
16	256	17	29
17	289	15	25
18	324	13	23

Noise prevention and impact noise

Minimum requirements

The minimum requirements for structural sound insulation are defined in DIN 4109 "Sound insulation in buildings". General information on the topic of sound insulation and the installation of underfloor systems can be found in the general planner section of the catalogue.

Qualified tests to determine the transmission of air and footfall sound were carried out together with the MÜLLER BBM GmbH testing institute in Planegg, Munich, for the OKB brush bar trunking system.

The transmission of air and footfall sound was investigated for both vertical sound transmission, i.e. from storey to storey, and horizontal sound transmission, i.e. from adjacent rooms.

The test was carried out in a floating screed construction.

Noise evaluation

The following section evaluates the test results. With regard to the evaluated reduction of footfall sound of the screed without a floor system, statements made below can be considered as approved.

The required noise measures, based on the available test certificates, for the use of the type OKB trunking system in offices can be summarised as follows:

Horizontal transmission of air and footfall sound

In comparison with other systems, the brush formation at the edge produces higher sound transmission. If the trunking system runs under partitions with noise protection requirements, then noise protection insulation (cf. Point 4.2) must be installed in the partition area. It is then suitable for achieving the evaluated noise insulation dimensions of partitions up to $R'w = 48$ dB and evaluated standard footfall sound levels of $L'n, w \leq 53$ dB.

Vertical transmission of footfall sound

The OKB floor system (open trunking system, screed-flush) does not lead to a decrease of the required evaluated footfall sound reduction of a floating cement screed with regard to vertical transmission of footfall sound.

Data taken from Report M88034/06 of 29 July 2014.

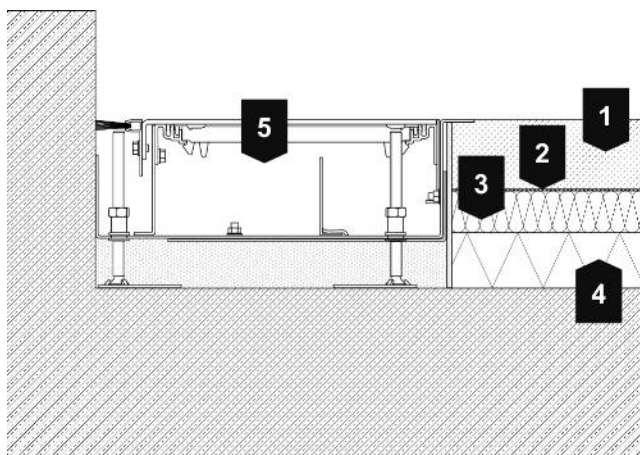

1	50 mm cement screed, CEM I 52.2 N, mass relative to area $m' = 15$ kg/m ²
2	0.2 mm PE film
3	30 mm noise insulation damping, dynamic stiffness $s' = 15$ MN/m ³
4	40 mm heat insulation, polystyrene EPS 100/035
5	38 mm installation trunking

System 55 for thin screed layers

Low floor structure heights require special solutions for underfloor installations. System 55 is used for screed heights of 55 mm plus floor covering or higher. It is ideal for supplying large areas, particularly in offices and administrative buildings. The duct and trunking systems can be adapted to meet the specific requirements of the construction project and comprise screed-covered and screed-flush solution variants.

The System 55 service outlets have a fixed construction height of 55 mm. This allows simple installation of sockets, data and multimedia connections from the Modul 45 series from OBO Bettermann.



Screed-flush system

The open, screed-flush OKA trunking system provides the highest level of flexibility in cable routing. The lids of the trunking can be opened, meaning that the electrical installation can be accessed at any time.





Scree-covered system

The closed, scree-covered EÜK underfloor system allows invisible cable routing, hidden in the scree, via installation pipes.

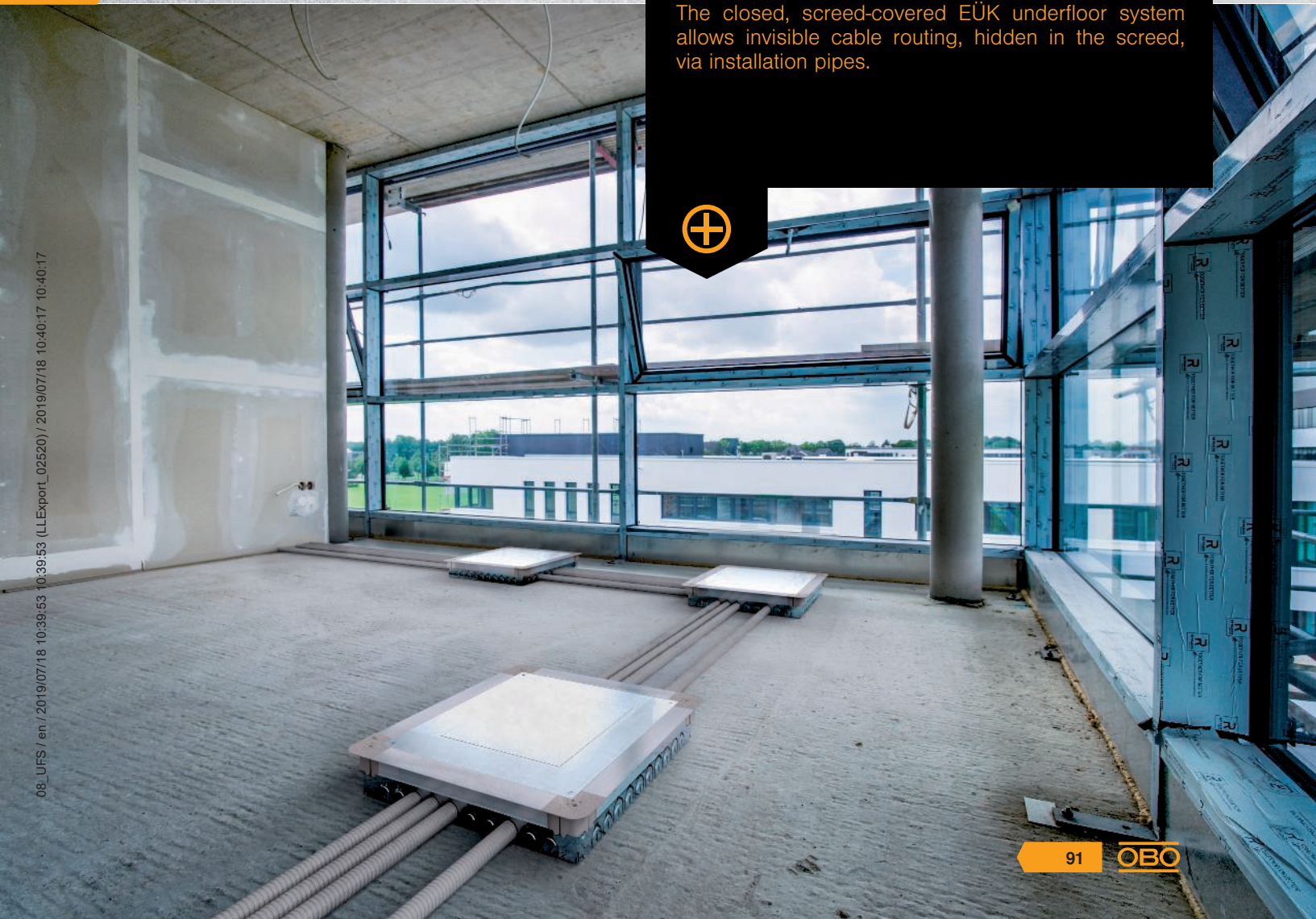

Screed-covered system EÜK

Underfloor sockets EÜK

The underfloor sockets serve either as intersections of the cable sections or allow the installation of square and rectangular service outlets. The underfloor sockets can be adjusted to up to a screed height of 80 mm, as required.



System sizes, EÜK

The device sockets and junction and branch boxes are available in two system sizes. In the system size 250, the dimensions are 367 x 410 mm, whilst in the 350 sizes, they are 467 x 510 mm.

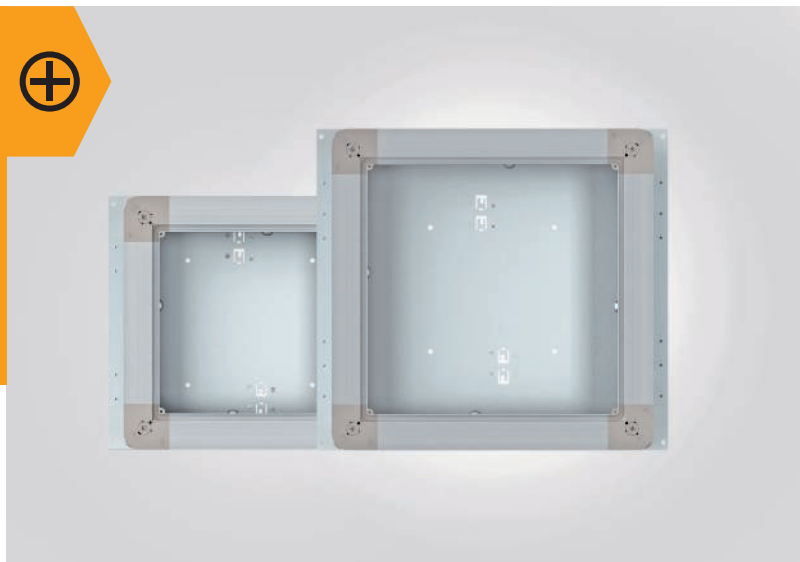

EÜK cable routing

Cables are routed via installation pipes of size M20 from a screed height of 55 mm. With greater screed heights, installation pipes of up to M32 are suitable. Up to ten installation pipes can be inserted per side, depending on the pipe size. The cable pipes are installed via a prepared empty pipe entry in the side walls of the underfloor sockets.

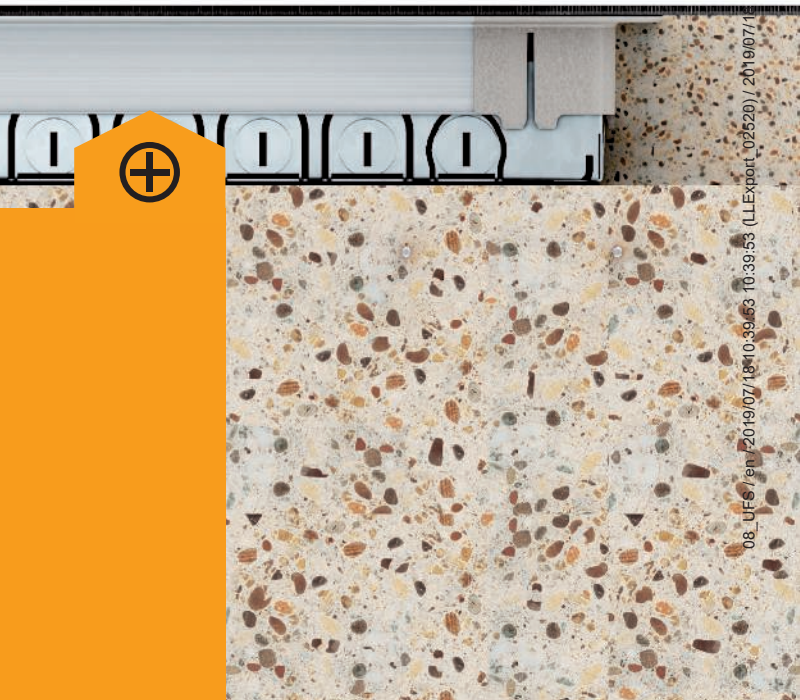

Screed-flush system OKA



OKA device installation

With the OKA system, the installation of service outlets takes place using trunking installation units, which can be mounted at any point in the trunking section. This means that the trunking section is only used for cable routing, without any reduction of the usable cross-section.



Two OKA variants

The screed-flush trunking of the OKA system is available in two versions – with a flexible side wall and with a closed floor trough. The two variants can be combined easily.



OKA cable routing

When using a lot of cables, the open, screed-flush OKA trunking system is ideal. The OKA installation trunking is available in the widths 200, 300, 400, 500 and 600 mm and allows secure, flexible cable routing.

08_OFS / en / 2019/07/18-10:39:53 (LLEExport-02520) / 2019/07/18-10:40:17

Service outlets

The GES 55 service outlets are suitable for installation near workplaces of electrical devices, such as sockets, data and multimedia connections, in rooms with dry-cleaned floors. The service outlets can be used universally for the screed-covered and screed-flush systems. Two plastic variants with swivellable cord outlet are available: In round or square designs. The lid can be opened easily using a handle clamp and contains a recess to accept the floor covering. The scope of delivery of the service outlet contains two installation housings for vertical mounting of Modul 45 devices and four strain reliefs.



Device mounting in System 55

Modul 45 devices are installed vertically in the System 55 service outlets. The various installation frames allow simple mounting of power, data and multimedia connections in the service outlet.

Depending on the design of the installation frames and sockets, angular and/or straight connectors can be used. The installation of data connection modules is possible with Modul 45 data technology supports.

Suitable for straight connectors

Maximum equipment can be achieved using 0° sockets. Either individual sockets or 2x + 2x or 3x + 1x socket combinations can be used.

Suitable for angular connectors

This type of installation uses single sockets, which are installed rotated through 90°. The spacing of the sockets means that the angular connectors do not impede each other.

Variants

A total of two plastic service outlets, in round or rectangular form, are available, each in the colours iron grey or graphite black.



Installation frame and mounting plates

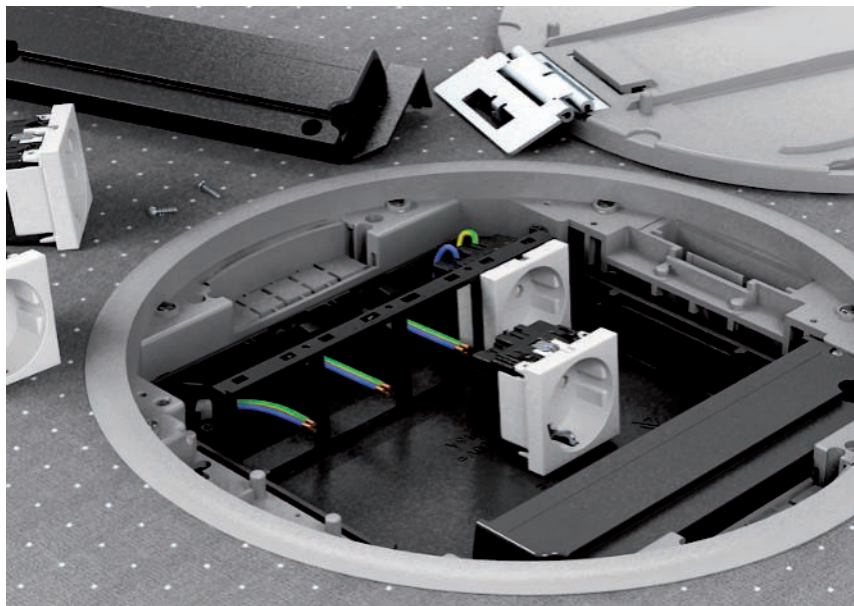

Modul 45 installation

Various installation frames are available for the installation of the Modul 45 devices in the service outlet, allowing quick, flexible mounting.

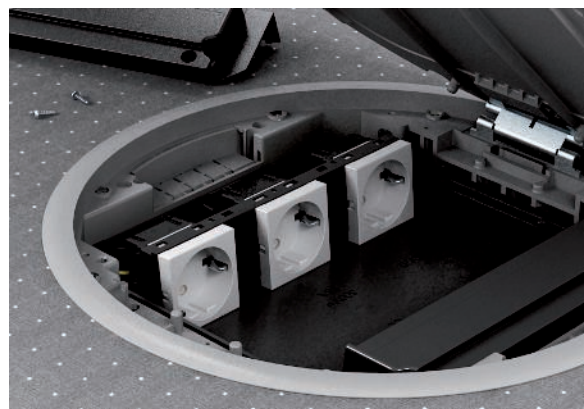
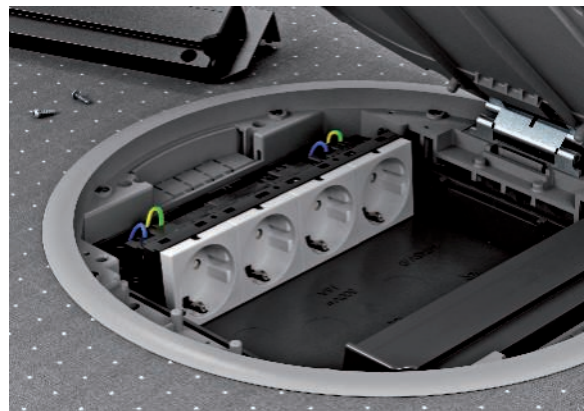

Mounting plates

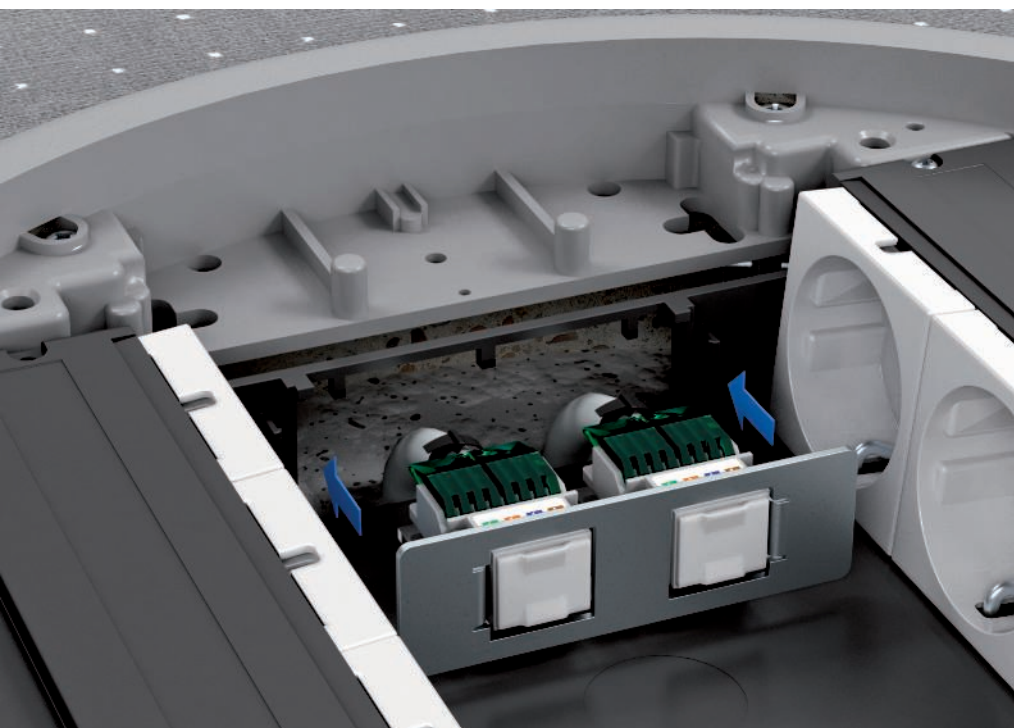

Installation of data technology

Besides the mounting in the installation frame of the service outlet, if there are space problems, additional data modules can be installed in the mounting plates. Each mounting plate can accept two data modules.

Installation and floor cut-out dimensions

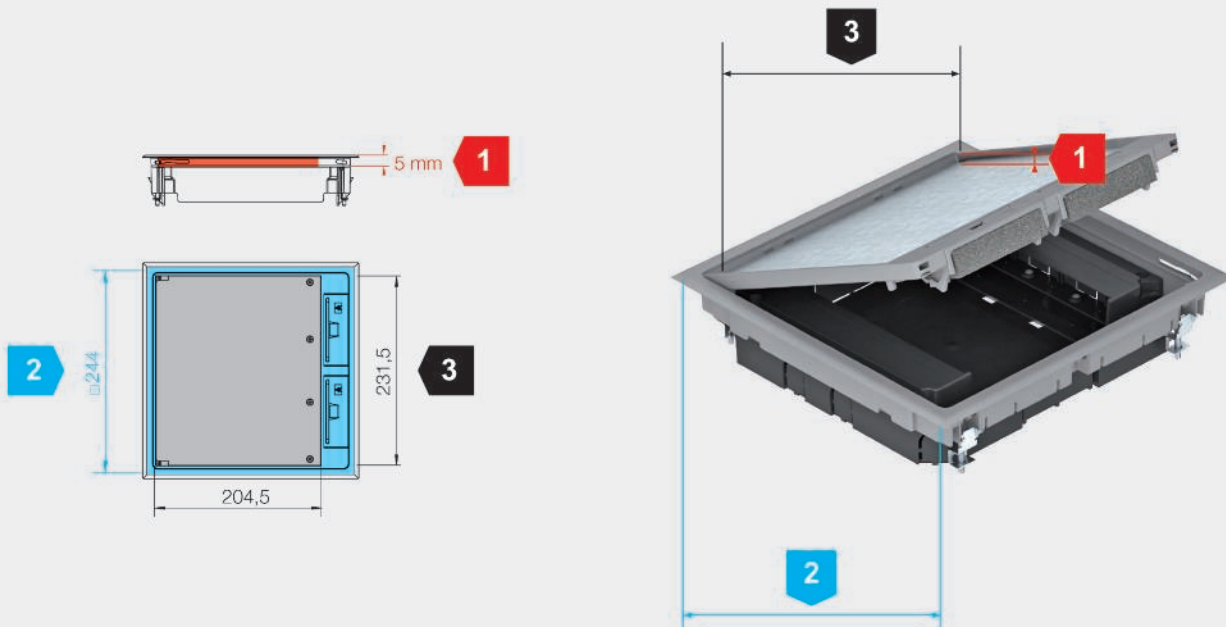

1

Frame height for the floor covering in the lid (red dimensions)

The frame height data relates to the maximum floor covering thickness, including adhesive. If, in the figure, several heights are specified, then the frame height can be changed during construction: By adding or removing spaces, it is possible to adjust the desired frame height to the floor covering. In the as-delivered state, the frame height is usually 5 mm.

2

Floor cut-out for the installation of service outlets (blue dimensions)

The dimensions for the floor cut-out should be considered as target dimensions for correct installation of the service outlet in the floor. They are only generally required for the floor cut-out in system floors. When mounting service outlets in the EÜK screed-covered duct system or in the OKA open trunking system, they need not be taken into account, as these systems offer prefabricated mounting lids with matching installation openings.

3

Internal dimension of the lid to determine the floor covering cut-out (black dimensions)

The dimension data relates to the internal dimension of the lid and is used to calculate the floor covering cut-out. Depending on the type of floor covering, appropriate reductions should be taken into account, e.g. for expansion gaps.

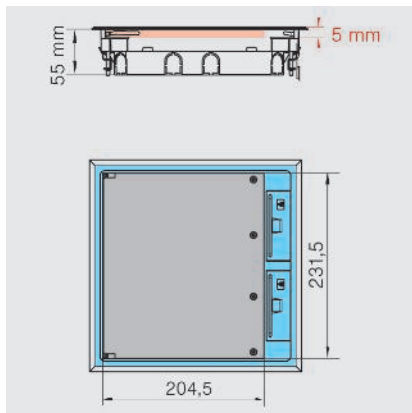

Nominal size 9, type GES9 55

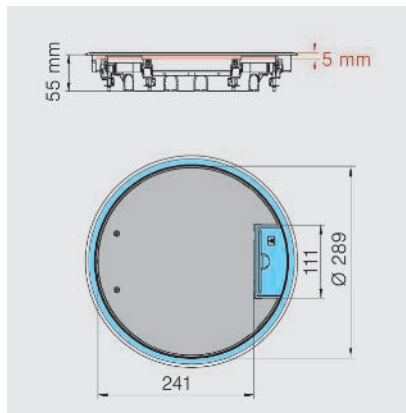

Nominal size R9, type GESR9 55

Installation principle, EÜK

System components

1	Underfloor device socket
2	Mounting lid
3	Service outlet
4	Installation frame for Modul 45 accessories
5	Mounting plate for the installation of data sockets

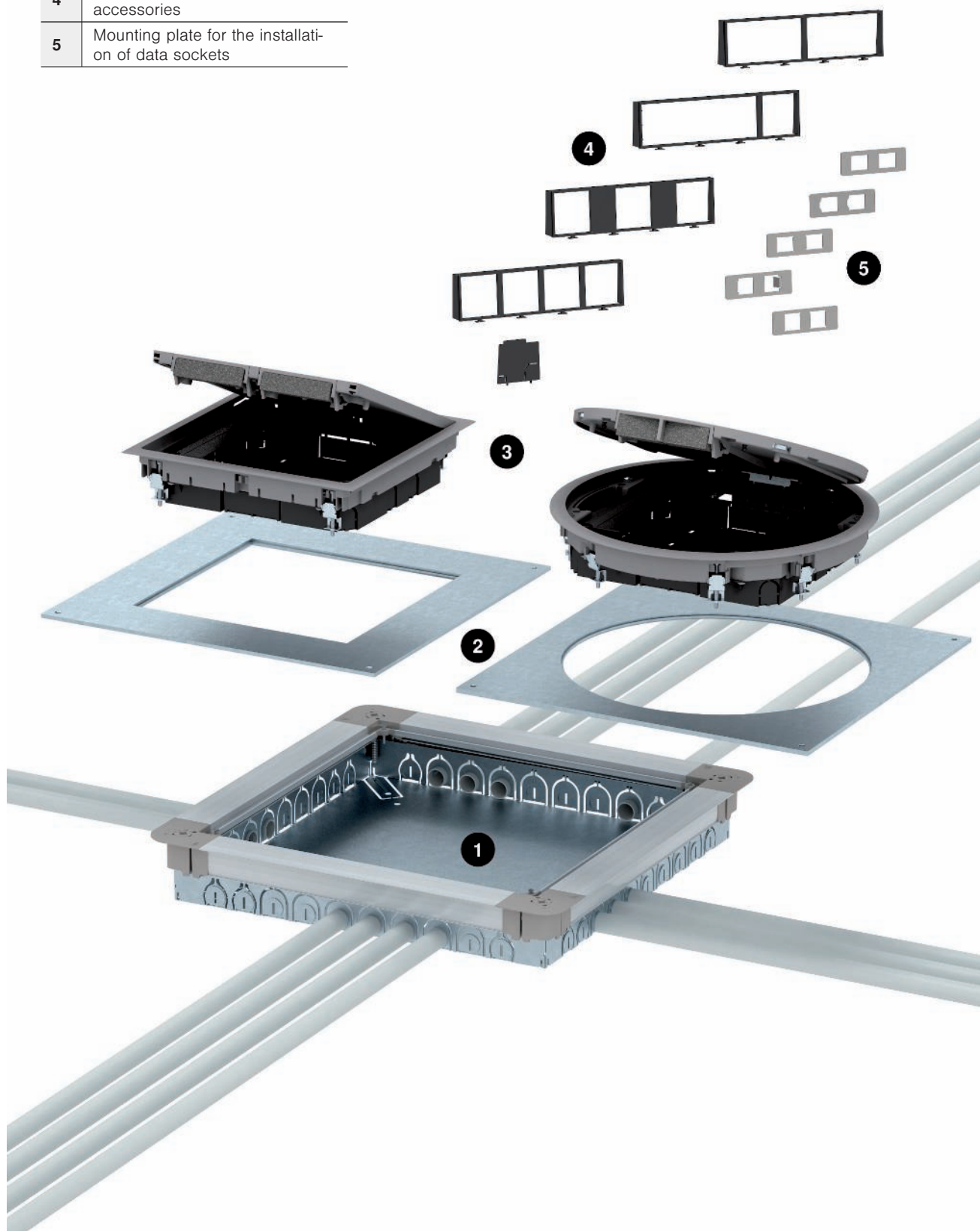

Installation principle, OKA

System components

1	OKA-G installation trunking (base only)
2	Height-adjustment unit for lid butt support
3	Extension unit for OKA-G and OKA-W
4	OKA-W installation trunking (base only)
5	Height-adjustment unit
6	Separating retainer
7	Lid butt support
8	Mounting lid
9	Service outlet for System 55

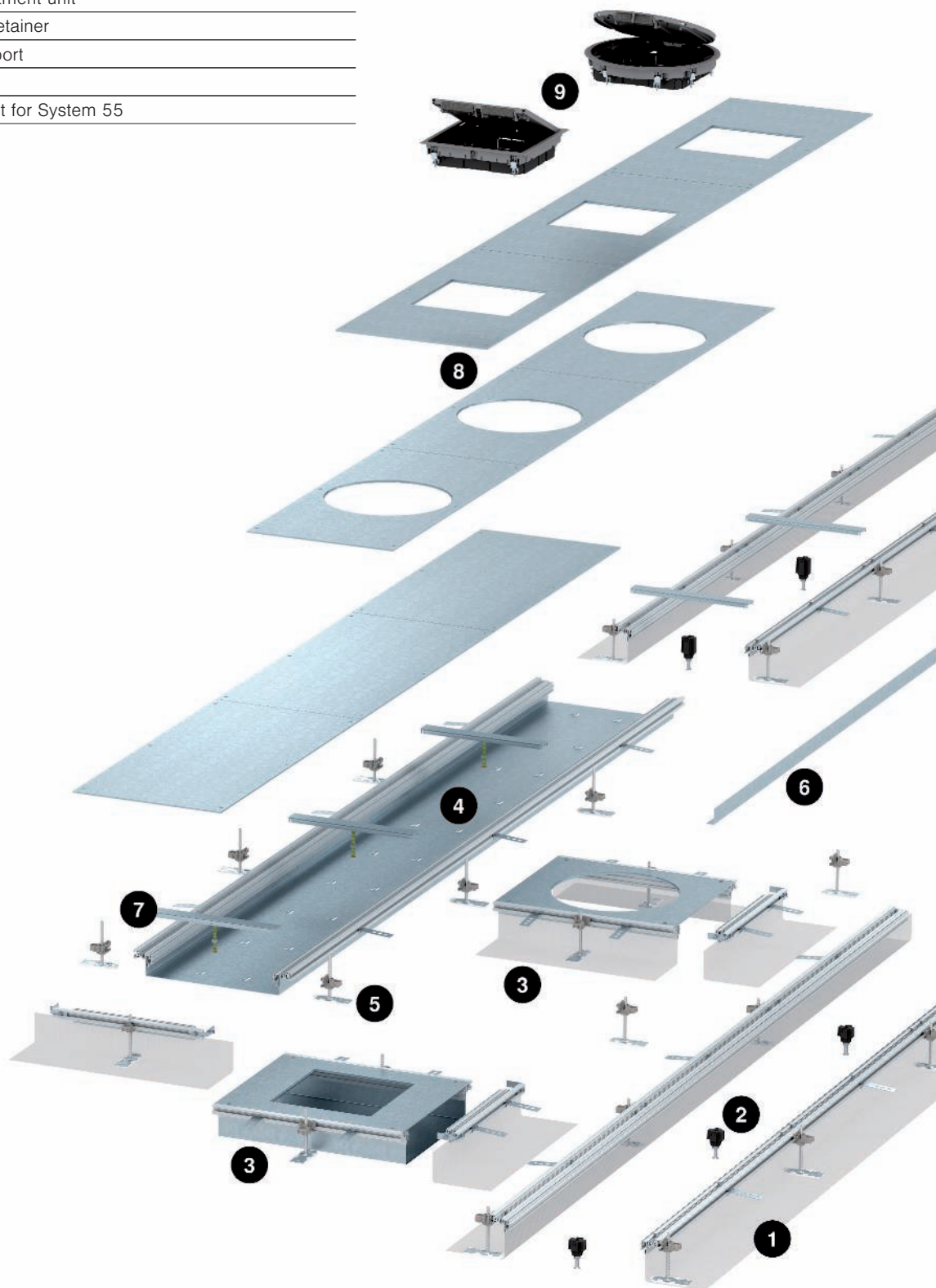

Standard data

To DIN EN 50085-1 and DIN EN 50085-2-2

Class		Underfloor sockets type UGD 55	Trunking system OKA	GES 55
6.2	According to impact resistance for installation and application			
6.2.5	Electrical installation trunking systems for impact energy 20 J	20 J	20 J	5 J
6.3	According to temperatures, as specified in Tables 1, 2 and 3			
Table 1	Minimum storage and transport temperature ± 2 °C	-25 °C	-25 °C	-15 °C
Table 2	Minimum installation and application temperatures ± 2 °C	+5 °C	+5 °C	+5 °C
Table 3	Application temperatures ± 2 °C	+60 °C	+60 °C	+60 °C
6.4	According to the resistance against fire spread			
6.4.2	Electrical installation trunking systems which do not permit the spread of fire	x	x	x
6.5	According to the electrical conductivity			
6.5.1	Electrical installation trunking systems with electrical conductivity	x	x	
6.5.2	Electrical installation trunking systems without electrical conductivity			x
6.6	According to the electrical insulation property			
6.6.1	Electrical installation trunking systems with electrical insulation capability	x	x	
6.6.2	Electrical installation trunking systems without electrical insulation capability			x
6.7	According to the protection ratings offered by the housing or casing to EN 60529:1991			
6.7.1	According to protection against ingress of solid foreign bodies	x	x	x
6.7.2	According to protection against ingress of water	x		x
6.102	According to resistance to vertical loads affecting a small surface area			
6.102.2	Electrical installation trunking systems for 750 N			
6.102.7	Electrical installation trunking systems for 3,000 N	x	x	x
6.103	According to resistance to vertical loads affecting a large surface area			
6.103.3	Electrical installation trunking systems for 5,000 N		Not tested	



Planning checklist

When planning an underfloor system for low screed heights, the following points should be observed:

- ✓ Matching of the floor structure (screed height, screed type, insulation layers, sealing, etc.) with the architecture
- ✓ Observe the minimum installation depths of device installation units
- ✓ When selecting the nominal trunking sizes take sufficient assignment reserves into account
- ✓ Matching the structural physics requirements (loads, impact sound, etc.)
- ✓ Select device installation units according to the floor cleaning method
- ✓ Specify the spacing between two underfloor boxes taking the tensile loading and occurring bend radii into account



IBK in-concrete duct system

The requirements for installations in modern buildings develop continuously. The new OBO IBK system is matched to the latest technological standards.



Newly developed. From the ground up.

Easy mounting, robustness and a perfect inclusion in the building, all of these are offered by the new in-concrete system. It is matched to the latest developments and trends in construction, both to the technology of concrete core activation and to current fire protection guidelines.

Thanks to many years of experience in development and project planning for underfloor installations, OBO knows the requirements for in-concrete systems. This is just one of the reasons OBO is the market leader in this field.

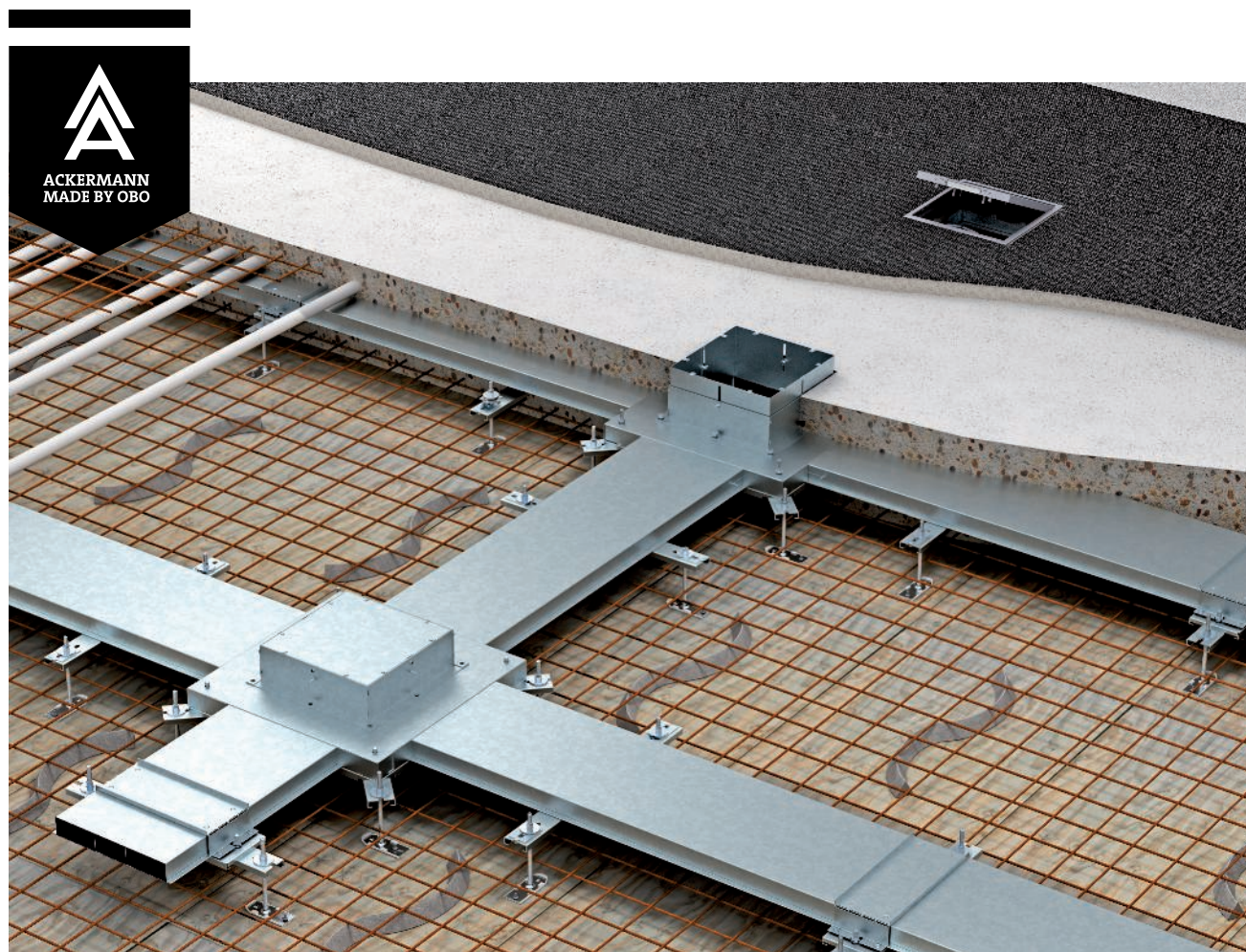

Perfect integration: In-concrete ducts in modern buildings

The in-concrete duct system is suitable for use in concrete floor plates and concrete ceilings, irrespective of whether they are ceilings encased during construction or are ceilings made of filigree plates. Thanks to its continuous height adjustment of ducts and sockets, the system can be adapted to all kinds of project requirements.

The ducts are located in the neutral zone between the upper and lower reinforcement and can also be used for simultaneous concrete core activation, cooling and heating via the floor or the ceiling.



Matched

Example of concrete core activation: The planning for the installation of the IBK system takes all the other factors in the concrete into account.



Comprehensively tested

As with all OBO products, the IBK system has also been tested comprehensively according to all the current standards.



Use of the "neutral zone"

At least 100 mm of concrete beneath the IBK system is required for reasons of fire protection. The "neutral" zone above this can be used.

Use our manufacturer's know-how. In every project phase.

Numerous factors must be taken into account during planning. For this reason, OBO supports planners and installation engineers with comprehensive support, particularly in the planning phase, but also in every other project phase.



Decades of experience

OBO has decades of experience in dealing with almost every kind of underfloor project and on almost every continent. Take advantage of consultation from our team of experts.

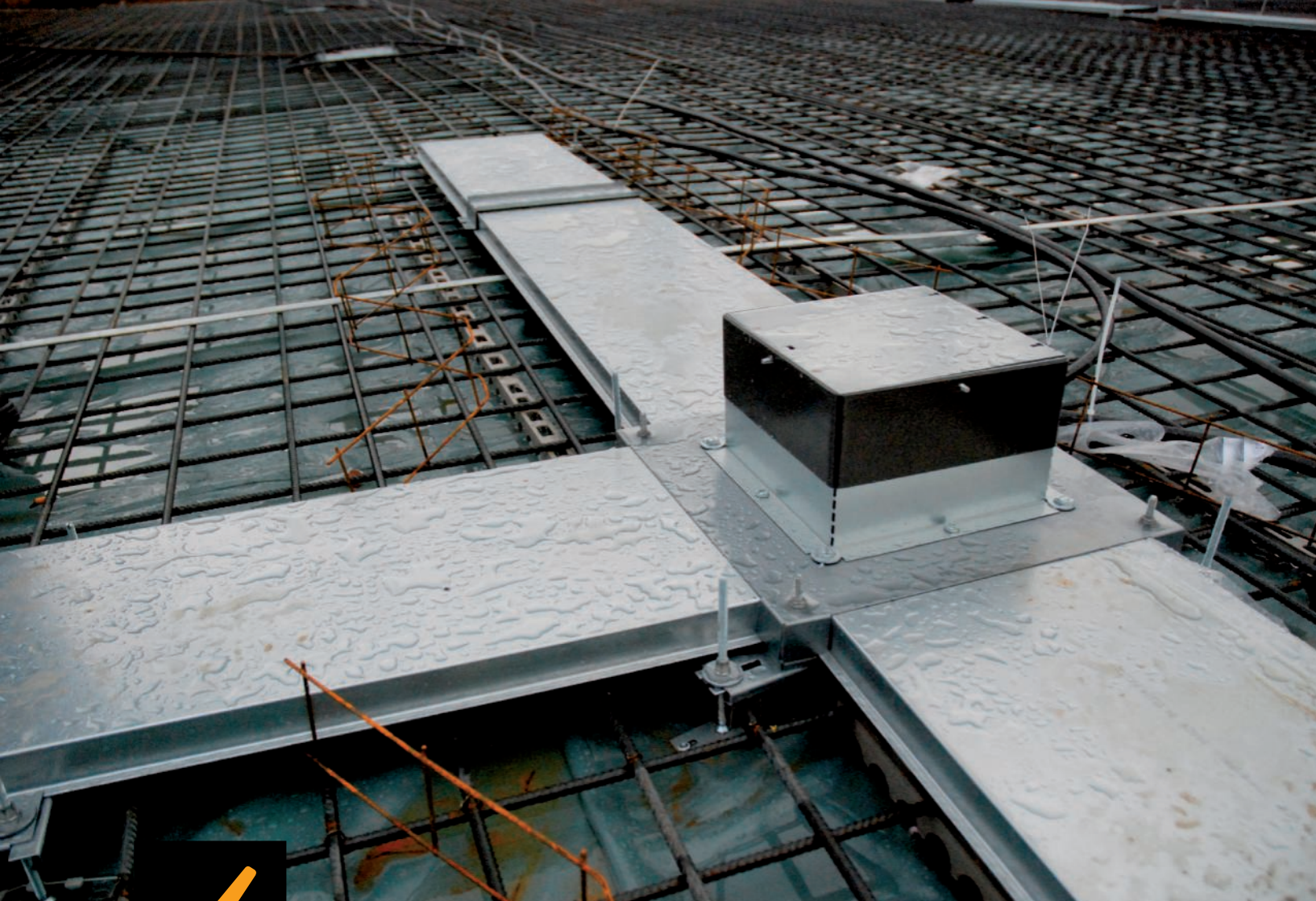

Checklist

When planning and building an IBK system, the system should be compatible with the following factors:

- Architecture
- Statics
- Building systems

On one level: mounting made easy

The IBK system is located between the upper and lower reinforcement of the concrete plate. This means that work between the strands of the steel mats makes mounting difficult. New, swivellable height-adjustment units now allow considerably simpler installation.

Height-adjustment units, standardised for the entire system, are used. The floor plate of the accessory mounting box, the connection elements and the supports are all the same height.



Flexible mounting

The freely swivellable height-adjustment units allow easy system mounting between the strands of the reinforcement.





Completely released

Simply remove the height-adjustment unit, insert it between the reinforcements and then fasten it to the socket body again.



One adjustment height

All the elements are at the same height: Simply adjust all the components to this height and begin with mounting.

IBK: robust, closed and secure

Details in the construction of the new IBK system ensure very practical benefits. For example, the system remains closed off with a mounting protection lid up to device installation and is therefore protected against dirt without any masking. The protection lid prevents workplace accidents during the construction phase and is so robust that it is unaffected by concrete working and the mechanical processing of concrete areas.



Perfectly prepared

Devices are installed in the top of the IBK socket. No additional mounting lids or empty socket tops are required.



Equipotential bonding

Contact claws on the connectors and the straps on the floor plate ensure equipotential bonding.





Robust construction

All the system components are designed for hard construction site use. They are subject to loads from walking, filling with concrete or compacting with a vibrator.

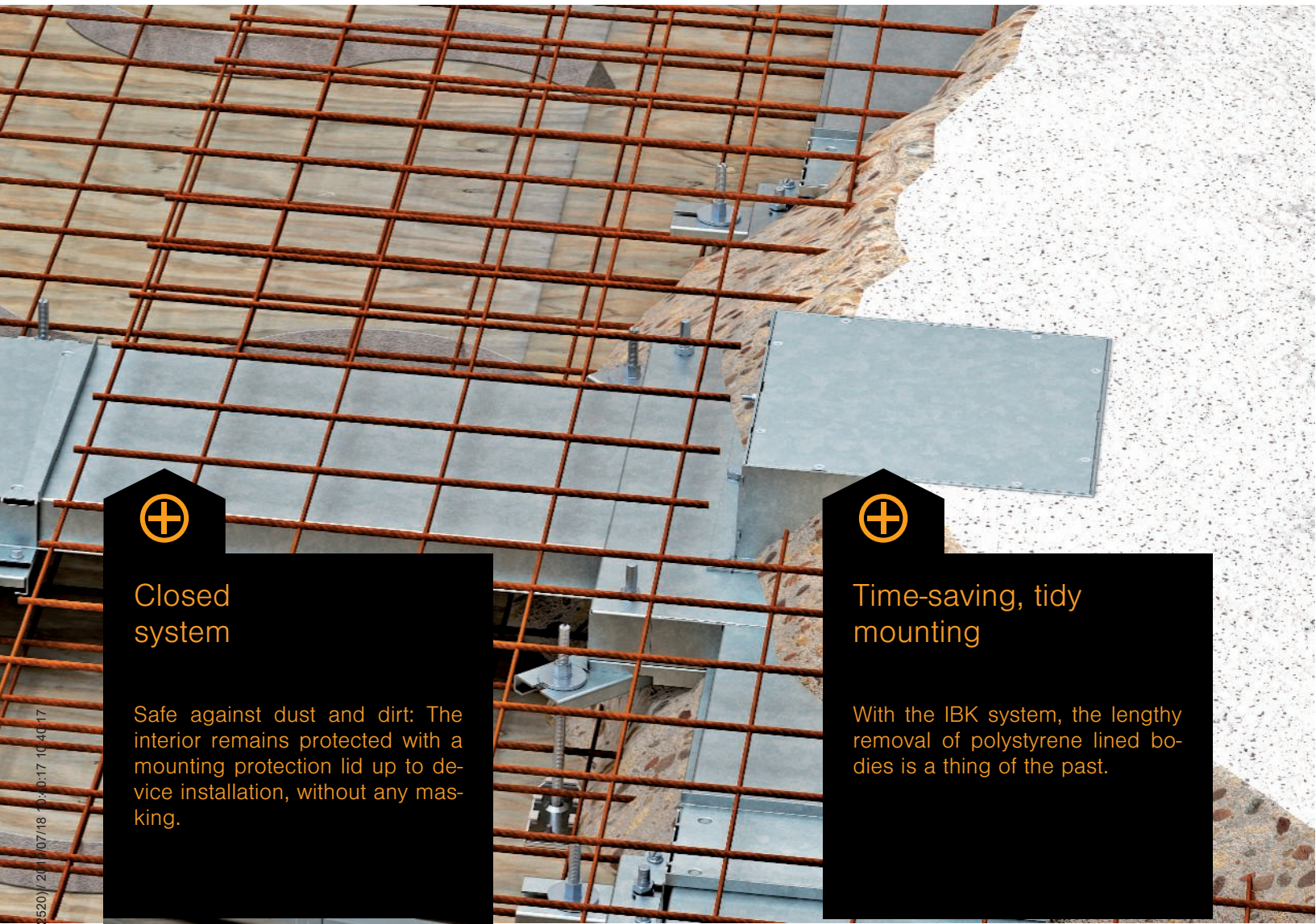

Closed system

Safe against dust and dirt: The interior remains protected with a mounting protection lid up to device installation, without any masking.



Time-saving, tidy mounting

With the IBK system, the lengthy removal of polystyrene lined bodies is a thing of the past.



Seamlessly integrated in the concrete

The integrated lined body of the box, its external wall, can be cast directly in the concrete. Thus, the concrete can be worked to the socket without any cavities requiring later filling. Whilst the outer wall is fixed in the concrete, the height of the inner lined body can be adjusted flexibly. Its side walls are designed for a standard height of 80 mm above the socket.

Perfectly height-adjustable

Before another floor structure is added, for example, screed or fillers, the inner lined body is adjusted by a maximum of 65 mm to the later end height.



Perfect connection

Seamless transition from the concrete to the box body, without any cavities.





Device installation

The IBK system is ready for all the variants of device installation, from the service outlet to the height-adjustable cassette.

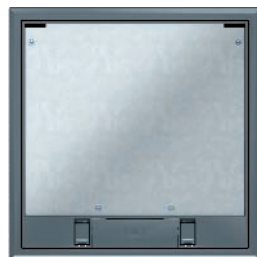

In-concrete duct system installation principle

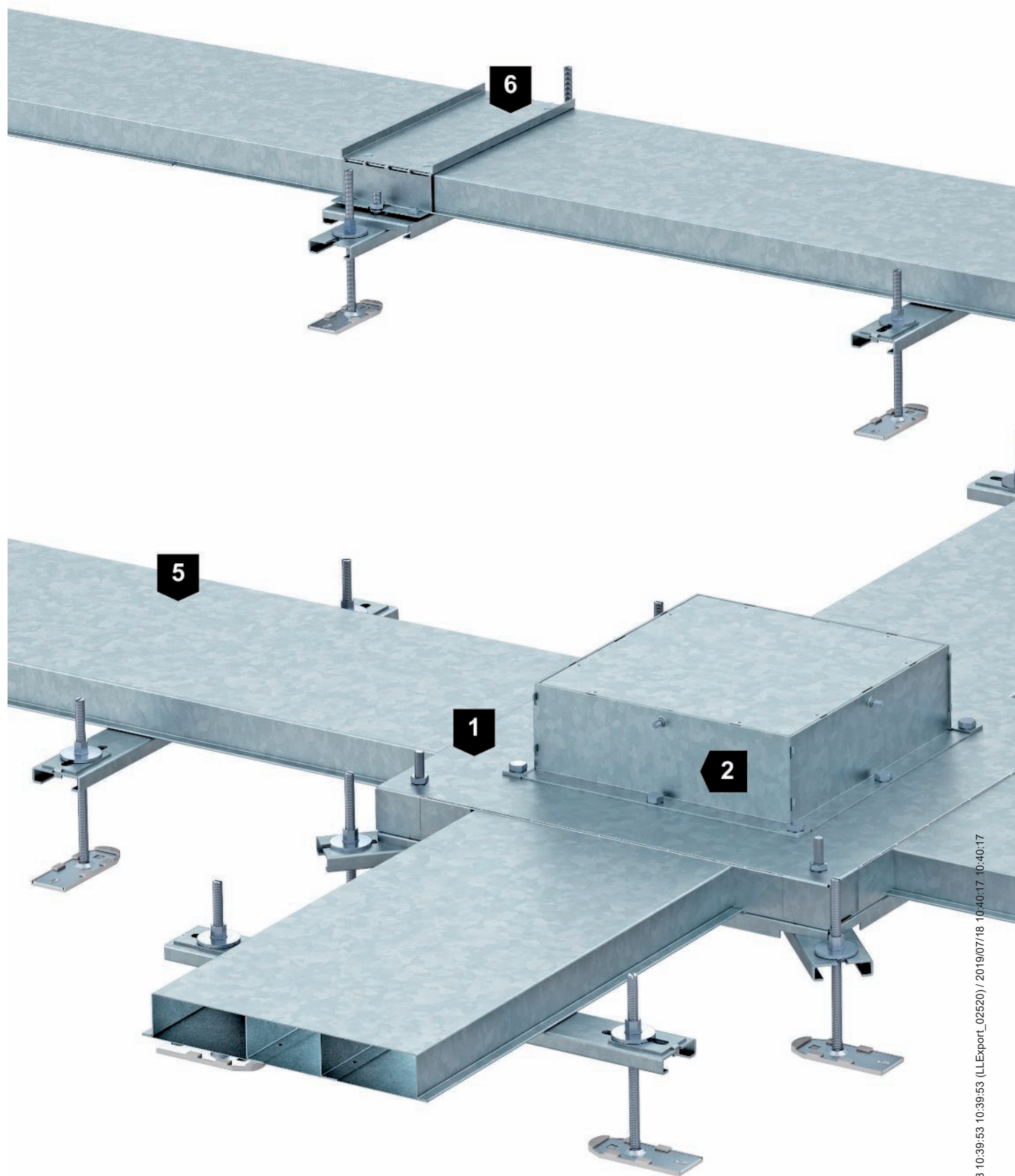

08_UFS / en / 2019/07/18 10:39:53 (LLEExport_02520) / 2019/07/18 10:40:17 10:40:17

1	In-concrete box
2	Cover socket for device installation
3	Mounting protection lid
4	Inner lined body
5	Electrical installation duct, 2- or 3-compartment, 38 or 48 mm high
6	Connection strap with equipotential bonding
7	Duct support
8	Height-adjustment unit

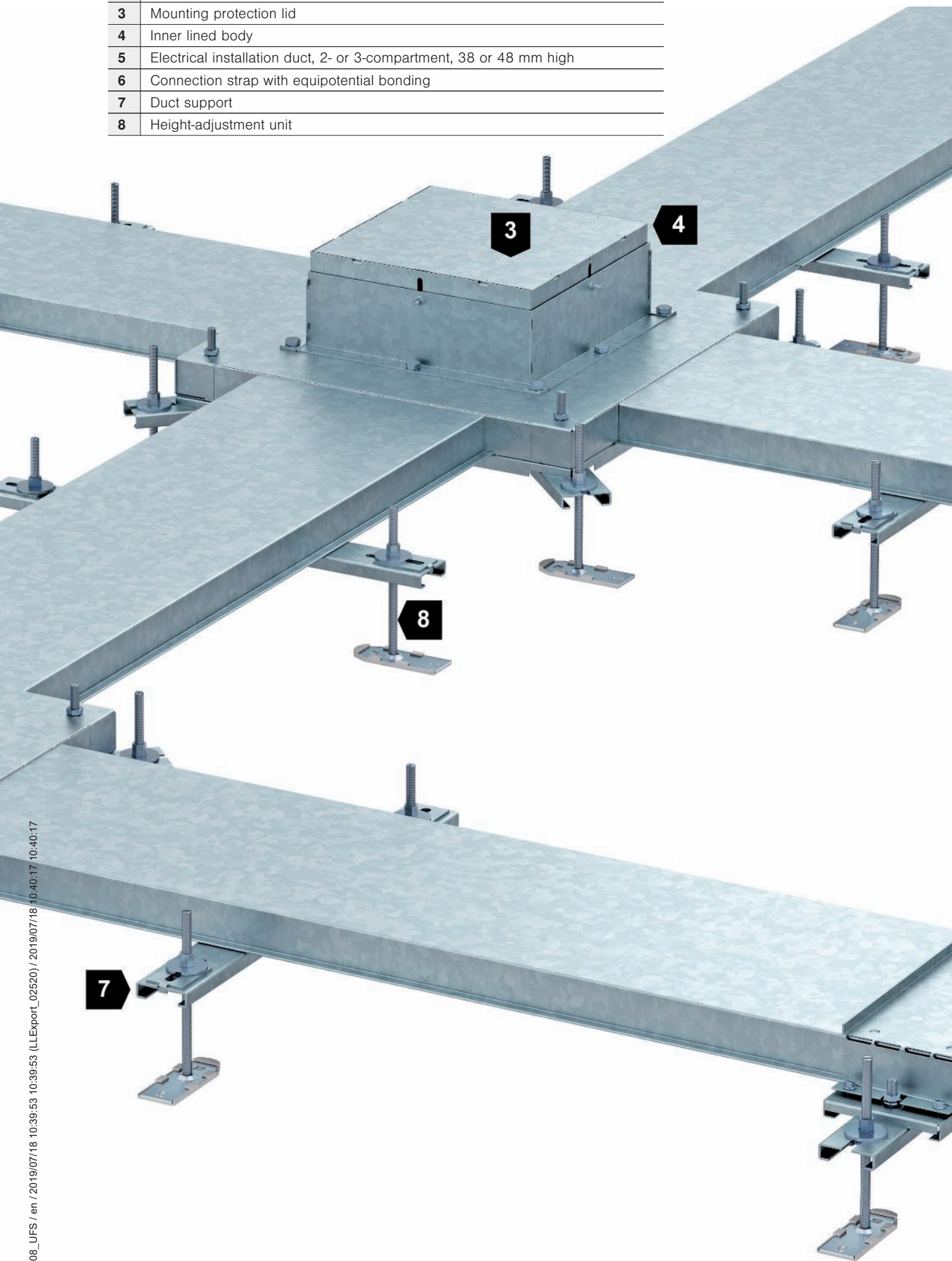

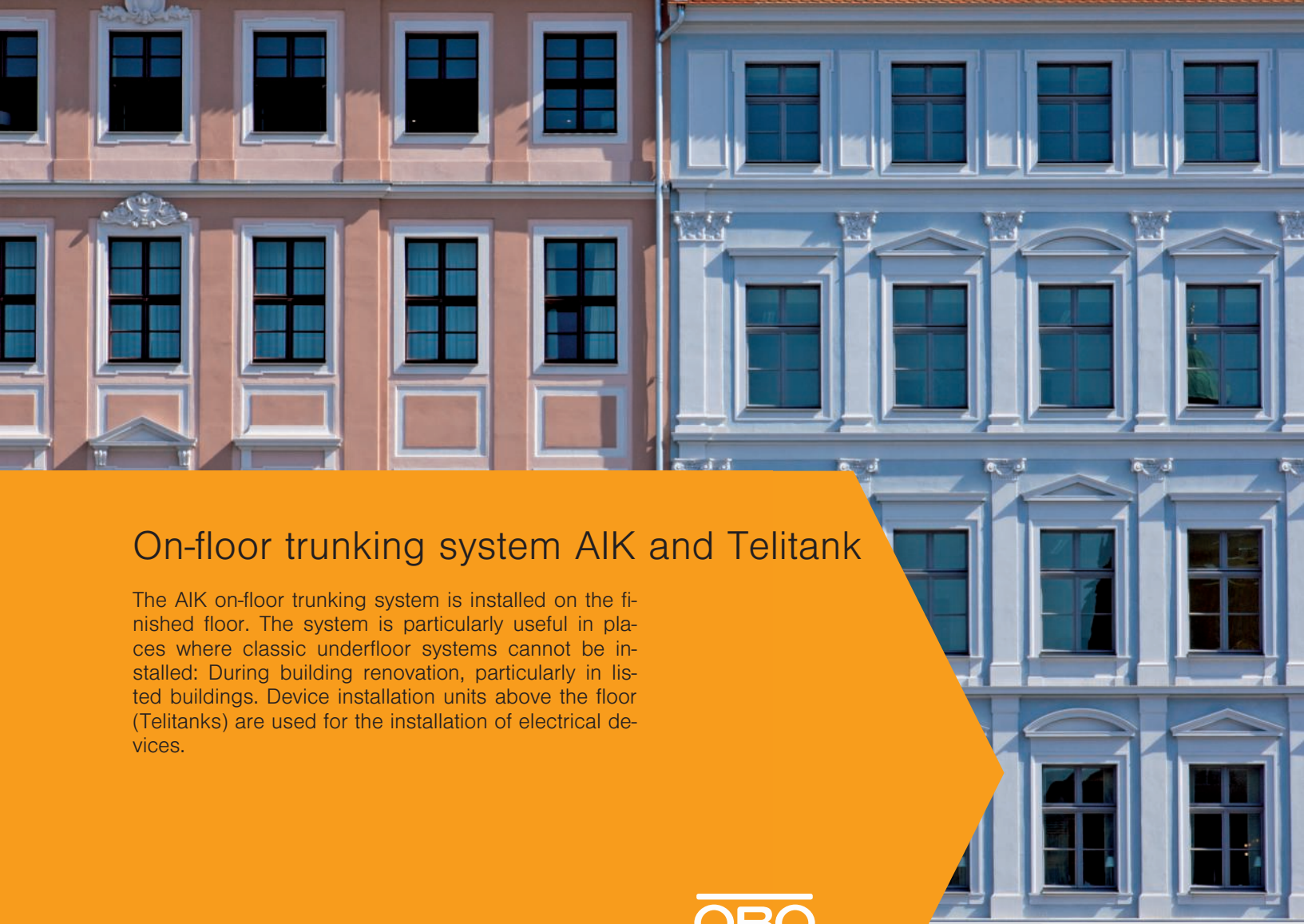

On-floor trunking system AIK and Telitank

The AIK on-floor trunking system is installed on the finished floor. The system is particularly useful in places where classic underfloor systems cannot be installed: During building renovation, particularly in listed buildings. Device installation units above the floor (Telitanks) are used for the installation of electrical devices.



Applications



Old building application

The main area of application of the AIK system is building renovation. Wherever a screed-flush or screed-covered trunking system cannot be used for construction or preservation reasons, the AIK system provides the electrical installation on the floor.



Commercial application

The robust structure and high stability means that the AIK on-floor installation system is also suited to industrial applications, such as workshops or laboratories.



Office application

The AIK on-floor trunking system allows flexible installation at a later date at the edge of office space. The system can also adapt itself rapidly to a changed room situation: The position of the device cover can be changed.



Floor structure



The AIK on-floor trunking system ensures rapid creation of an electrical installation on the finished floor. The trunking sections are available in heights of 40, 70 and 75 mm in the nominal widths 150, 200, 250 and 350 mm.

Service outlet

Rectangular service outlets made of plastic can be inserted in device lids at a trunking height of 75 mm. Due to the limited trunking height, we recommend installing Modul 45 devices vertically. The MT45 module support is used for this.



Sheet steel separating retainers can divide the ducts up into two or three compartments. The separating retainers are automatically conductively connected with the base trough when inserted. The lid thickness is 3 mm. The lid is covered with the floor covering (carpet) during construction.

The system must be routed in the wall area to avoid stumbling blocks in traffic areas.

Telitank on AIK

Telitanks are device installation units protruding above the floor with separate installation spaces for sockets and data technology. The various versions offer space for four to twelve Modul 45 devices.



On-floor trunking system AIK

Mounting

The cut-outs for device installation units are prefabricated. They can be equipped with a service outlet or equipped with a Telitank.

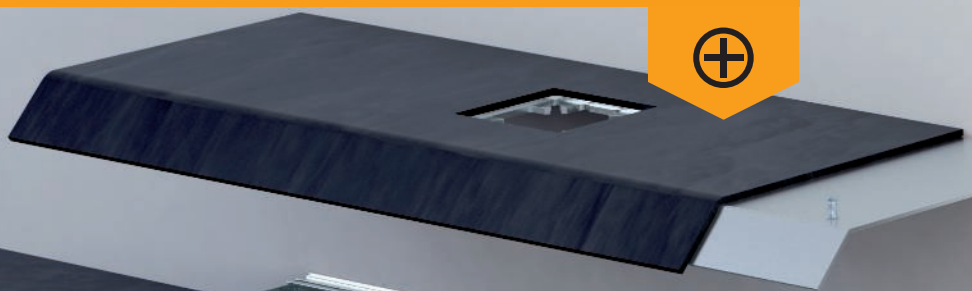

Direction changes

If there are right-angled changes of direction, then the duct bases must be adjusted to the appropriate angle situation. In the case of non-right-angled direction changes, the duct covers must also be modified.



Equipotential bonding

To include the AIK system in the equipotential bonding, the individual trunking bases and side profiles are connected with protective conductor connection brackets. On insertion, the trunking divider automatically contacts with the base.



Floor covering work

The floor covering is laid in such a way that it abuts the trunking bases. The surface of the trunking lids is completely covered with the floor covering. The floor covering is pierced on the lid fixing holes to allow the trunking lid to be screwed to the trunking base.



Telitank installation unit

Telitanks are mounted on the trunking in device lids with the matching system opening. Telitanks offer direct installation options for Modul 45 installation devices or installation devices with a 50 mm central plate.



Installation principle, ALK trunking system

System components

1	On-floor installation trunking
2	On-floor branch trunking
3	Trunking separating retainer
4	Trunking end cover
5	Blanking lid, external corner
6	Blanking lid
7	Blanking lid, T branch
8	Service outlet lid
9	Device connection lid (for Teli-tank mounting)
10	Blanking lid, internal corner

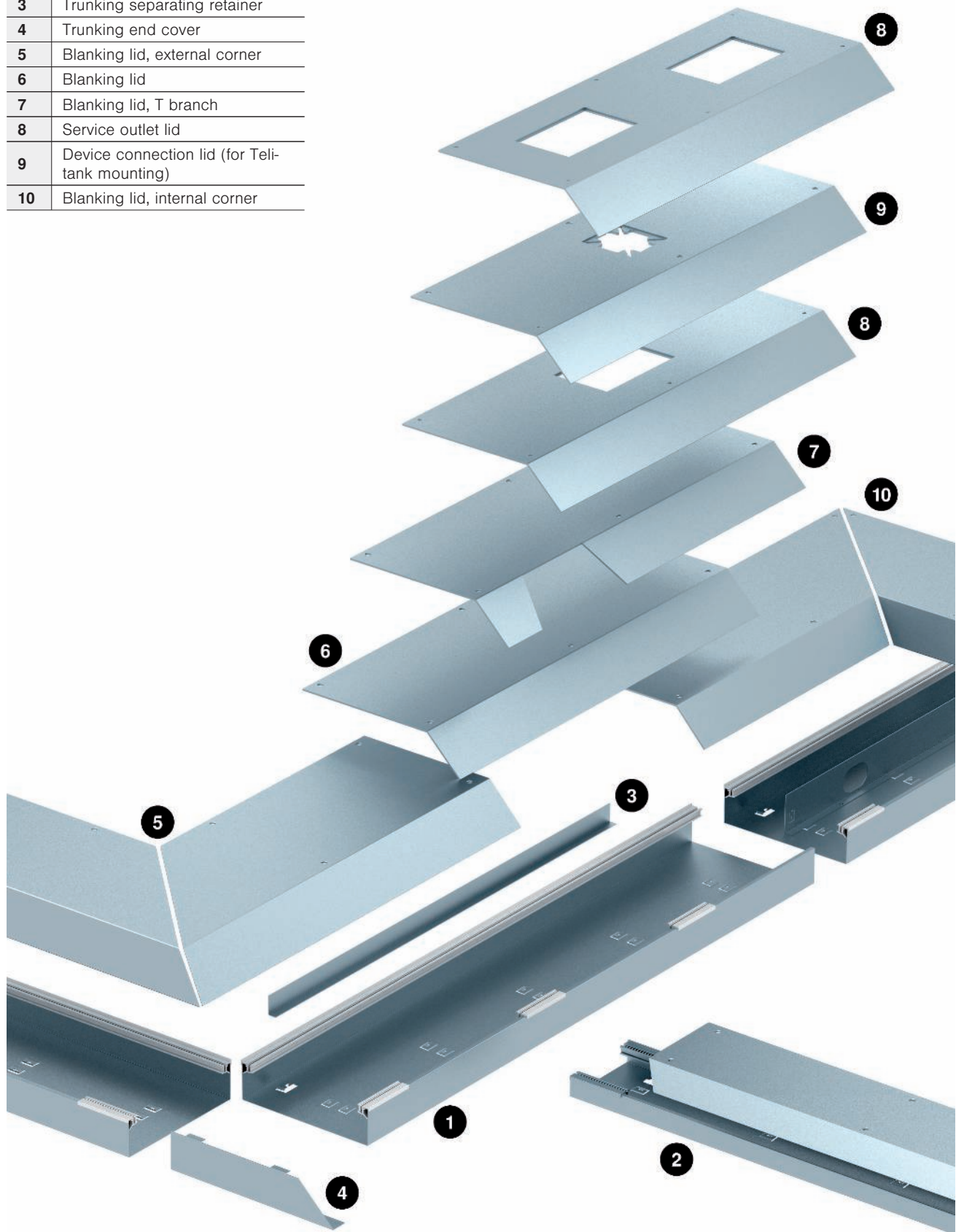

Usable cross-section



The AIK trunking is available in three different heights and four different widths. Please refer to the table on this page to find the correct trunking sizes for the required cable volume. The table provides information on the capacity of the

individual trunking compartments, and also indicates the number of cables to be inserted for two typical application examples. The number of cables relates to a filling factor of 50%.

Number of insertable cables

Nominal size	Nominal size	Available cross-section in mm ²	Available cross-section in mm ²	Available cross-section in mm ²	Total in mm ²	Number of cables	Number of cables
Trunking width	Trunking height	1	2	3		Data cables, Ø 9 mm	NYM 3 x 1.5 mm ² , Ø 11 mm
150	40	1,630	1,120	1,771	4,521	27	18
150	70	3,285	2,090	3,517	8,892	54	36
200	40	2,530	1,120	2,671	6,321	38	26
200	70	5,945	2,090	5,167	13,202	75	50
250	40	3,430	1,120	3,571	8,121	49	33
250	70	6,595	2,090	6,817	15,502	95	64
350	75	11,673	2,250	10,908	24,831	147	98

Equippability with Telitank

Nominal size	T4B	T4L	T8NL	T12L
150	+	+	-	-
200	+	+	-	-
250	+	+	+	+

Equippability with service outlets

Nominal size	GES2	GES4	GES6	GES9
150	-	-	-	-
200	+	-	-	-
250	+	-	-	-
350	-	+	+	+

Telitank variants

According to DIN EN 50085-2-2, Telitanks can be used in dry rooms with dry or wet-cleaned floors. All the Telitank housings are

made of shock-resistant polyamide and thus have a very high load capacity.

Telitank T4L

Telitank T8NL

Telitank T4B

Telitank T12L

Installation in the EÜK screed-covered system

Telitanks are also suitable for the EÜK system. They are mounted with a mounting lid on type UZD underfloor sockets with the DAT mounting opening.



Installation in the OKA screed-flush system

Telitanks can also be integrated in the OKA system: The system also possesses mounting lids with DAT system opening.





GES service outlets

Service outlets supply workstations and other areas in the centre of the room with power and data connections via the floor. There are versions for dry and wet-cleaned floors. Service outlets are suitable for installation in screed-flush and screed-covered underfloor systems, as well as in system floors.

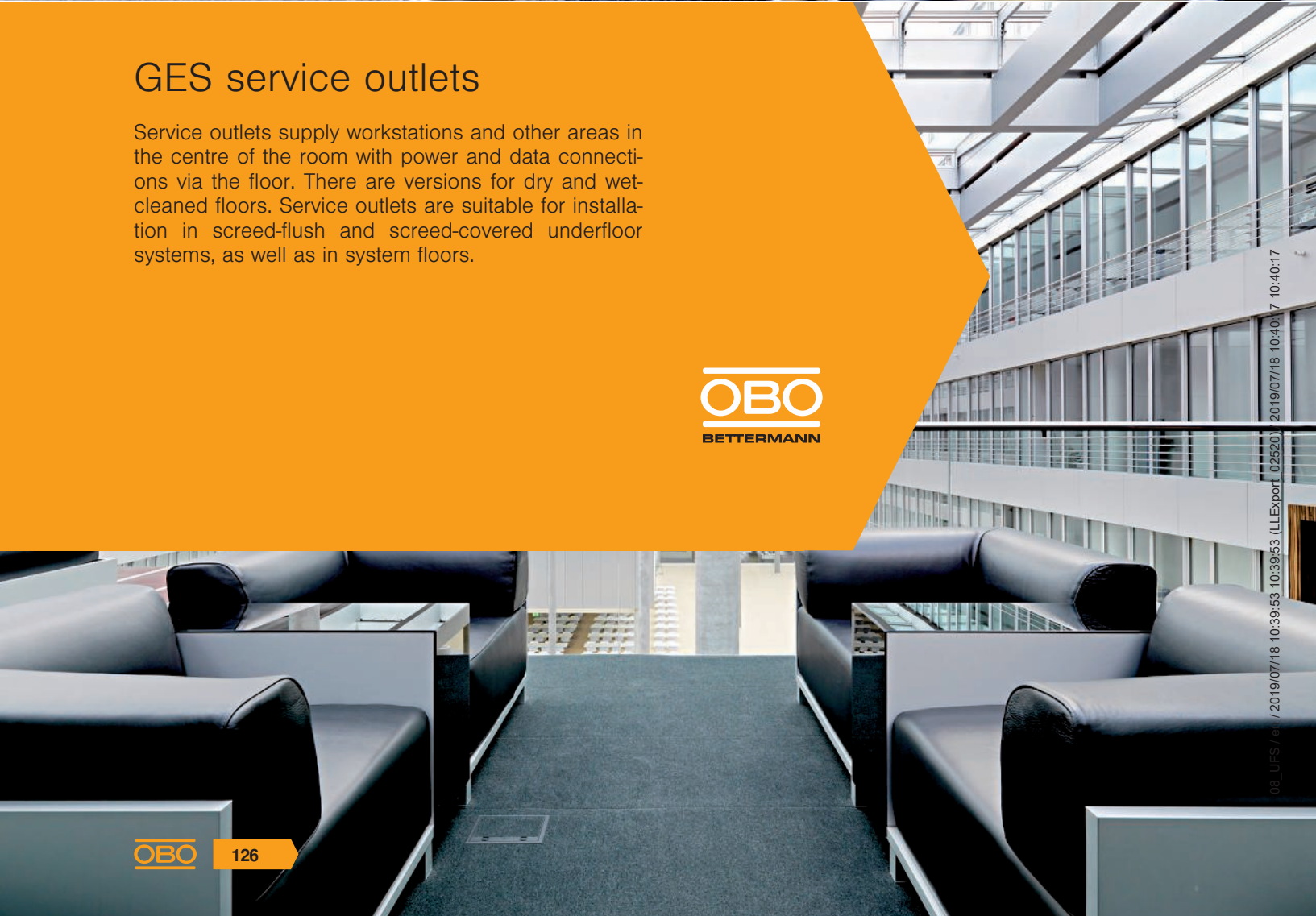

Various colours, shapes and sizes

The GES service outlets are available in round and rectangular versions. Plastic or metal are used as materials.

The plastic version is the tried-and-trusted solution for office installations. It is available in three colour variants. The metallic stainless steel or aluminium versions look refined and can carry an even greater load. Other solutions are available for areas with increased floor load requirements.

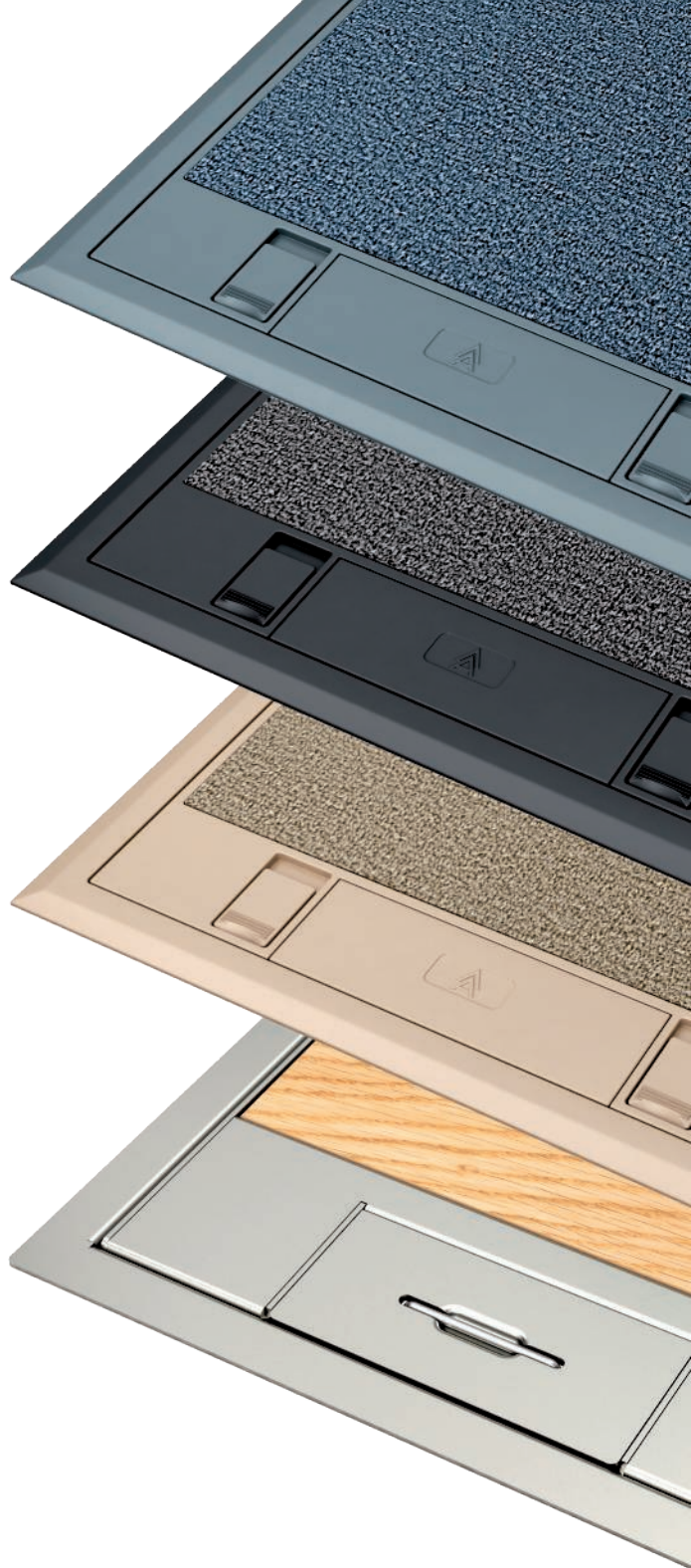

That's what we call variety.

Polyamide, stainless steel or aluminium – the selection is broad, not only for the material of the GES service outlets. The system offers solutions for dry and wet-cleaned floor coverings, such as carpet, PVC or linoleum, as well as parquet, laminate, tiles and stone floors. With the colour range of iron grey, graphite black, grey-beige and stainless steel, the service outlets can be inserted discreetly in any floor covering.



Nominal size 2 with handle clamp
External dimension 118 x 194 mm
3 x Modul 45



Nominal size 4 with locking slider
External dimension 222 x 222 mm
6 x Modul 45



Nominal size 4 with handle clamp
External dimension 222 x 222 mm
6 x Modul 45



Nominal size 4, stainless steel, with handle clamp
External dimension 222 x 222 mm
6 x Modul 45



Nominal size 6 with locking slider
External dimension 274 x 221 mm
9 x Modul 45



Nominal size 6 with handle clamp
External dimension 274 x 221 mm
9 x Modul 45



Nominal size 6, stainless steel, with handle clamp
External dimension 274 x 220.5 mm
9 x Modul 45



Nominal size 9 with locking slider
External dimension 264 x 264 mm
12 x Modul 45



Nominal size 9 with handle clamp
External dimension 264 x 264 mm
12 x Modul 45



Nominal size 9, stainless steel, with handle clamp
External dimension 265 x 265 mm
12 x Modul 45

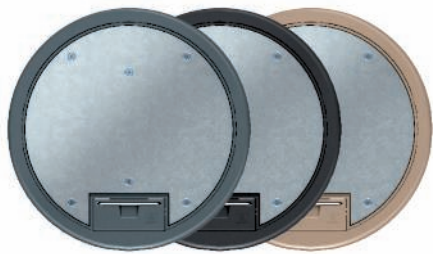

Nominal size R4 with handle clamp
 External dimension Ø 234 mm
 6 x Modul 45

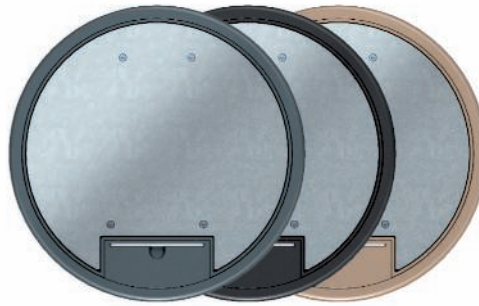

Nominal size R7 with handle clamp
 External dimension Ø 294 mm
 10 x Modul 45



Nominal size R7, aluminium, with handle clamp
 External dimension Ø 294 mm
 10 x Modul 45

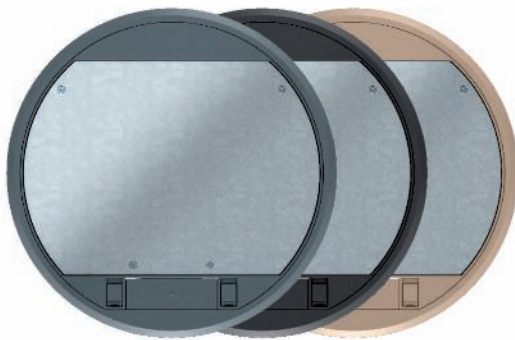

Nominal size R9 with locking slider
 External dimension Ø 324 mm
 12 x Modul 45

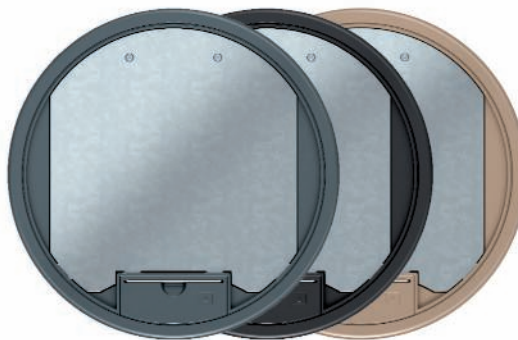

Nominal size R9 with handle clamp
 External dimension Ø 324 mm
 12 x Modul 45



Nominal size R9, aluminium, with handle clamp
 External dimension Ø 323 mm
 12 x Modul 45



Nominal size R9, aluminium
 External dimension Ø 325 mm
 12 x Modul 45



Nominal size R9, aluminium
 External dimension Ø 325 mm
 12 x Modul 45

Rectangular polyamide service outlets

Trusted quality

The trusted rectangular GES plastic service outlets have been installed millions of times around the world. OBO has continuously developed them and adapted them to changing requirements. Today, they possess countless intelligent details, such as cable routing clips, carpet protection frames, reliable edge protection and a locking lid closure system with automatic lid opening.

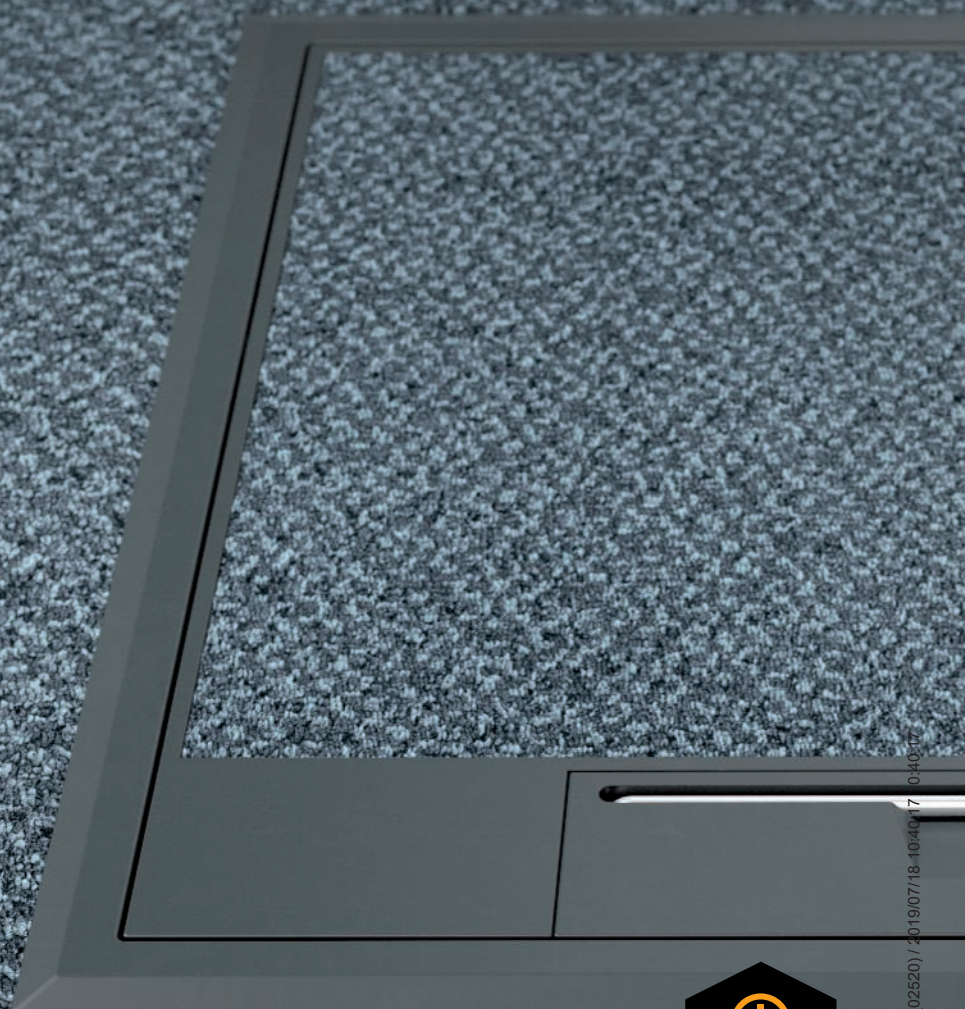

Simple to open

Tried-and-trusted opening mechanism: A handle clamp is integrated in the cord outlet, with which the lid can be opened. Alternatively, service outlets with locking sliders are available.



08_U-S7-enr-2019/07/18-10:40:17_02520)_2019/07/18-10:40:17_0-10:17

Options to equip

The Modul 45 system has established itself as the standard for electrical installations in underfloor systems. The system offers a range of installation solutions for power, data and multimedia technology. It is installed in universal supports and mounting boxes.



Floor covering depth

The floor covering recess in the cover can be increased from 5 mm to 10 mm by using the supplied spacer frame.

Rectangular metal service outlets

Attractive design in stainless steel

The rectangular service outlets with carpet protection frame and hinged covers made of brushed stainless steel stand out through their high-quality design. The installation frame and the solid, 3 mm-thick pressure plate in the lid are made from zinc-plated sheet steel. They provide the necessary stability: Heavy loads are also not a problem.



Swivellable cord outlet

The model has a swivelling stainless steel cord outlet which protects the cable exit in dry and moist-cleaned floors.

Range of variants and installation heights

The unit can be mounted in a minimum installation depth of 80 mm in trunking systems, as well as in raised and cavity floors. In the units of nominal sizes 4, 6 and 9, 6, 9 or 12 Modul 45 devices for power, data or multimedia can be installed.

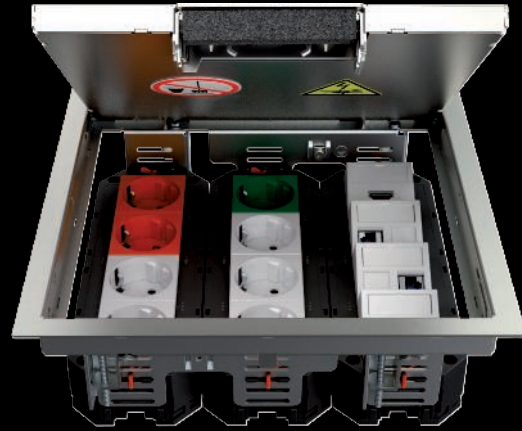

Lowerable mounting box

The service outlet for the installation of power, data and multimedia equipment can be lowered by a maximum of 25 mm in the locking ladder.

Round polyamide service outlets

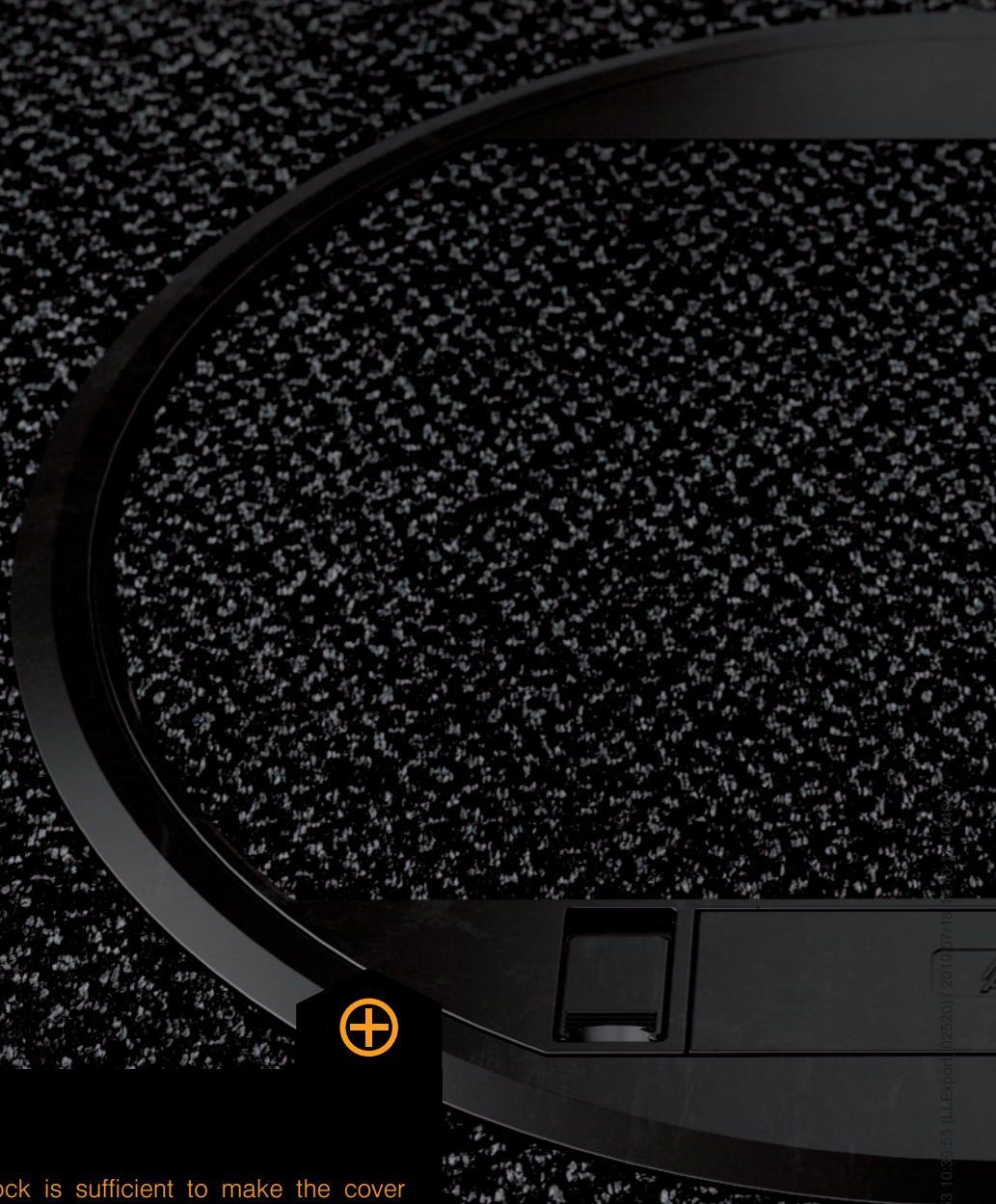

Lid with locking slider

Slight shifting of the active cover lock is sufficient to make the cover open. It also engages again with slight pressure and stays shut. Alternatively, the classic version with a handle clamp is available.

Options to equip

The round GESR9 service outlet can be equipped with up to 12 Modul 45 devices for power, data and multimedia supply using universal supports of mounting boxes.

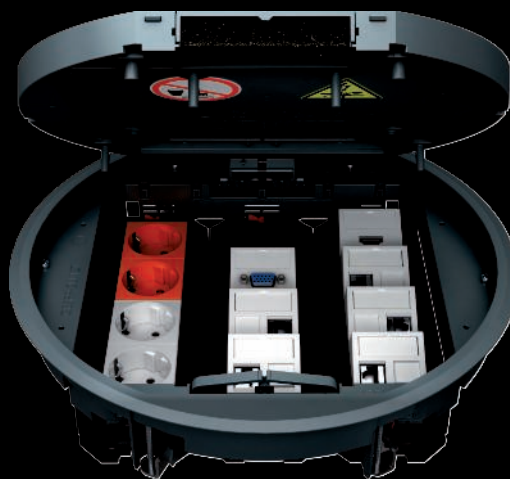

Floor covering depth

The recess for the floor covering in the cover of the outlets can be adjusted in stages to a floor covering depth of between 3 and 12 mm.

GRAF9

The solution for wet-cleaned floors: The GRAF9 service outlet is ideally suited for wet-cleaned floors. The GRAF9 is made completely of metal and offers a high load capacity. A variant is available with a ring-shaped structure in the lid surface, along with a variant with a 4 mm floor covering recess in the hinged cover.



High-quality materials

The floor covering protection frame and the hinged cover of the GRAF9 service outlet are made of die-cast aluminium. Its tube body is made from robust die-cast zinc.

08_UFS / en / 2019/07/18 10:39:53 (LLExpert_02500) / 2019/07/18 10:40:17 10:40:17

Wet care

The GRAF9 service outlet possesses seals in the cover and in the tube body. If the service outlet is opened for cable installation, the 10 mm-high tube body ring protects the electrical installation against the ingress of water. The GRAF9 service outlet with tube body thus fulfils the IP requirements for installation in wet-cleaned floors.



Loads

The service outlet can withstand extreme loads. When installed in a screed box with heavy-duty extension, installation in floor areas with increased load requirements is possible.

For more information, refer to the section on heavy-duty systems.



Practical tube body

The tube body is the cable outlet for wet-cleaned floors. With just a few actions, this can be opened for cable routing and can just as easily be lowered into the cover of the GRAF9 to be flush with the floor.

Compatible

Service outlets from Ackermann made by OBO are suitable for installation in underfloor duct and trunking systems, as well as in system floors. They are compatible with various underfloor systems, including the EÜK screed-covered system and the open OKA screed-flush system.

Screed-covered
duct system
EÜK

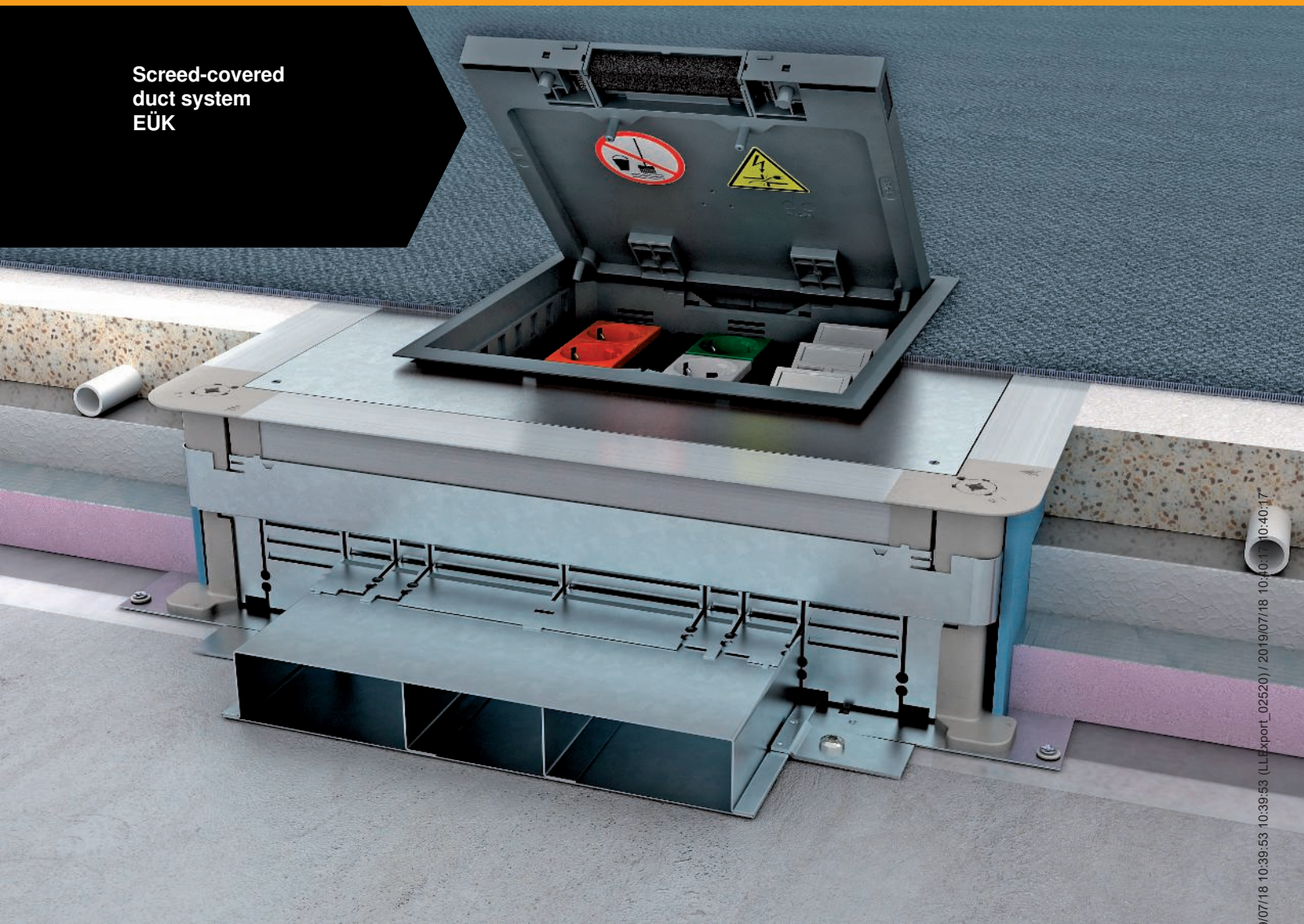

08_UFS / en / 2019/07/18 10:39:53 10:39:53 (LLEExport_02520) / 2019/07/18 10:40:17 10:40:17

Screed-flush
trunking system
OKA

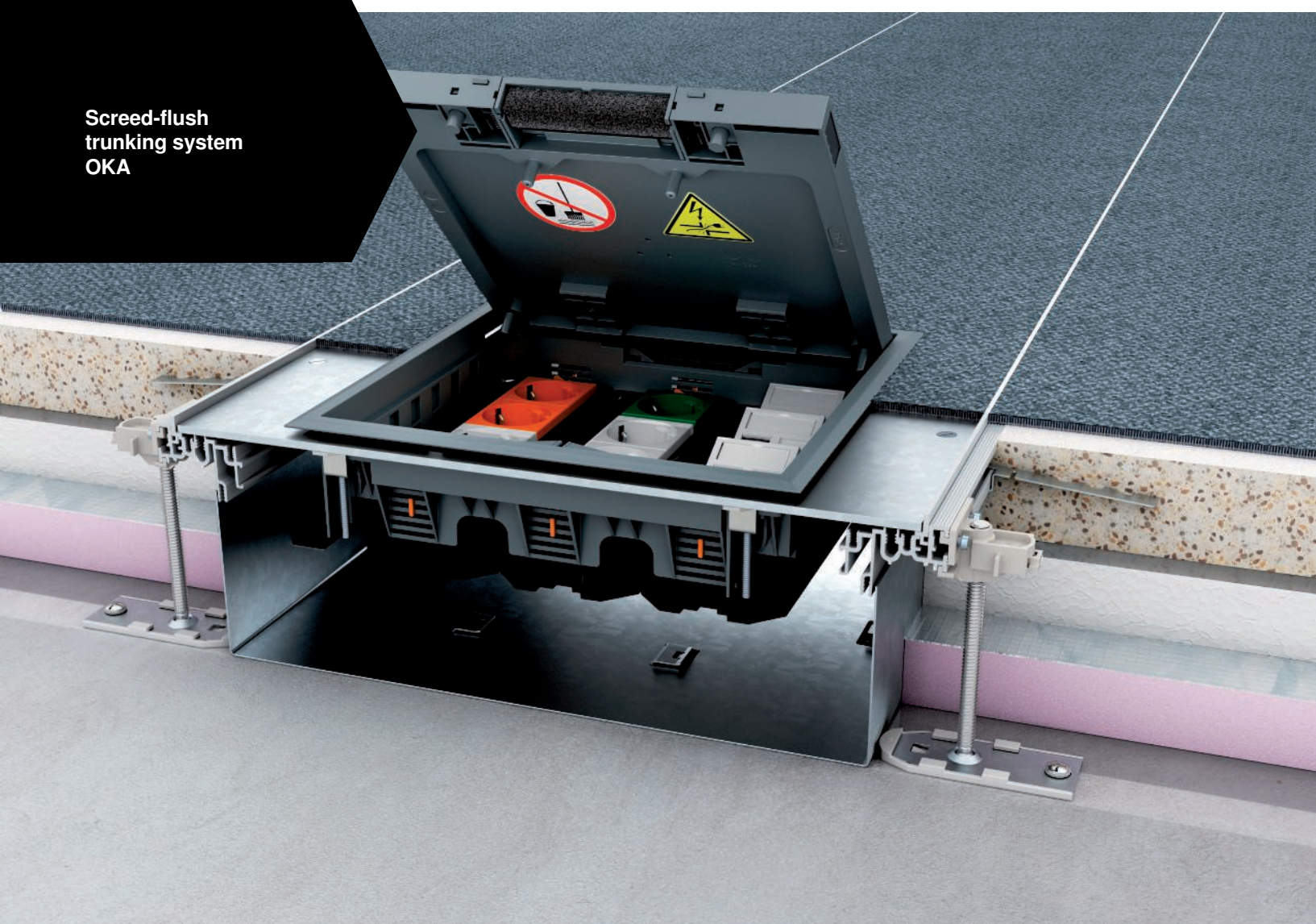

Raised and cavity floors



08_UFS / en / 2019/07/18 10:39:53 (LLEExport: 520) / 2019/07/18 10:39:53 17 10:40:17

Installation and floor cut-out dimensions

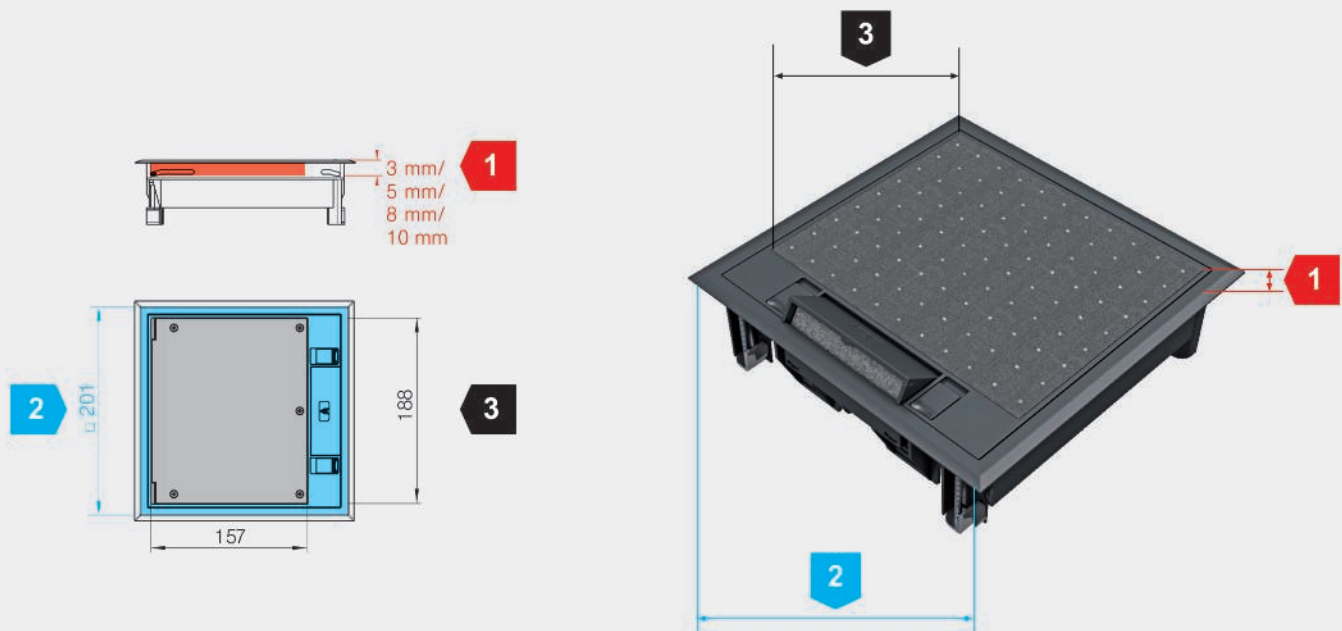

Various installation and floor cut-out dimensions must be taken into account for the mounting of service outlets and the application of floor coverings in the device lids.



Frame height for the floor covering in the lid (red dimensions)

The frame height data relates to the maximum floor covering thickness, including adhesive. If, in the figure, several heights are specified, then the frame height can be changed during construction: By adding or removing spaces, it is possible to adjust the desired frame height to the floor covering. In the as-delivered state, the frame height is usually 5 mm.



Floor cut-out for the installation of service outlets (blue dimensions)

The dimensions for the floor cut-out should be considered as target dimensions for correct installation of the service outlet in the floor. They are only generally required for the floor cut-out in system floors. When mounting service outlets in the EÜK screed-covered duct system or in the OKA open trunking system, they need not be taken into account, as these systems offer prefabricated mounting lids with matching installation openings.



3

Internal dimension of the lid to determine the floor covering cut-out (black dimensions)

The dimension data relates to the internal dimension of the lid and is used to calculate the floor covering cut-out. Depending on the type of floor covering, appropriate reductions should be taken into account, e.g. for expansion gaps.

4

Minimum floor structure height (raw concrete ceiling to finished floor)

The dimension describes the minimum floor structure height from the raw concrete ceiling to the top edge of the finished floor. It guarantees correct installation and use of installation devices, such as sockets, data and multimedia connections.

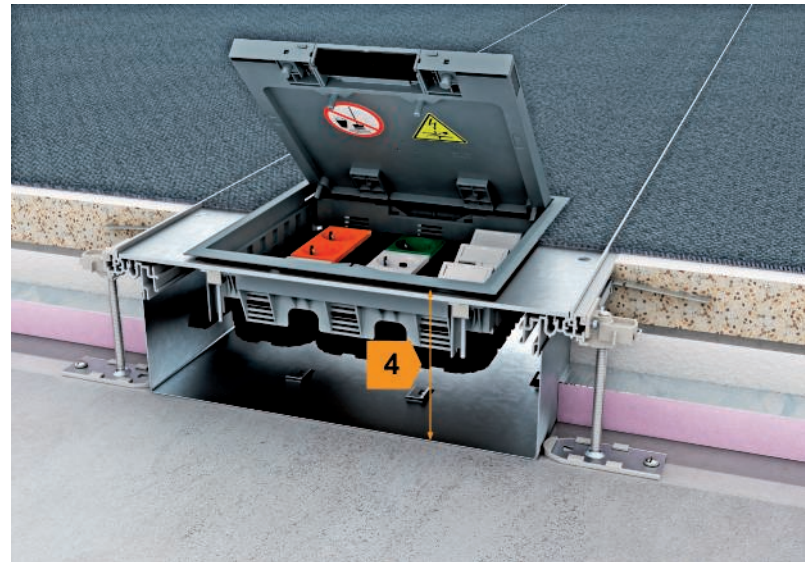

Minimum installation heights

Service outlet type	Frame height in the lid	Minimum floor structure height
GES2, GES4, GESR4, GESR9SR	5 mm	73 mm
GES4-2, GES6-2, GES9-3B, GES9-3S	5 mm	73 mm
GES4-2, GES6-2, GES9-3B, GES9-3S	10 mm	78 mm
GES6, GESR9	5 mm	73 mm
GESR7, GESRA7, GESRA9, GESR9/10	5 or 10 mm	78 mm
GES4M-2, GES6M-2, GES9M-2	5 or 10 mm	78 mm
GESR9-2	5 or 10 mm	76 mm
GRAF9	-	80 mm

System measurements service outlets, rectangular

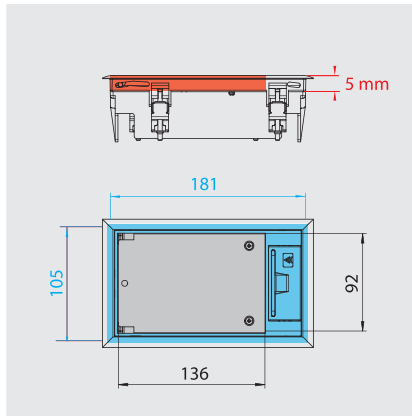

Nominal size 2, type GES2

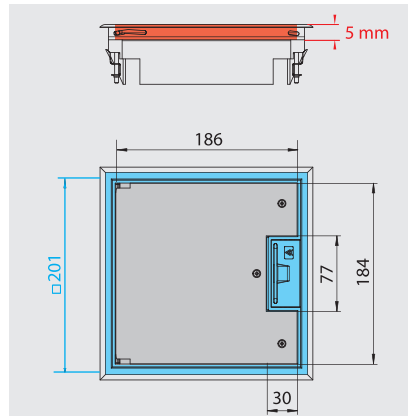

Nominal size 4, type GES4

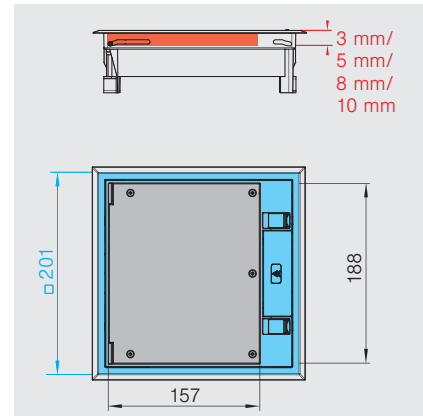

Nominal size 4, type GES4-2

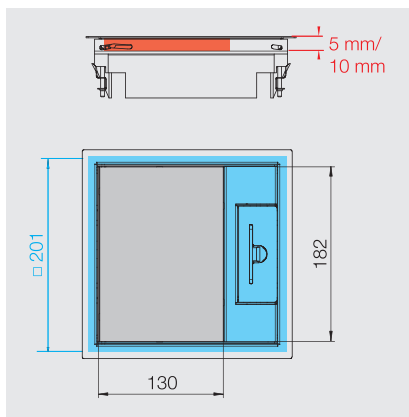

Nominal size 4, type GES4M-2

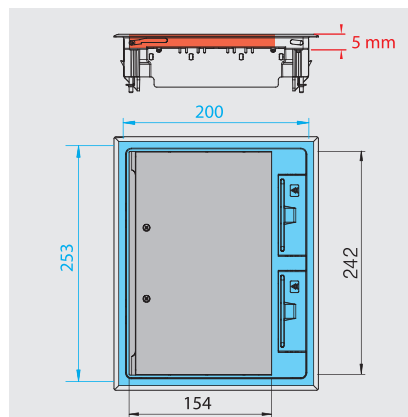

Nominal size 6, type GES6

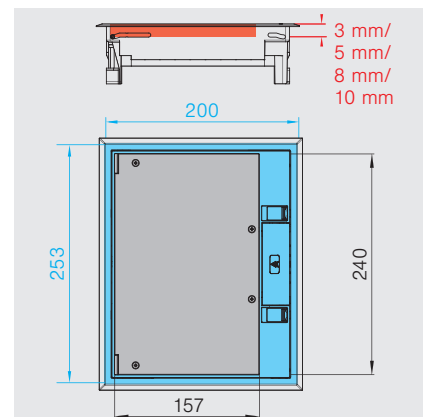

Nominal size 6, type GES6-2

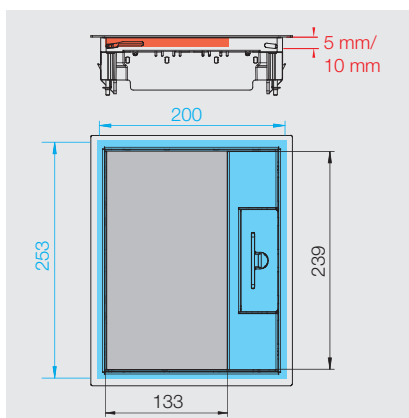

Nominal size 6, type GES6M-2

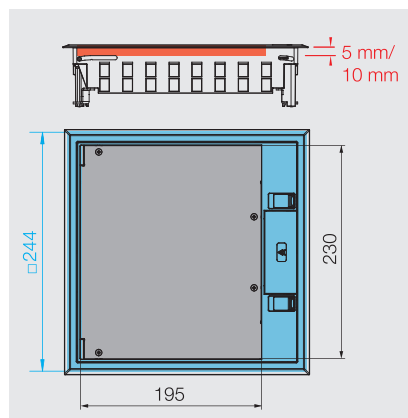

Nominal size 9, type GES9-3S and GES9-3B

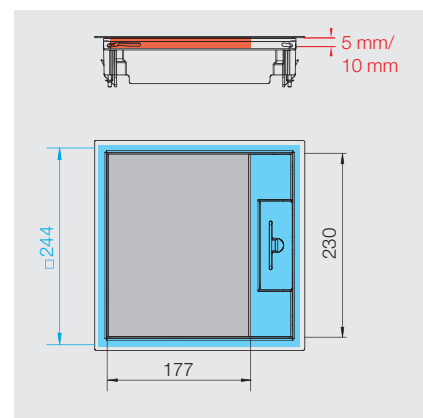

Nominal size 9, type GES9M-2

System measurements service outlets, round

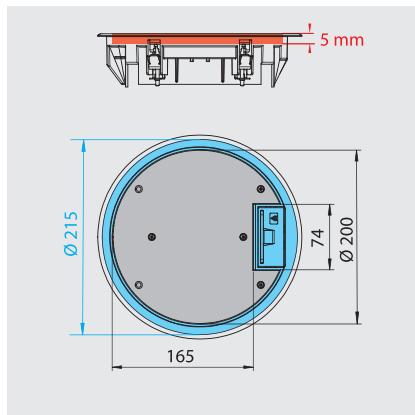

Nominal size R4, type GESR4

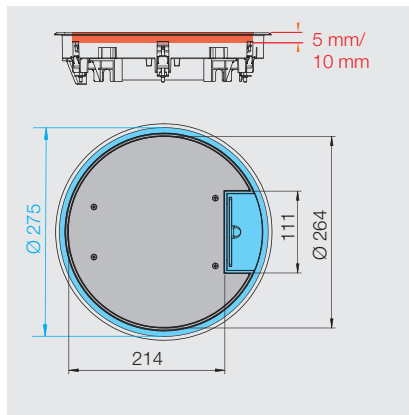

Nominal size R7, type GESR7

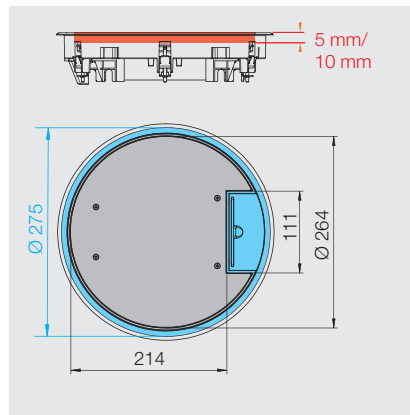

Nominal size R7, type GESRA7

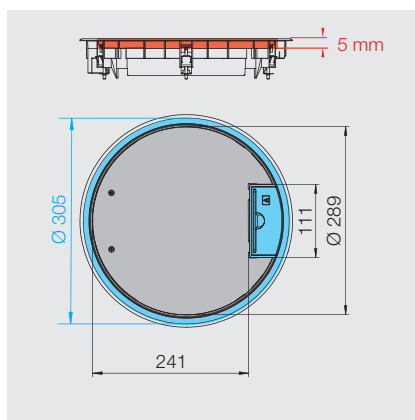

Nominal size R9, type GESR9

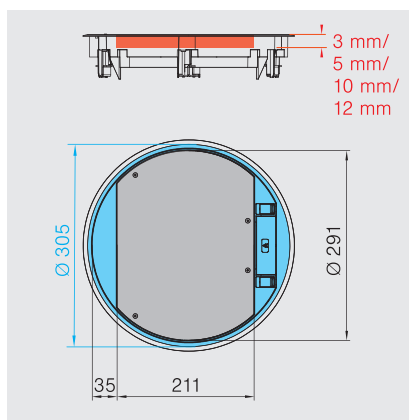

Nominal size R9, type GESR9-2

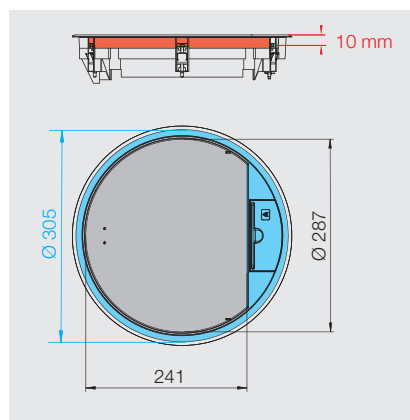

Nominal size R9, type GESRA9

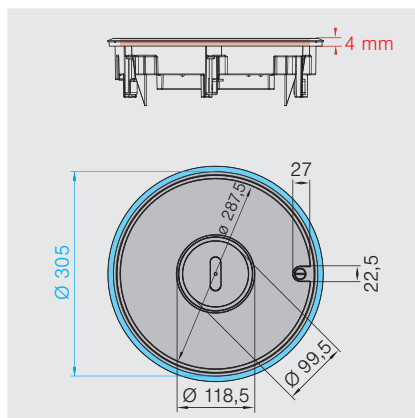

Nominal size R9, type GRAF9-2
BA

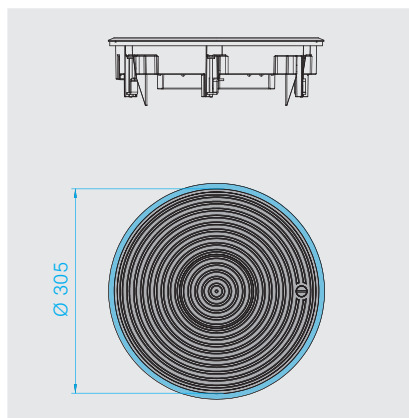

Nominal size R9, type GRAF9-2

Installation principle, rectangular and round service outlet

System components

1	Service outlet, rectangular
2	Service outlet, round
3	Universal supports
4	Cover plates
5	Mounting support

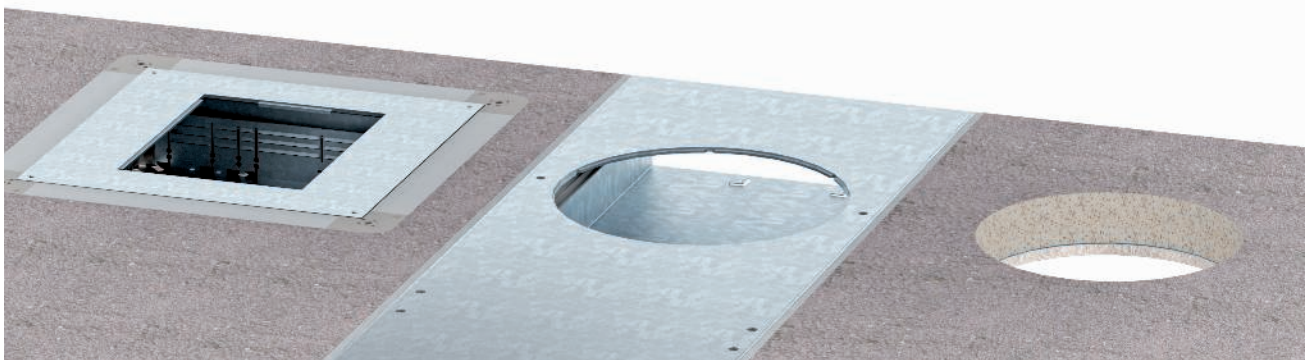
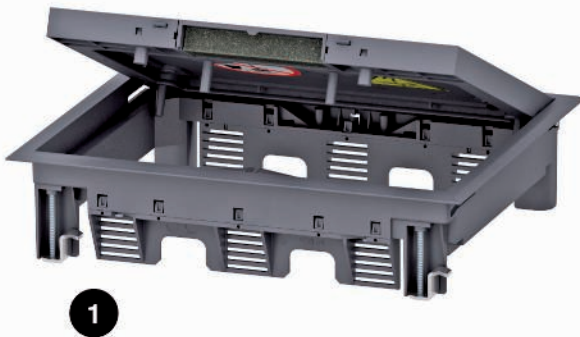
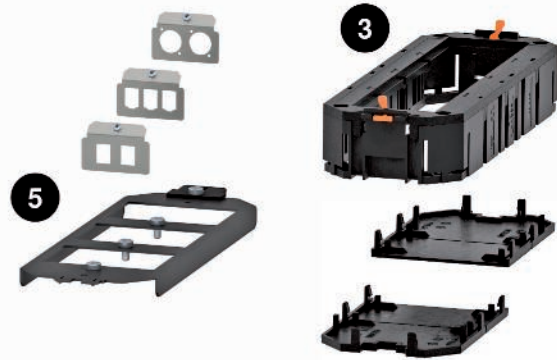

Installation principle, wet-cleaned service outlet

System components

1	Underfloor junction and branch box
2	Heavy-duty lid support
3	Mounting lid
4	Heavy-duty mounting lid
5	GRAF9-2 service outlet
6	Universal support
7	Cover plate
8	Mounting support

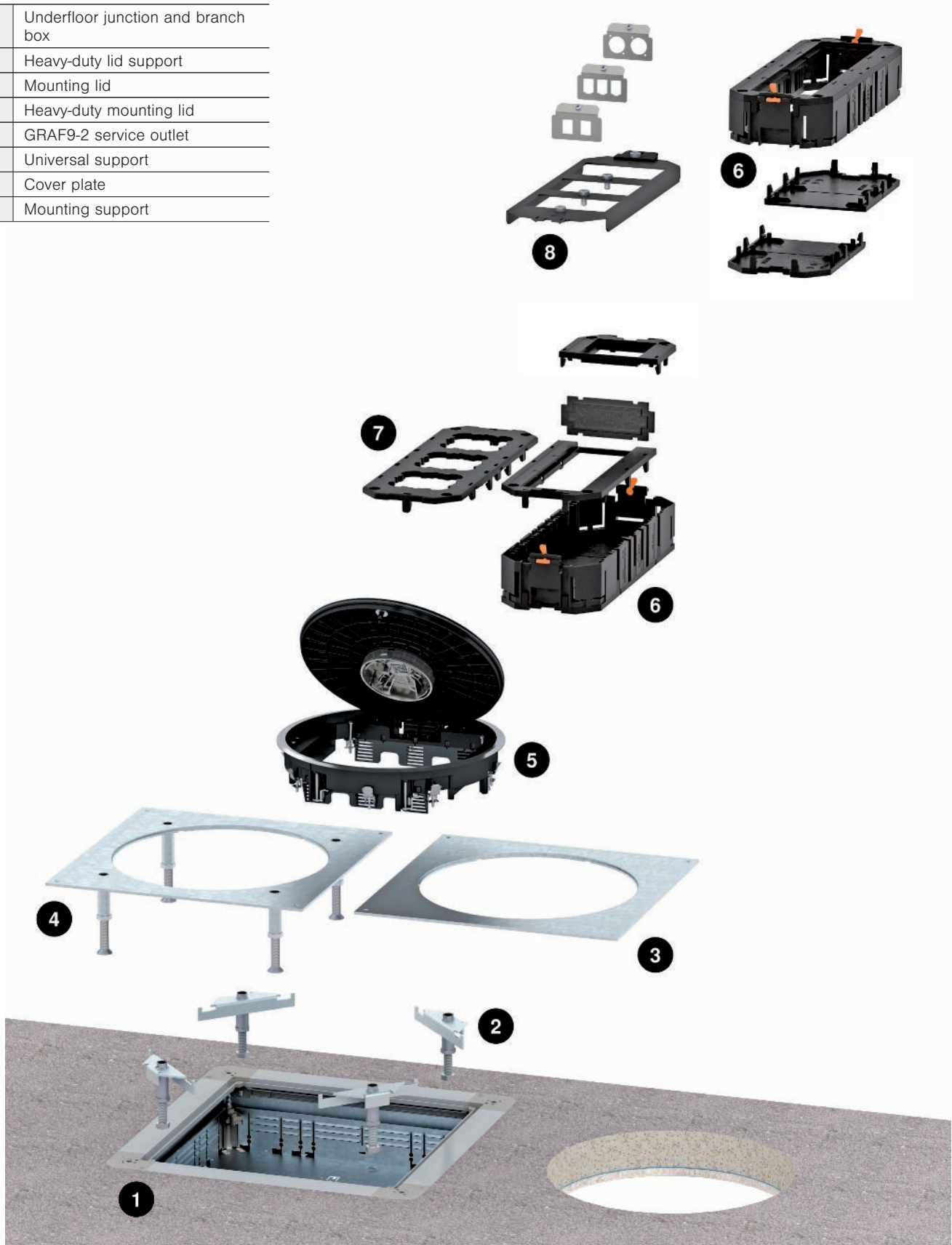

Standard data

To DIN EN 50085-1 and DIN EN 50085-2-2

Class		Service outlets type GES	GRAF9 service outlet
6.2	According to impact resistance for installation and application		
6.2.4	Electrical installation duct systems for impact energy 5 J	5 J	5 J
6.3	According to temperatures, as specified in Tables 1, 2 and 3		
Table 1	Minimum storage and transport temperature ± 2 °C	-15 °C	-15 °C
Table 2	Minimum installation and application temperatures ± 2 °C	+5 °C	+5 °C
Table 3	Application temperatures ± 2 °C	+60 °C	+60 °C
6.4	According to the resistance against fire spread		
6.4.1	Electrical installation duct systems which permit the spread of fire	x	x
6.5	According to the electrical conductivity		
6.5.1	Electrical installation duct systems with electrical conductivity	x ¹	x
6.5.2	Electrical installation duct systems without electrical conductivity	x ²	
6.6	According to the electrical insulation property		
6.6.1	Electrical installation duct systems with electrical insulation capability	x ²	
6.6.2	Electrical installation duct systems without electrical insulation capability	x ¹	x
6.7	According to the protection ratings offered by the housing or casing to EN 60529:1991		
6.7.1	According to protection against ingress of solid foreign bodies	x	x
6.7.3	According to protection against contact with dangerous parts	x	x
6.101	Depending on the type of floor care		
6.101.1	Electrical installation duct systems for dry floor cleaning	x	
6.101.2	Electrical installation duct systems for wet floor cleaning when the service outlet is not in use		x
6.101.3	Electrical installation duct systems for wet floor cleaning when the service outlet is in use		x
6.102	According to resistance to vertical loads affecting a small surface area		
6.102.5	Electrical installation duct systems for 2,000 N	x ²	
6.102.7	Electrical installation duct systems for 3,000 N	x ¹	x
6.103	According to resistance to vertical loads affecting a large surface area		
6.103.2	Electrical installation duct systems for 3,000 N	x ²	
6.103.3	Electrical installation duct systems for 5,000 N	x ¹	
6.103.4	Electrical installation duct systems for 10,000 N		x

¹Applies to metallic GES, ² applies to polyamide GES



Planning checklist

When selecting underfloor systems with service outlets, the following planning criteria, amongst others, should be taken into account:

- ✓ Take the type of floor covering into account. With wet-cleaned floors, insert a service outlet with tube body
- ✓ Select the size of the service outlet according to the number of installation units
- ✓ Observe the minimum installation depth for the installation of sockets and data/multimedia connections
- ✓ Plastic service outlets are designed for normal loads in office and administration buildings. At increased load requirements, use metallic service outlets
- ✓ Apply the floor covering in the service outlet lid taking height adjustment and expansion joints into account



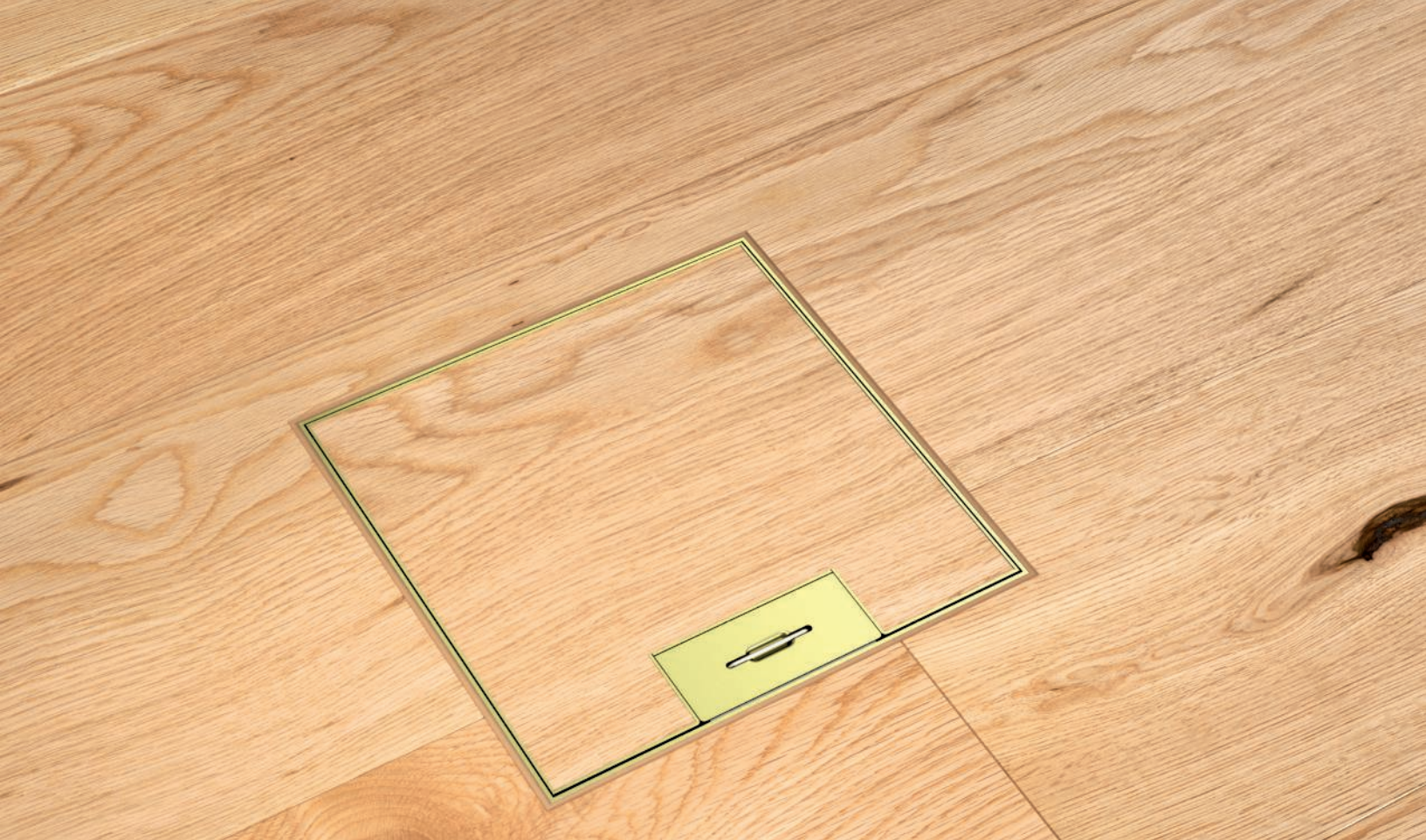

Cassettes – height-adjustable and decouplable

The compact, flush-floor cassettes from Ackermann made by OBO provide power, data and multimedia connections in a high-quality design. The cassettes can be adjusted to the height of the floor and can be installed completely decoupled as a special construction type. They are available in round and rectangular versions. There are versions for dry, moist and wet-care floor coverings. Cassettes are suitable for raised and cavity floors and all kinds of screed-flush under-floor systems.



Stable and long-life

Height-adjustable cassettes are frequently used in natural stone floors and tiled floors. Here, stability and a long lifespan are required. The cassettes from Ackermann made by OBO stand out through their well-thought-out functions and high-quality materials.



That's what we call variety.

Round or rectangular? For dry and wet-cleaned floors? Height-adjustable? Decouplable? There are a wide range of selection options for the cassettes.

Three lid variants are available: With blanking lid, with cord outlet or with tube body. The rectangular are available in the nominal sizes 4 and 9 and the round versions are available in the nominal sizes R4, R7 and R9.



Nominal size 4 with blanking lid
External dimension 199 x 199 mm
6 x Modul 45



Nominal size 4 for tube body
External dimension 199 x 199 mm
6 x Modul 45



Nominal size 4 with cord outlet
External dimension 199 x 199 mm
6 x Modul 45

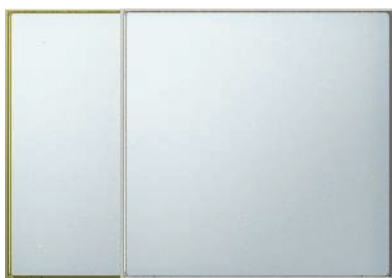

Nominal size 9 with blanking lid
External dimension 243 x 243 mm
12 x Modul 45



Nominal size 9 for tube body
External dimension 243 x 243 mm
12 x Modul 45



Nominal size 9 with cord outlet
External dimension 243 x 243 mm
12 x Modul 45



Nominal size R4 with blanking lid
External dimension \varnothing 214 mm
6 x Modul 45



Nominal size R4 for tube body
External dimension \varnothing 214 mm
6 x Modul 45

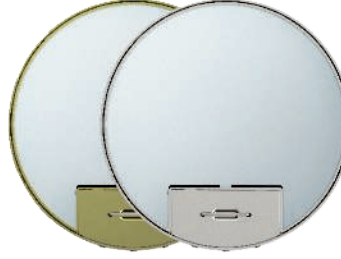

Nominal size R4 with cord outlet
External dimension \varnothing 214 mm
6 x Modul 45

The cassette components visible in the floor covering are made from stainless steel or brass. There are versions for floor covering thicknesses of 20 mm and 25 mm.



Nominal size R7 with blanking lid
External dimension Ø 274 mm
10 x Modul 45

Nominal size R7 for tube body
External dimension Ø 274 mm
10 x Modul 45

Nominal size R7 with cord outlet
External dimension Ø 274 mm
10 x Modul 45



Nominal size R9 with blanking lid
External dimension Ø 304 mm
12 x Modul 45

Nominal size R9 for tube body
External dimension Ø 304 mm
12 x Modul 45

Nominal size R9 with cord outlet
External dimension Ø 304 mm
12 x Modul 45



The cassettes can be equipped with three different tube body variants: With cover plate, with cover plate and handle clamp or with floor covering recess and handle clamp.

Cassette types

Height-adjustable cassettes

The height-adjustable cassettes can be adjusted exactly to the top edge of the floor covering. The cassettes can be installed inside underfloor duct systems in a screed box or in system floors, as shown below. They are fastened to the raw concrete using height-adjustment units.

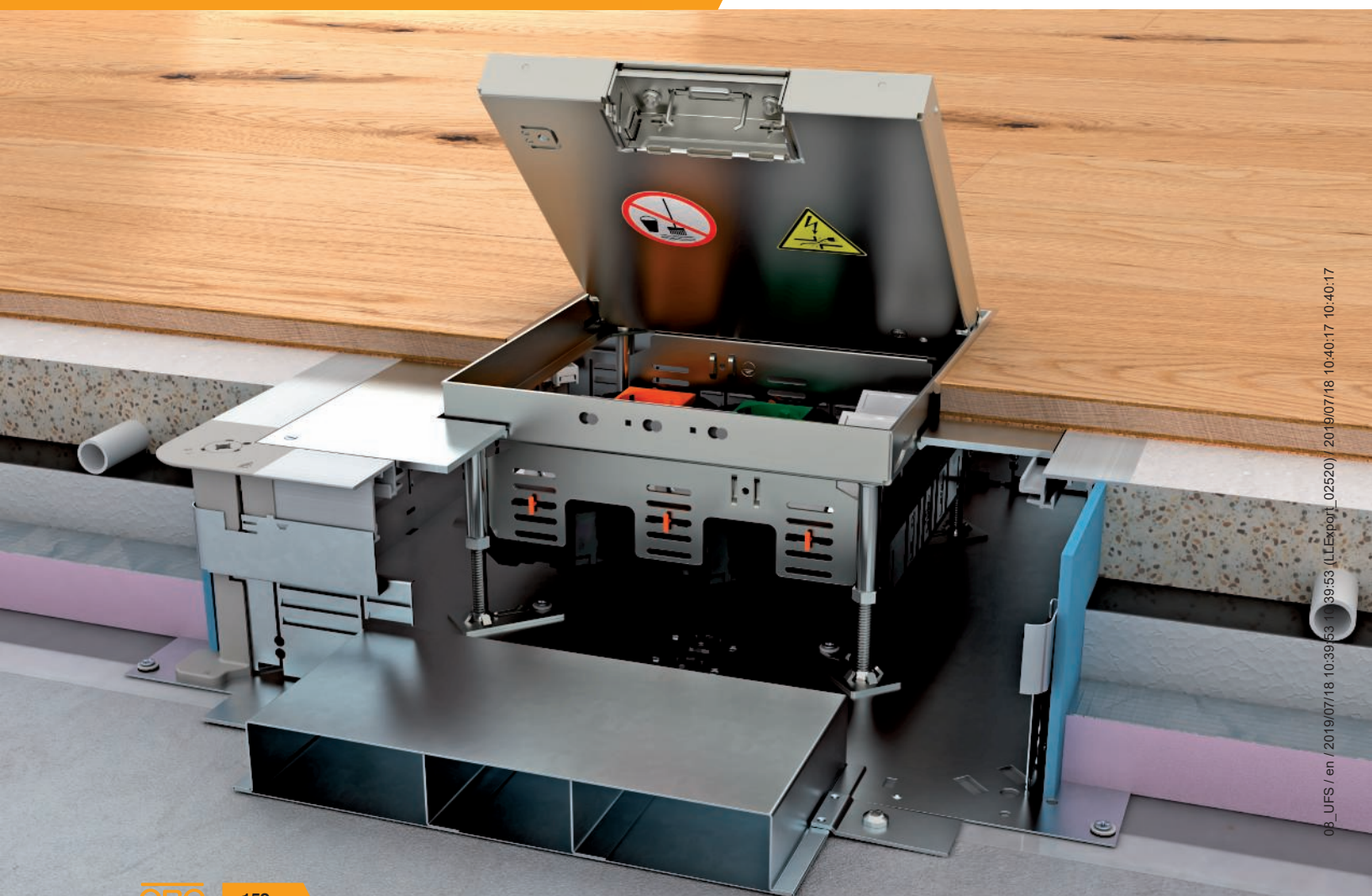
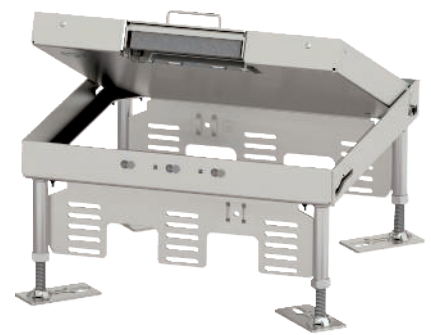

08_UFS / en / 2019/07/18 10:39:53 (LLExport_02520) / 2019/07/18 10:40:17 10:40:17

Height-adjustable, decouplable cassettes

The height-adjustable, decouplable cassettes are not fixed on the raw concrete, but are fixed in underfloor - boxes using height-adjustment brackets. In the installation example shown, the cassette is adjusted to the top edge of the finished floor using height-adjustment brackets, located in the socket top frame of the underfloor box. This prevents the transmission of footfall sound.

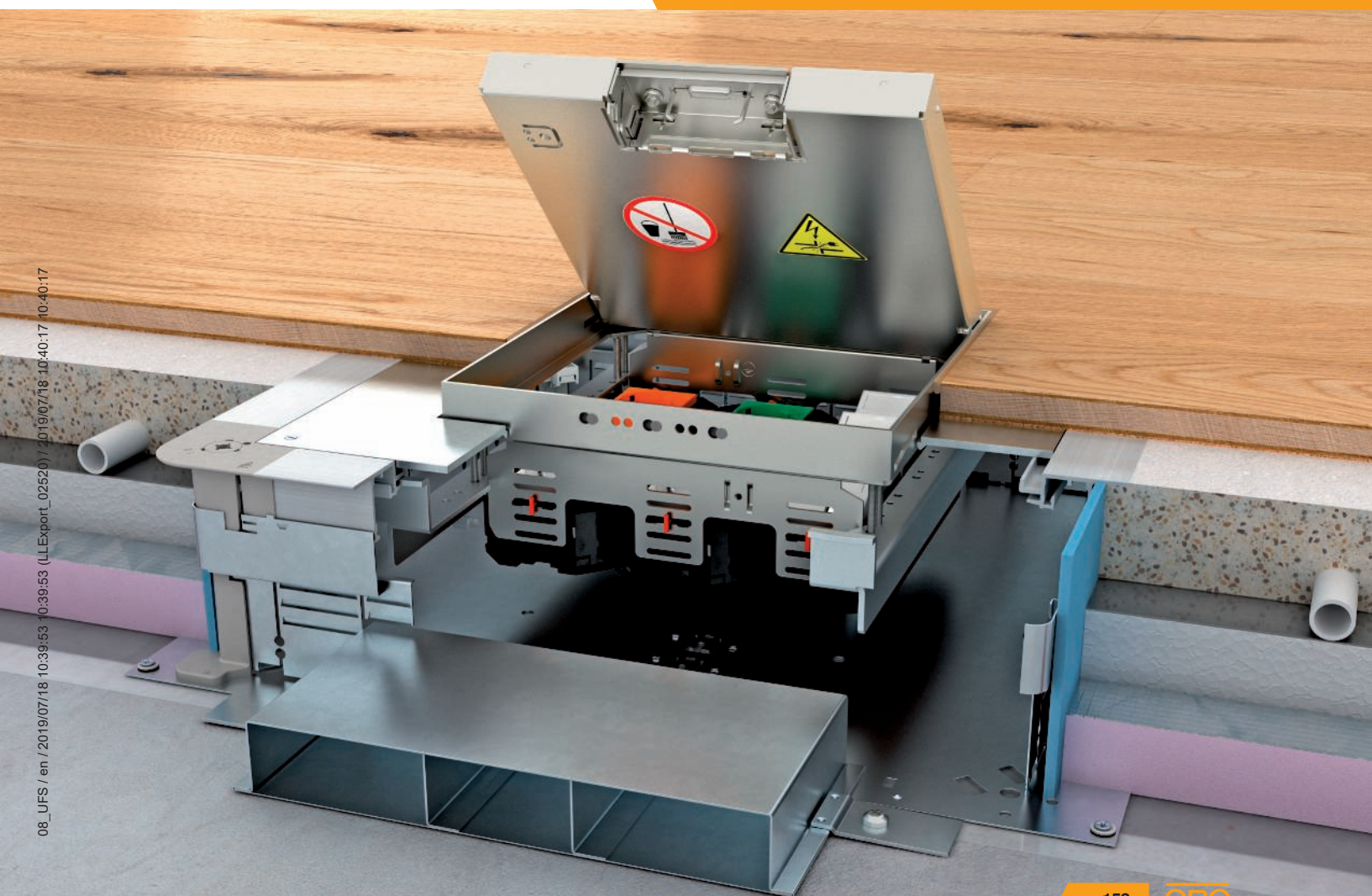
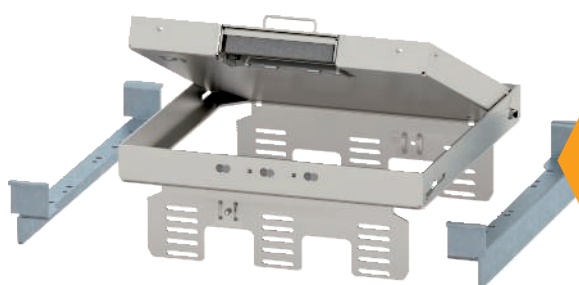

Cassettes with cord outlet

Cassettes with brass and stainless steel cord outlets are the ideal solution for dry and moist-cleaned floors, such as wooden planks or parquet.

Practical details

The integrated equipotential bonding guarantees the conductive connection between the cassette lid and frame.

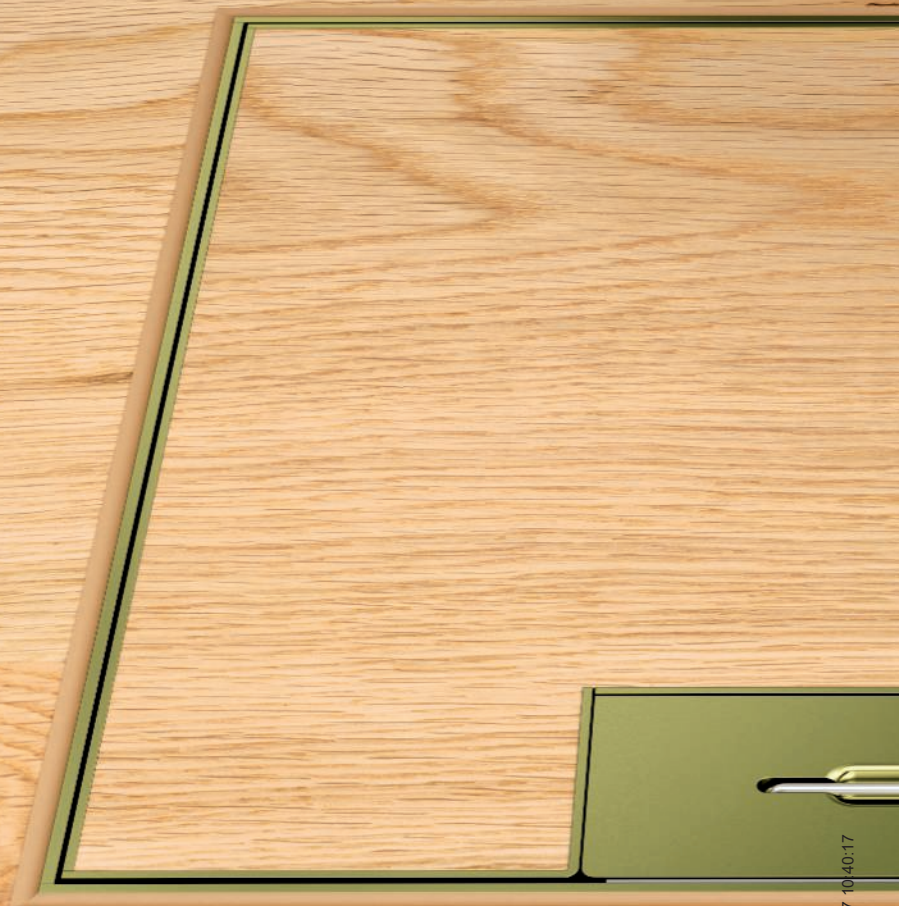

Loads

The cassette frames are made from high-quality stainless steel or brass. An integrated, 4 mm-thick sheet steel plate also increases the load capacity of the cassettes. They are tested according to the standard EN 50085-2-2 in the highly modern testing systems of the company's own BET Test Centre.



Swivellable cord outlet

The models have a swivelling cord outlet which protects the cable exit in dry and moist-cleaned floors.

Highest quality, even when wet

The cassettes with tube body are suitable for wet-cleaned floors. The tube body opening also offers the option of passing through large-volume connector systems, such as CEE connectors.

High-quality materials



The visible components of the tube cassettes are made of stainless steel. This means that the cassettes have a fine appearance and, at the same time, are resistant to cleaning agents.

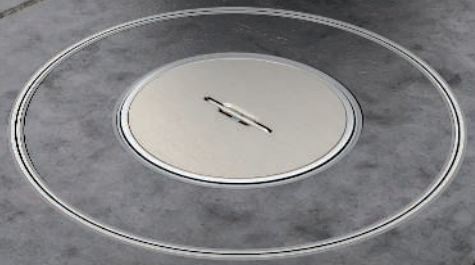

Practical tube body

The tube body can be opened for cable routing with just a few actions and can just as easily be lowered to be flush with the floor. Three variants are available: With cover plate, with cover plate and handle clamp or with floor covering recess and handle clamp.



Wet care

The tube body cassette possesses seals in the lid and in the tube body. If the service outlet is opened for cable installation, the 10 mm-high tube body ring protects the electrical installation against the ingress of water. The tube body cassettes thus fulfil the IP requirements for installation in wet-cleaned floors.



Compatible

Cassettes from Ackermann made by OBO are suitable for installation in underfloor duct systems, as well as in system floors. They are compatible with various underfloor systems, including the EÜK screed-covered system and the open OKA screed-flush system.

Screed-covered
duct system
EÜK



08_UFS / en / 2019/07/18 10:39:53 10:39:53 (LLEExport_02520) / 2019/07/18 10:40:17 10:40:17



Raised and cavity floors



08_UFS / en / 2019/07/18 10:39:53 (LLExpert 2520) / 2019/07/18 10:40:17 10:40:17

Fine polishing – underfloor system for polished screeds



Tube body and cassettes with hinged cord outlet

The cassettes with a tube body lid are suitable for classic wet cleaning: The tube body protects the installation compartment against ingressing water. The cassettes were tested according EN 50085-2-2 for use in wet-cleaned floors. The requirements of the standard are also fulfilled when the tube body is opened to let out cables. Cassettes with folding cord outlets are suitable for dry floor cleaning or for moistened floor cleaning with a wrung mop.



Jointless installation of cassettes

Jointless floor areas, such as polished cement or poured asphalt screeds, are the latest trend in modern interior architecture. Architects and customers value this type of floor covering design for its varied design options and its economy.

Ackermann made by OBO can offer a special underfloor solution in order to integrate access points to the electrical installation into the floor area without joints: The cassette lined body for polished screeds.





Poured asphalt screed and cement screed

The components of the cassette lined bodies are made from robust metal. The hot poured asphalt screed can therefore be worked directly onto the cassette frame and the cassette lined body. Poured asphalt screed is used where there are high requirements for heat protection, noise insulation and the elasticity of the floor covering. This screed type does not require drying times: The floor is ready for use shortly after laying. In addition, the under-floor solutions for polished screed floors can also be used in cement screeds. If cement screeds are polished multiple times, jointless floor areas with aggregate are created. One variant of this screed type is the Terrazzo floor.



Cassette lined body

The cassette lined body for polished screeds is designed in such a way that cassettes are integrated into the floor without gaps. The floor covering recess of the cassette cover is filled with a Terrazzo layer, which is specially polished together with suitable tools. This avoids unattractive joints. In this way, the access points to the electrical installations in the floor can be given an attractive appearance.

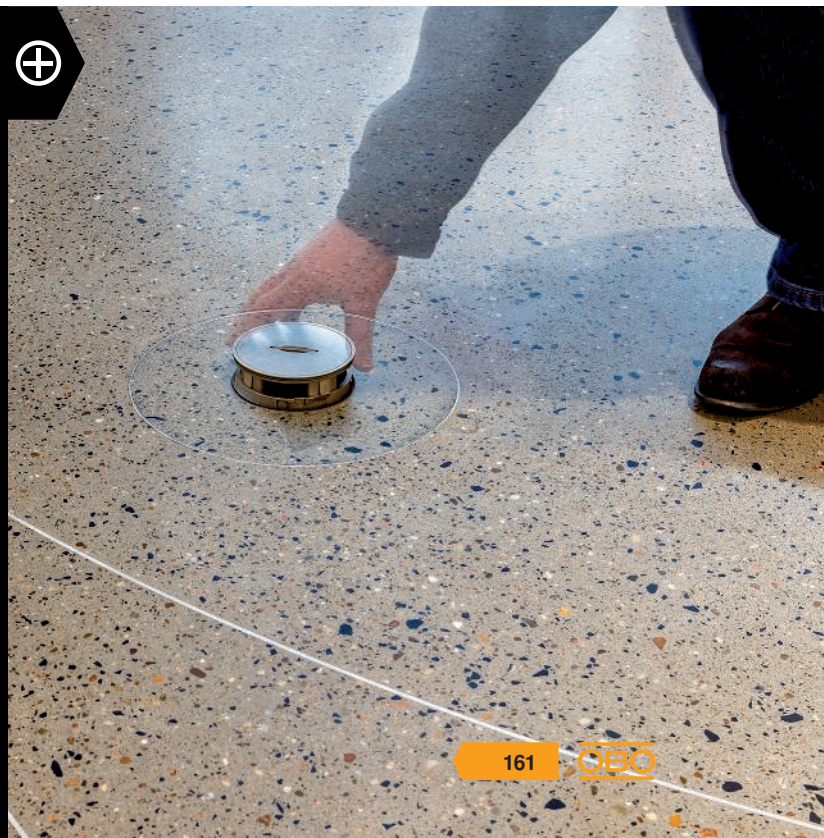

Installation and floor cut-out dimensions



Various installation and floor cut-out dimensions must be taken into account for the mounting of height-adjustable cassettes and the application of floor coverings in the cassette lids.

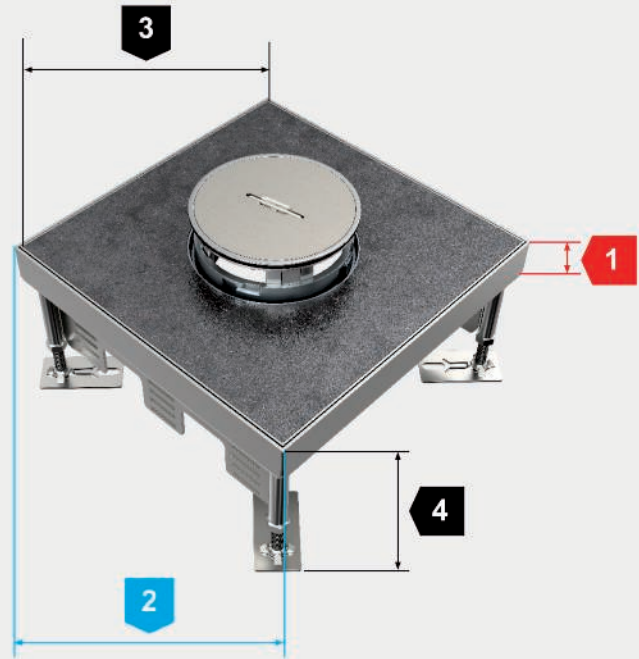
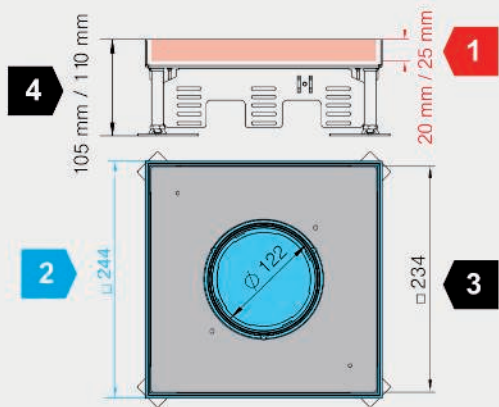

1

Frame height for the floor covering in the lid (red dimensions)

The frame height data relates to the maximum floor covering thickness, including adhesive. The cassettes are available in various frame heights.

2

Floor cut-out for the installation of cassettes (blue dimensions)

The dimensions for the floor cut-out should be considered as target dimensions for correct installation of the cassette in the floor. They are only generally required for the floor cut-out in system floors. The EÜK screed-covered duct system or the OKA open trunking system offer prefabricated mounting lids with matching installation openings.

3

Internal dimension of the lid to determine the floor covering cut-out (black dimensions)

The dimension data relates to the internal dimension of the cassette lid and is used to calculate the floor covering cut-out. Depending on the type of floor covering, appropriate reductions should be taken into account, e.g. for expansion gaps.

4

Minimum floor structure height (raw concrete ceiling to finished floor)

The dimension describes the minimum floor structure height from the raw concrete ceiling to the top edge of the finished floor. It guarantees correct installation and use of installation devices, such as sockets, data and multimedia connections.

System dimensions, height-adjustable square cassettes

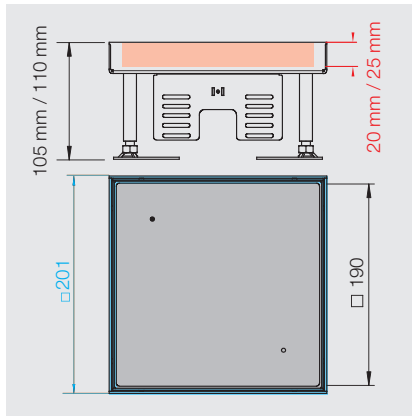

Nominal size 4, type RKN2

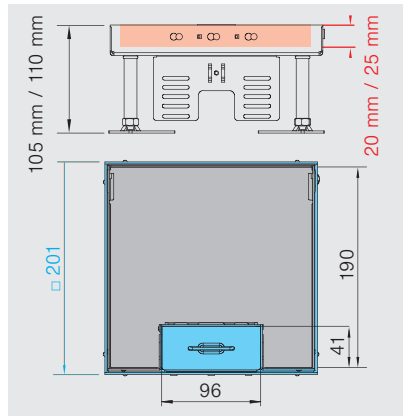

Nominal size 4, type RKS2

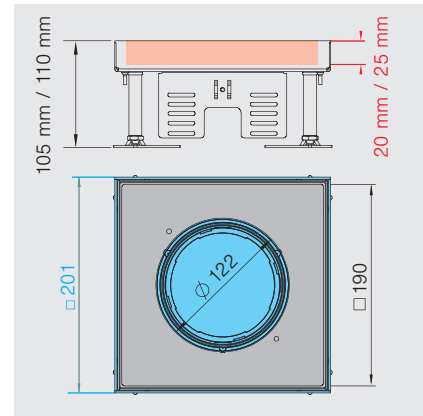

Nominal size 4, type RKF2

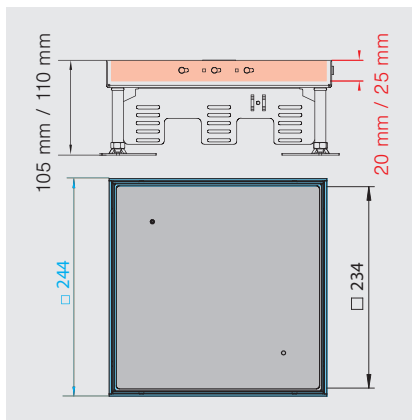

Nominal size 9, type RKN2

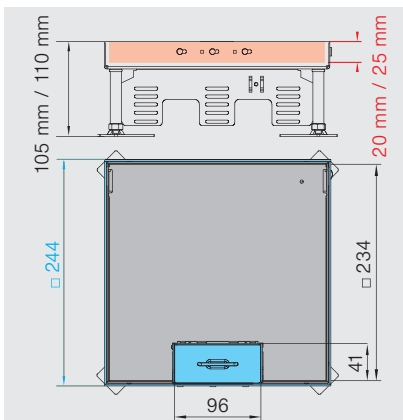

Nominal size 9, type RKS2

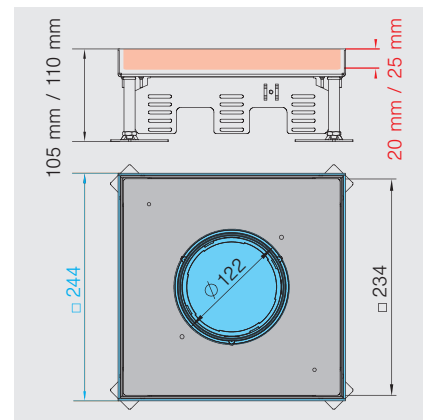

Nominal size 9, type RKF2

System dimensions, height-adjustable round cassettes

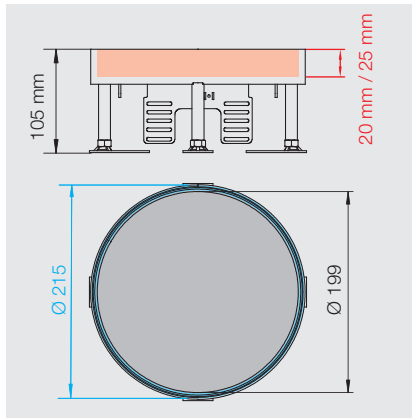

Nominal size R4, type RKR2 and RKRN2

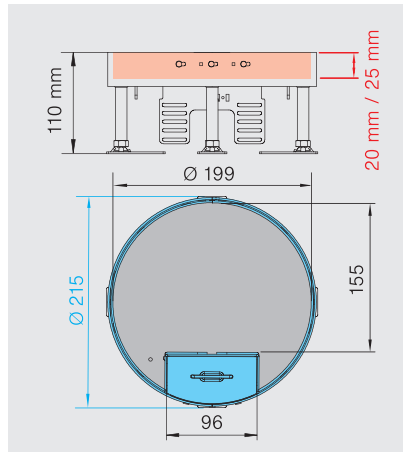

Nominal size R4, type RKS2 and RKSRN2

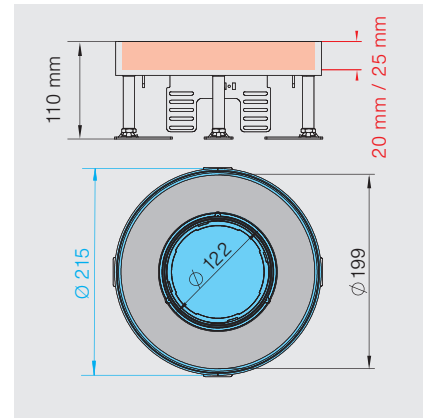

Nominal size R4, type RKFR2 and RKFRN2

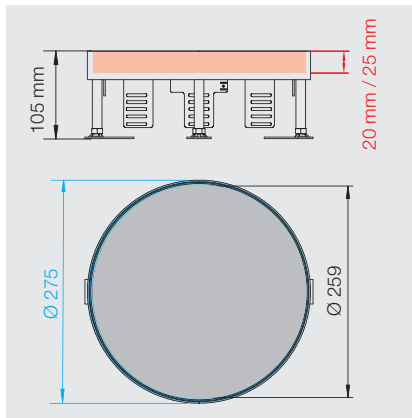

Nominal size R7, type RKR2 and RKRN2

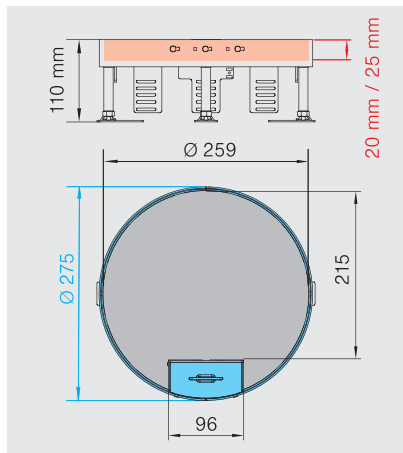

Nominal size R7, type RKS2 and RKSRN2

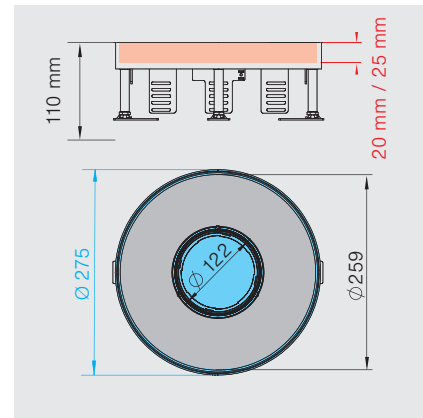

Nominal size R7, type RKFR2 and RKFRN2

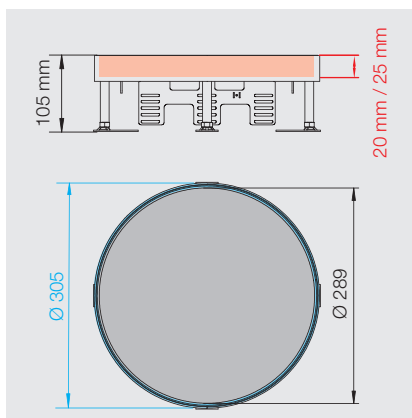

Nominal size R9, type RKR2 and RKRN2

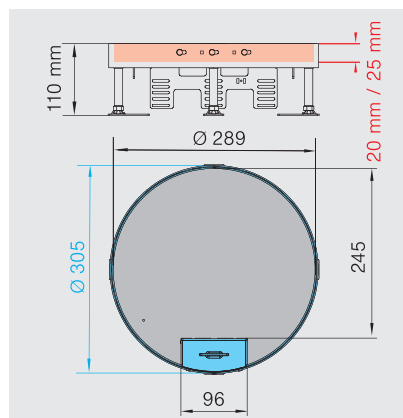

Nominal size R9, type RKS2 and RKSRN2

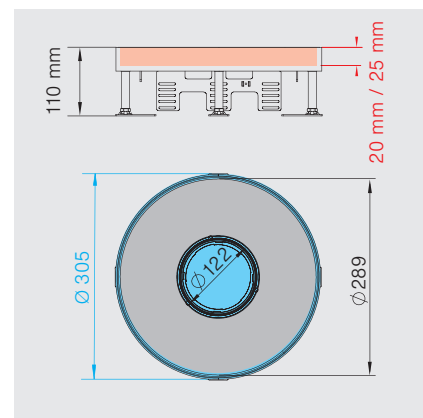

Nominal size R9, type RKFR2 and RKFRN2

Installation principle, height-adjustable square cassette

System components

1	Height-adjustable square cassette with cord outlet
2	Height-adjustment bracket
3	Height-adjustable and decouplable square cassette
4	Cassette for tube body
5	Tube body
6	Cassette for inspection opening
7	Threaded sleeve

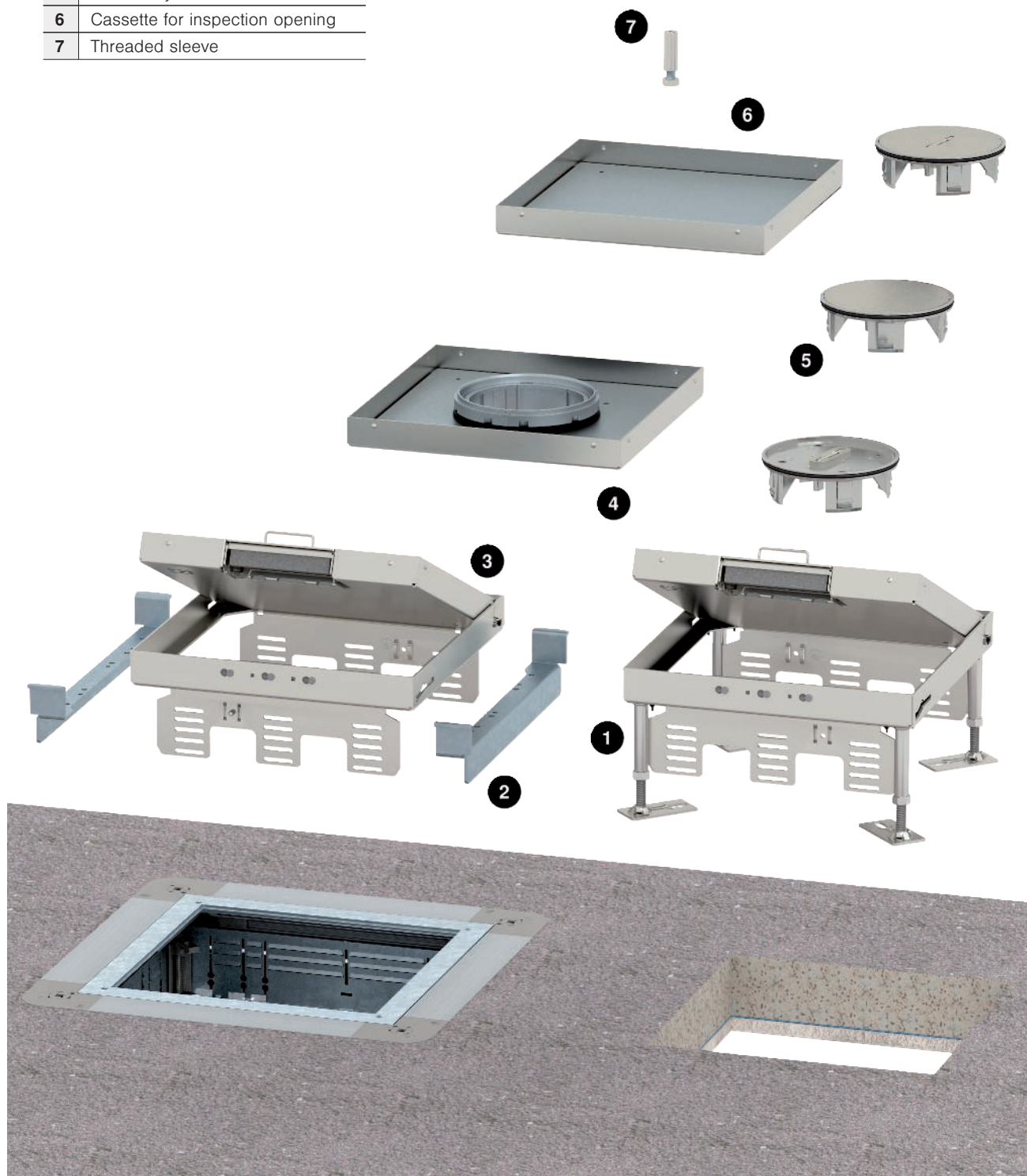

Installation principle, height-adjustable round cassette

System components

1	Height-adjustable round cassette with cord outlet
2	Height-adjustment bracket
3	Height-adjustable and decouplable round cassette with cord outlet
4	Cassette for tube body
5	Tube body
6	Cassette for inspection opening
7	Threaded sleeve

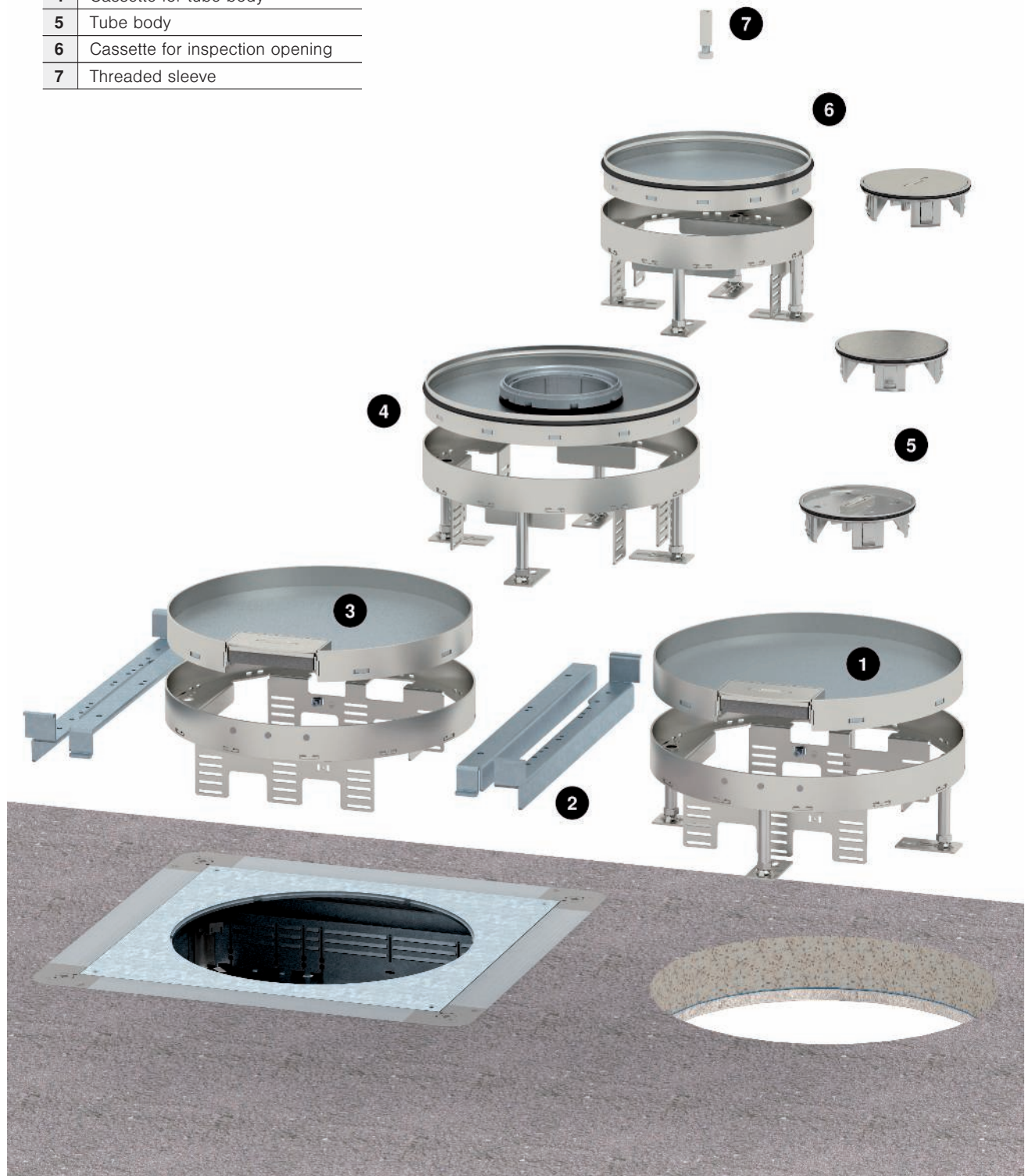

Standard data

To DIN EN 50085-1 and DIN EN 50085-2-2

Class		Height-adjustable cassettes
6.2	According to impact resistance for installation and application	
6.2.4	Electrical installation duct systems for impact energy 5 J	5 J
6.3	According to temperatures, as specified in Tables 1, 2 and 3	
Table 1	Minimum storage and transport temperature ± 2 °C	-25 °C
Table 2	Minimum installation and application temperatures ± 2 °C	+5 °C
Table 3	Application temperatures ± 2 °C	+60 °C
6.4	According to the resistance against fire spread	
6.4.2	Electrical installation duct systems which do not permit the spread of fire	x
6.5	According to the electrical conductivity	
6.5.1	Electrical installation duct systems with electrical conductivity	x
6.6	According to the electrical insulation property	
6.6.2	Electrical installation duct systems without electrical insulation capability	x
6.7	According to the protection ratings offered by the housing or casing to EN 60529:1991	
6.7.1	According to protection against ingress of solid foreign bodies	x
6.7.2	According to protection against ingress of water	x
6.101	Depending on the type of floor care	
6.101.1	Electrical installation duct systems for dry floor cleaning	x ¹
6.101.2	Electrical installation duct systems for wet floor cleaning when the service outlet is not in use	x ²
6.101.3	Electrical installation duct systems for wet floor cleaning when the service outlet is in use	x ²
6.102	According to resistance to vertical loads affecting a small surface area	
6.102.7	Electrical installation duct systems for 3,000 N	x
6.103	According to resistance to vertical loads affecting a large surface area	
6.103.2	Electrical installation duct systems for 3,000 N	x
6.103.3	Electrical installation duct systems for 5,000 N	x ¹

x¹: Applies to cassettes with cord outlet, x²: Applies to cassettes with tube body and blanking lid



Planning checklist

When selecting underfloor systems with cassettes, the following planning criteria, amongst others, should be taken into account:

- ✓ Take the type of floor covering into account. With wet-cleaned floors, insert a cassette with tube body
- ✓ Select the size of the cassettes according to the number of installation units
- ✓ Observe the minimum installation depth of the height-adjustable cassettes
- ✓ Height-adjustable cassettes are designed for normal loads in office and administrative buildings. With increased load requirements, use stainless steel heavy-duty cassettes
- ✓ Apply the floor covering in the cassette lid taking height adjustment and expansion joints into account



Heavy-duty systems

Heavy-duty systems reliably supply areas with high load requirements with power, data and multimedia technology via the floor. Car dealerships, museums, airports, stations or hotels are typical areas of application. The construction and the material thickness is specially matched to the high load requirements. With the heavy-duty system, Ackermann made by OBO guarantees a particularly robust, safe and long-lasting installation solution.



Heavy-duty competence

Ackermann made by OBO has developed the special heavy-duty solutions for underfloor installations in close consultation with planners and architects. Standard products, such as the EÜK screed-covered duct system or the height-adjustable cassettes, form the basis of the development.

An internal company testing standard ensures the highest quality and the highest load capacity: Its requirements go beyond the requirements of DIN EN 50085-2-2. The comprehensive heavy-duty system from Ackermann made by OBO is suitable for screed-covered installation in dry and wet-cleaned floors.



OBO testing standard

DIN EN 50085-2-2 specifies the load requirements for electrical installation systems. According to this standard, cassettes may only bend by a maximum of 6 mm when subjected to a load. However, with harder floor coverings, such as stone or tiles, bending of 6 mm will lead to breakage. For this reason, OBO has increased its internal quality criteria and goes a step further with the OBO testing standard: The maximum bend for heavy-duty systems was reduced from 6 mm to 2 mm. The tests according to the OBO testing standard take place in the company's own BET Test Centre.



Heavy load testing

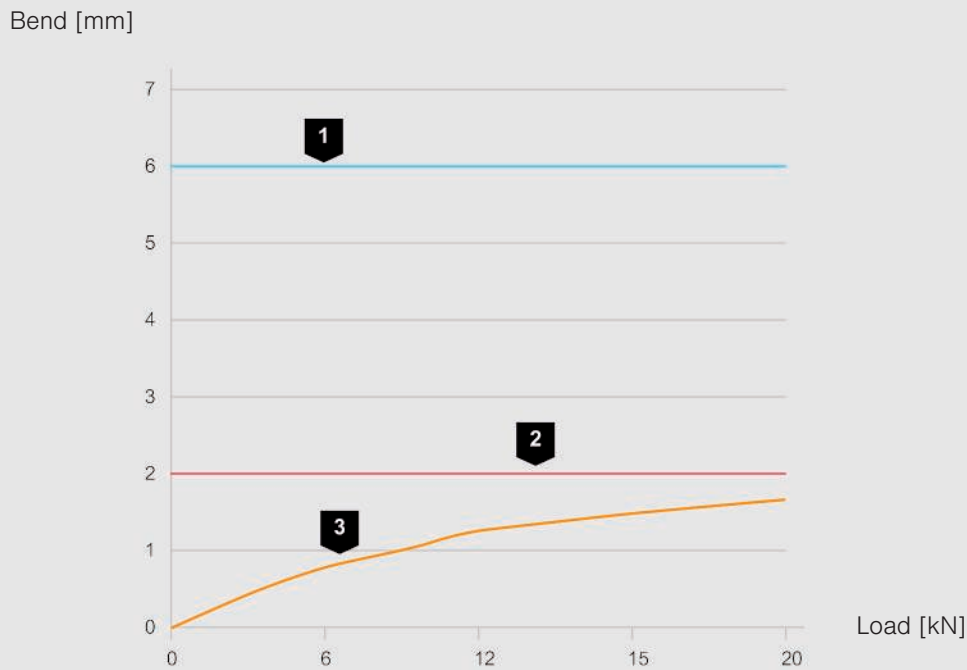

Tested heavy-duty system components:

- Underfloor junction and branch box of size 350-3
- Heavy-duty support, heavy-duty mounting lid
- Floor covering, tile, 20 mm
- Cassette RKF2 SL2 V3 35

1	Bend to DIN EN 50085-2-2: 6 mm
2	Bend to OBO testing standard: 2 mm
3	Measured bend, OBO heavy-duty system

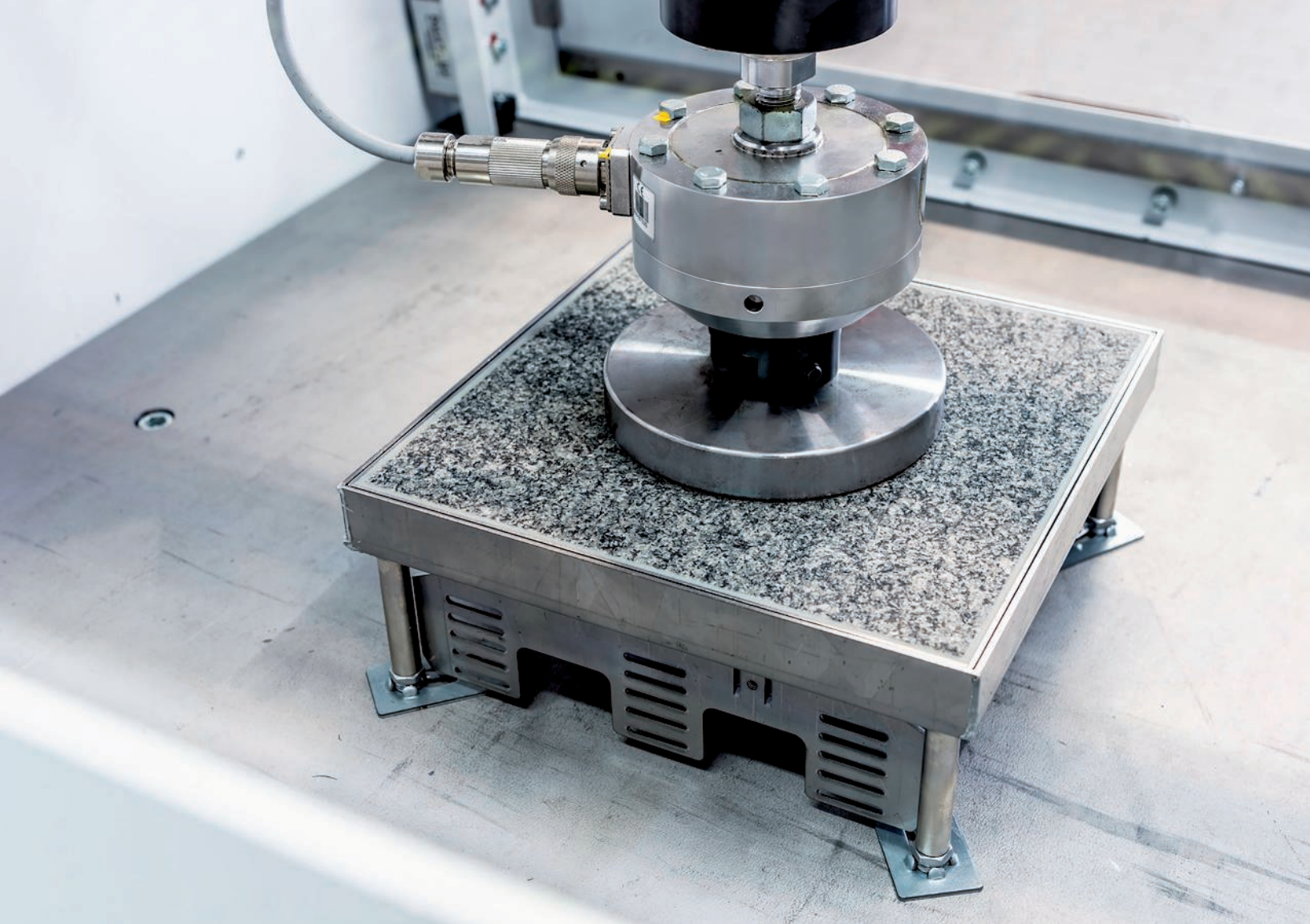

OBO heavy-duty classes

Classification

DIN EN 50085-2-2 divides the load capacities of electrical installation duct systems into two classes. The classifications rate the articles according to resistance to vertical loads that act over a small (6.102) or large (6.103) surface area. The 6.103 classification and the test results from the BET Test Centre served as a basis for the development of the internal OBO classification into heavy-duty classes SL1 and SL2. Products of heavy-duty class SL1 are suitable for loads of up to 10 kN, whilst products of heavy-duty class SL2 are even suitable for loads of up to 20 kN. The maximum bending for both heavy-duty classes is 2 mm.

Class 6.103 according to DIN EN 50085-2-2

Classification*	Load in N
6.103.1	2,000
6.103.2	3,000
6.103.3	5,000
6.103.4	10,000
6.103.5	15,000

* The OBO heavy-duty classes were developed based on Class 6.103.

Classification according to the OBO testing standard

OBO heavy load class	Load in N
SL 1	10,000
SL 2	20,000

The screed-covered solution

The screed-covered heavy-duty solution consists of six system components: The underfloor ducts, underfloor sockets, heavy-duty supports, heavy-duty mounting lids, height-adjustment units and heavy-duty cassettes. The 2 or 3-compartment underfloor ducts are used for cable routing and can easily be connected to the prepared installation openings of the underfloor sockets. The underfloor sockets permit the installation of heavy-duty cassettes for inspection purposes or for the mounting of installation accessories such as sockets, data or multimedia technology. The heavy-duty supports and the special heavy-duty mounting lid provide the necessary stability. The heavy-duty cassettes are inserted in the heavy-duty mounting lid, allowing access to the installed installation devices.

Underfloor junction and branch box

The underfloor sockets of the nominal sizes 250 and 350 must have a non-positive connection to the screed. To avoid a reduction in the load capacity and damage to the floor covering, no edge insulation strips can be laid around the underfloor junction and branch box.



Heavy-duty cassettes

Heavy-duty cassettes are suitable for creating inspection openings or for the installation of devices in areas with high load requirements. The cassettes are adequately dimensioned for absorbing traffic loads and are rated for individual static loads up to 10 kN (SL1) or 20 kN (SL2). The GRAF9 service outlet is available for smaller loads up to 7.5 kN.



Heavy-duty mounting lid

The heavy-duty mounting lid is selected according to the appropriate heavy-duty cassette. The height-adjustment units enable the screed-flush height adjustment of the heavy-duty mounting lid and are to be ordered separately.



Heavy-duty supports

Heavy-duty supports are additional expansion parts for underfloor sockets and increase the load capacity. The supports are inserted in the corner areas of the underfloor box and are tensioned under the socket frame.



Ducts

The screed-covered ducts are only subjected to loads during the mounting period. Before screed laying, the ducts are classified with a load capacity of 750 N according to DIN EN 50085-2-2. After screed laying, no loads impact on the ducts, as the screed accepts the loads as a static layer. For this reason, underfloor ducts from the standard product range can also be used in areas with high load requirements. 2 and 3-compartment underfloor ducts from the EÜK screed-covered duct system are available.



08_UFS_en / 2019/07/18 10:39:53 / 2019/07/18 10:39:53 (LIEsport_02520) / 2019/07/18 10:40:17 / 2019/07/18 10:40:17

Overview of heavy-duty systems

Device installation units

Selection according to

- Load requirement
- Floor covering thickness
- Functional method
- Installation capacity

Cassettes for cable outlets and inspection purposes protect the electrical installation in the floor against water penetration. All heavy-duty solutions guarantee moisture protection according to DIN EN 50085-2-2 and are therefore approved for wet-cleaned floors indoors.

Heavy-duty mounting lid

Selection according to

- The shape of the selected service outlet or the cassette (nominal size)
- Screed height

With heavy-duty frame cassettes, a mounting set, not a mounting lid, must be used for the installation of installation devices.

Height-adjustment units

Selection according to

- Screed height

Heavy-duty supports for underfloor socket

Selection according to

- Screed height

Underfloor socket (UZD)

Selection according to

- Screed height
- Shape of the cassette and the heavy-duty mounting lid
- Duct width

Ducts

Selection according to

- Cable volume

Load capacity

7.5 kN



Service outlet



Heavy-duty mounting lid



Height-adjustment units



Heavy-duty support

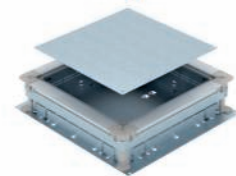

Underfloor socket, nominal size 350



10 kN
SL1

Square heavy-duty cassettes



20 kN
SL2

Round heavy-duty cassettes

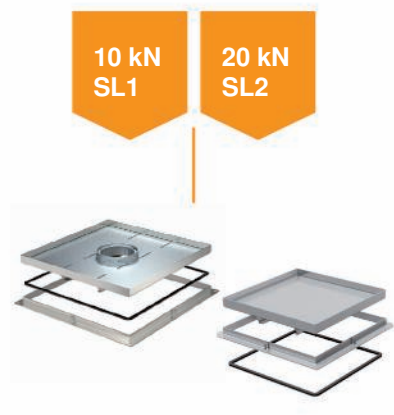

10 kN
SL1 20 kN
SL2

Heavy-duty frame cassettes



Heavy-duty mounting lid



Heavy-duty mounting lid



Mounting set



Height-adjustment units



Height-adjustment units



Heavy-duty support

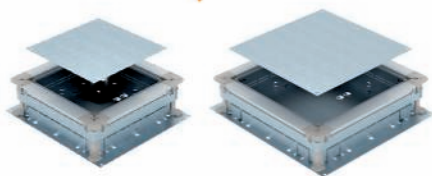

Underfloor socket, nominal size 250 and 350

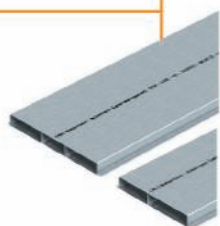

Trunking in various widths, 2-compartment and 3-compartment

Installation and floor cut-out dimensions



Various installation and floor cut-out dimensions must be taken into account for the mounting of height-adjustable cassettes and the application of floor coverings in the cassette lids.

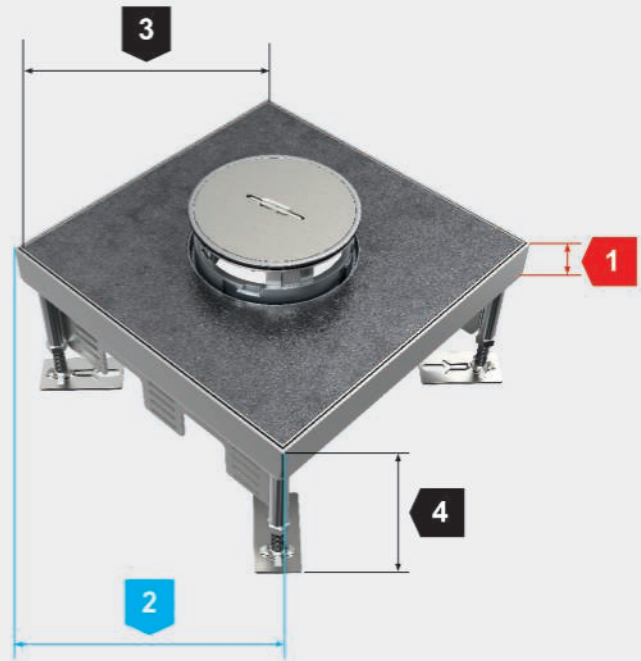
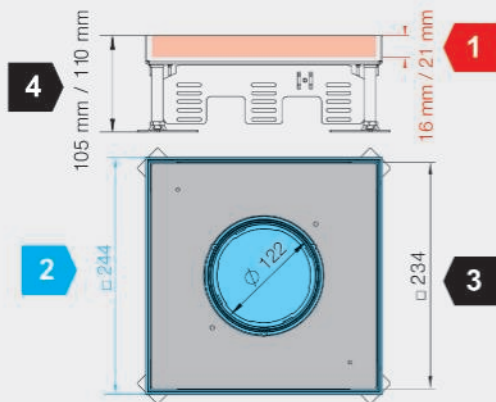

1

Frame height for the floor covering in the lid (red dimensions)

The frame height data relates to the maximum floor covering thickness, including adhesive. The cassettes are available in various frame heights.

2

Floor cut-out for the installation of cassettes (blue dimensions)

The dimensions for the floor cut-out should be considered as target dimensions for correct installation of the cassette in the floor. They are only generally required for the floor cut-out in system floors. The EÜK screed-covered duct system or the OKA open trunking system offer prefabricated mounting lids with matching installation openings.

3

Internal dimension of the lid to determine the floor covering cut-out (black dimensions)

The dimension data relates to the internal dimension of the cassette lid and is used to calculate the floor covering cut-out. Depending on the type of floor covering, appropriate reductions should be taken into account, e.g. for expansion gaps.

4

Minimum floor structure height (raw concrete ceiling to finished floor)

The dimension describes the minimum floor structure height from the raw concrete ceiling to the top edge of the finished floor. It guarantees correct installation and use of installation devices, such as sockets, data and multimedia connections.

System dimensions, height-adjustable square cassettes

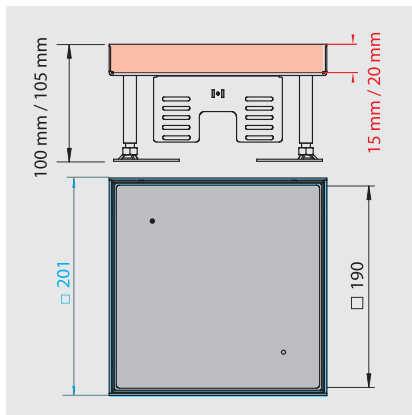

Nominal size 4, type RKN2 4

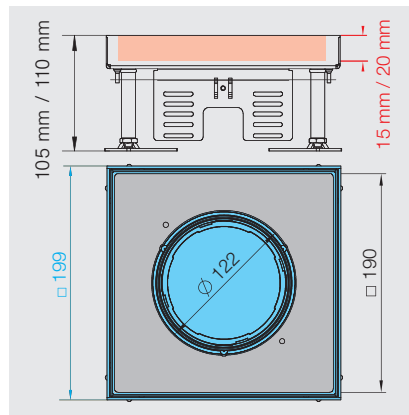

Nominal size 4, type RKFN 2 4

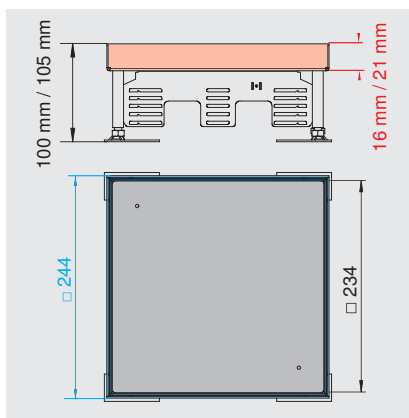

Nominal size 9, type RKN2 9

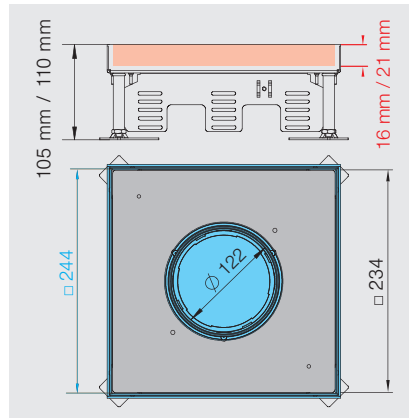

Nominal size 9, type RKFN 2 9

System dimensions, height-adjustable round cassettes

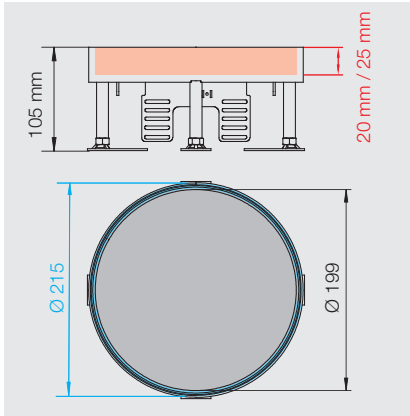

Nominal size R4, type RKR2 and RKRN2

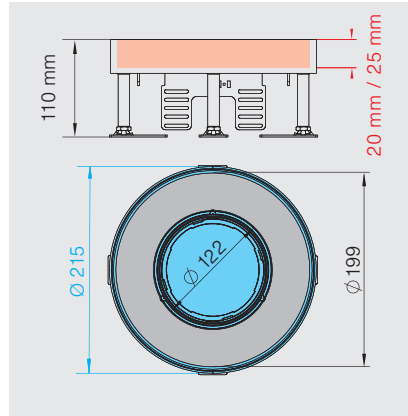

Nominal size R4, type RKFR2 and RKFRN2

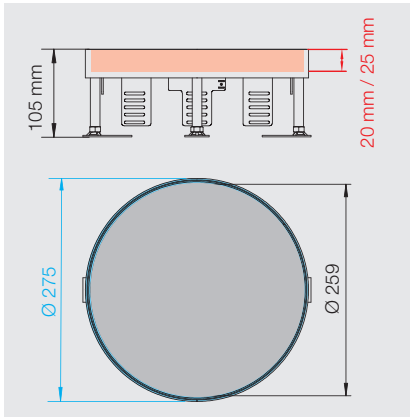

Nominal size R7, type RKR2 and RKRN2

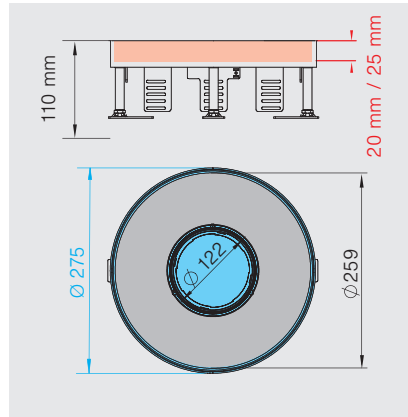

Nominal size R7, type RKFR2 and RKFRN2

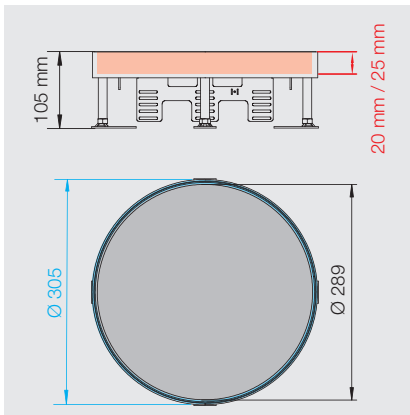

Nominal size R9, type RKR2 and RKRN2

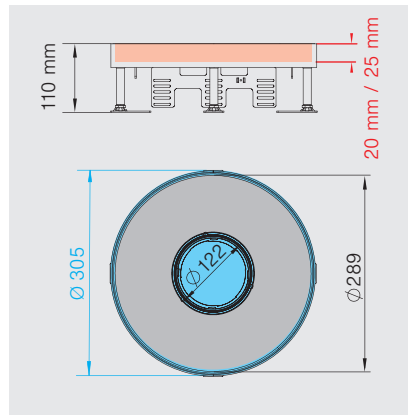

Nominal size R9, type RKFR2 and RKFRN2

System dimensions, frame cassettes

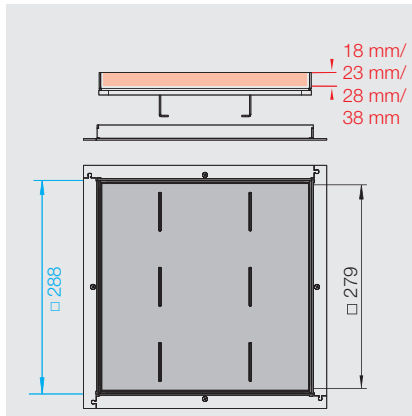

Nominal size 250-3, type RK SL1

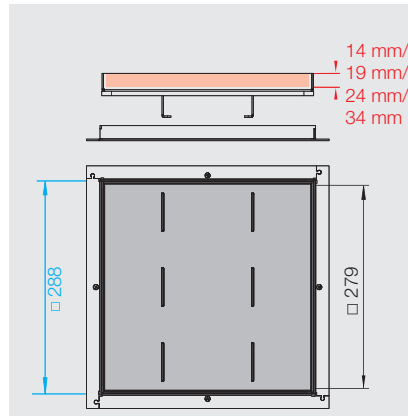

Nominal size 250-3, type RK SL2

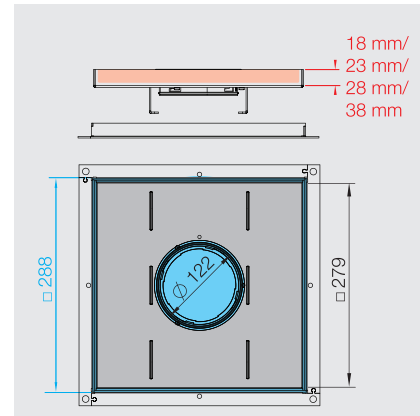

Nominal size 250-3, type RKF SL1

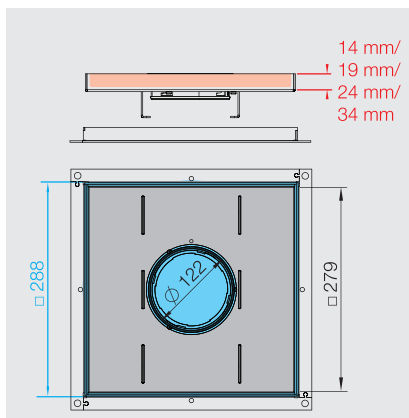

Nominal size 250-3, type RKF SL2

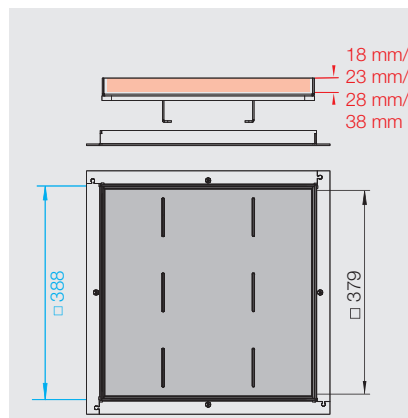

Nominal size 350-3, type RK SL1

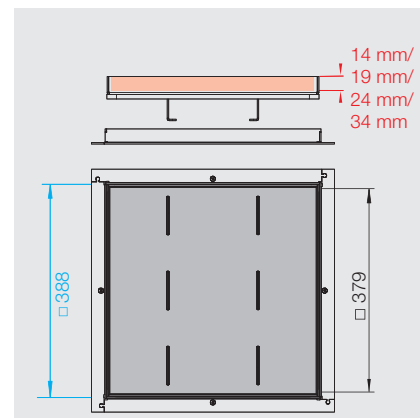

Nominal size 350-3, type RK SL2

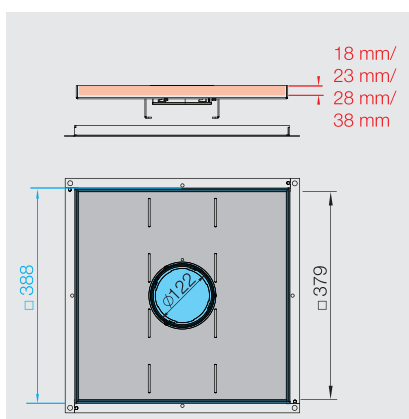

Nominal size 350-3, type RKF SL1

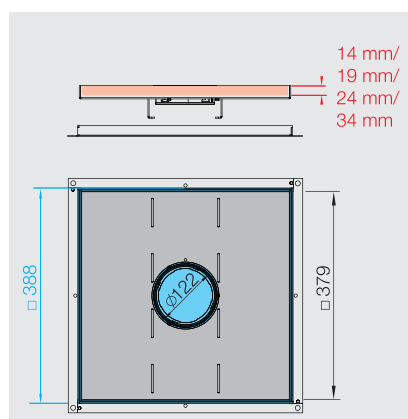

Nominal size 350-3, type RKF SL2



Planning checklist

When planning heavy-duty systems, the following points should be observed:

- ✓ Match floor structure, payloads and area loads
- ✓ Observe the minimum installation depths of device installation units
- ✓ The underfloor socket must sit entirely on the concrete floor. Cavities under the socket strongly reduce the load capacity
- ✓ The underfloor socket must have a non-positive connection to the screed. Do not apply a separating strip between the underfloor socket and the screed
- ✓ Work floor coverings exactly up to the opening of the blanking lid, e.g. GRAF9 Ø 305+1 mm
- ✓ Stick down the floor coverings onto the surface of the underfloor boxes and in the lid of the cassettes fully and firmly



Floor sockets and floor boxes: for perfect power and data connections

The family of UDHOME complete units can locate power, data and multi-media connections exactly where they are required. Floor sockets and floor boxes of the UDHOME family are mounted directly on the raw floor and are connected with flexible installation pipes – it couldn't be simpler.



UDHOME2



UDHOME4

Elegant, discreet and robust

Thanks to their elegant, discreet design, UDHOME floor sockets and floor tanks integrate themselves seamlessly into the interior architecture. When the hinged cover is closed, only the high-quality surfaces of pure stainless steel or solid brass are visible. Thanks to their stable construction, the floor sockets and floor tanks are also resistant to the everyday loads in homes, offices and administrative areas.



Easy handling from ordering to mounting



High-quality materials and solid processing



Maximum flexibility in equipment

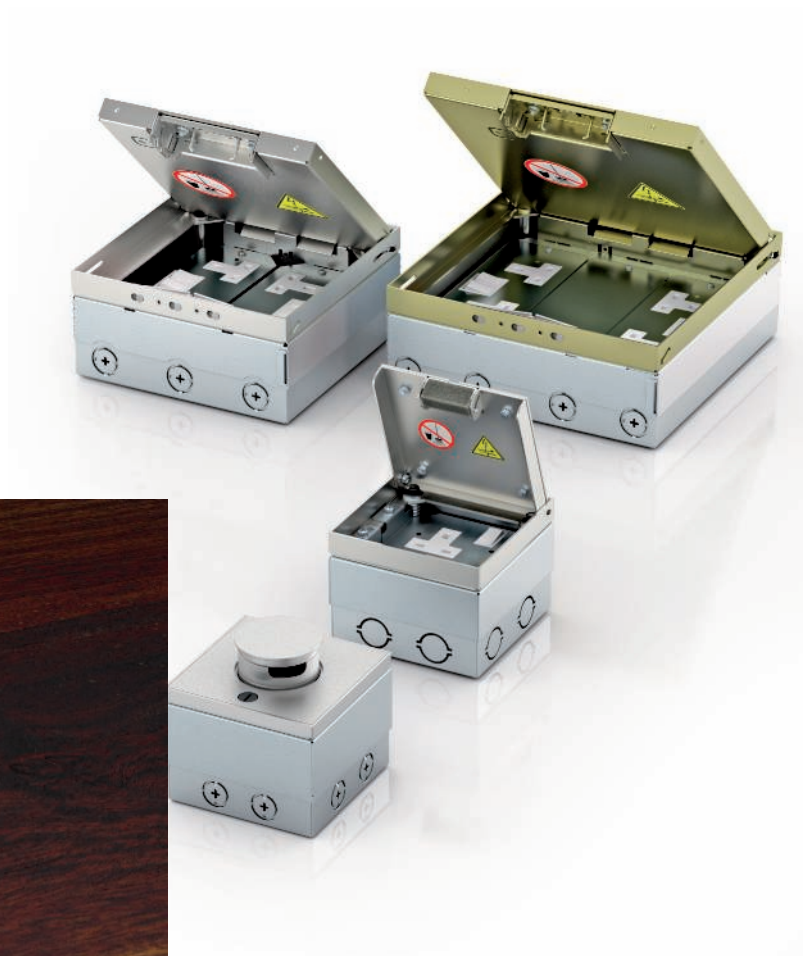

UDHOME9

A special customer: Old Master in a new light

Architect: Michele de Lucchi Museo della Pietà

The Museo della Pietà in Milan is home to the last, uncompleted masterpiece by Michelangelo: The Pietà Rondanini. The 89-year-old master worked on the sculpture, which depicts Jesus and Mary, just six days before his death in February 1564.

The compact UDHOME floor sockets and a special solution of OKA trunking from OBO Bettermann provide a discreet and flexible power supply around the famous sculpture.



Overview of the UDHOME series

Floor boxes

The UDHOME4 and UDHOME9 floor boxes are the ideal solution for a wide equipment range and dry-cleaned floor coverings. The floor boxes offer a lot of space for the installation of power, data and multimedia connections and are available in discreet stainless steel and in stylish brass.

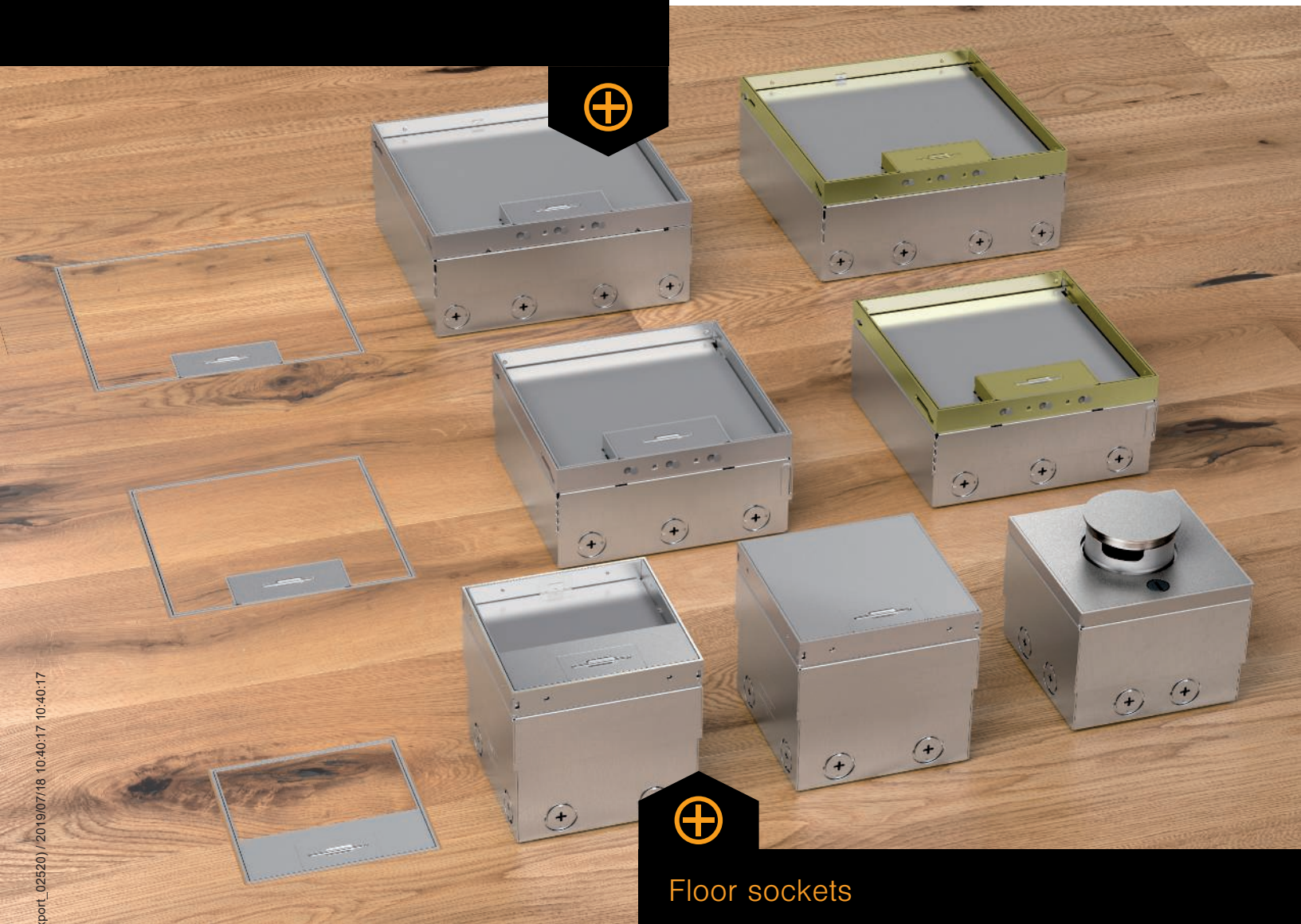

Floor sockets

The UDHOME2 floor sockets, with their dimensions of 125 x 125 mm, combine an elegant appearance and functionality. The product family offers solutions for dry and wet-cleaned floors. Stainless steel or aluminum are used as materials.

Floor structure

Thanks to their compact design, UDHOME floor sockets and floor boxes require considerably less space in the floor than other electrical installation systems do in floors.

Height-adjustment supports

With the easily accessible height-adjustable supports, it is possible to adjust the covers of the floor sockets and floor boxes to the top edge of the floor coverings without any difficulty. The optional height extension means that adjustment is easy, even with higher floor structures.





Tested quality

In addition, OBO tests its ducts and underfloor boxes in its own BET Test Centre. Thus, special solutions can be tested for their load capacity within a very short time.

Simple infeed



The feeding in of cables is not complex. They are simply run in standard empty tubes in the screed up to the UDHOME.



08_UFS/en/2019/07/18 10:39:53 10:39:53 18-10:40:17 (LExport_02520) / 2019-07-18 10:40:17

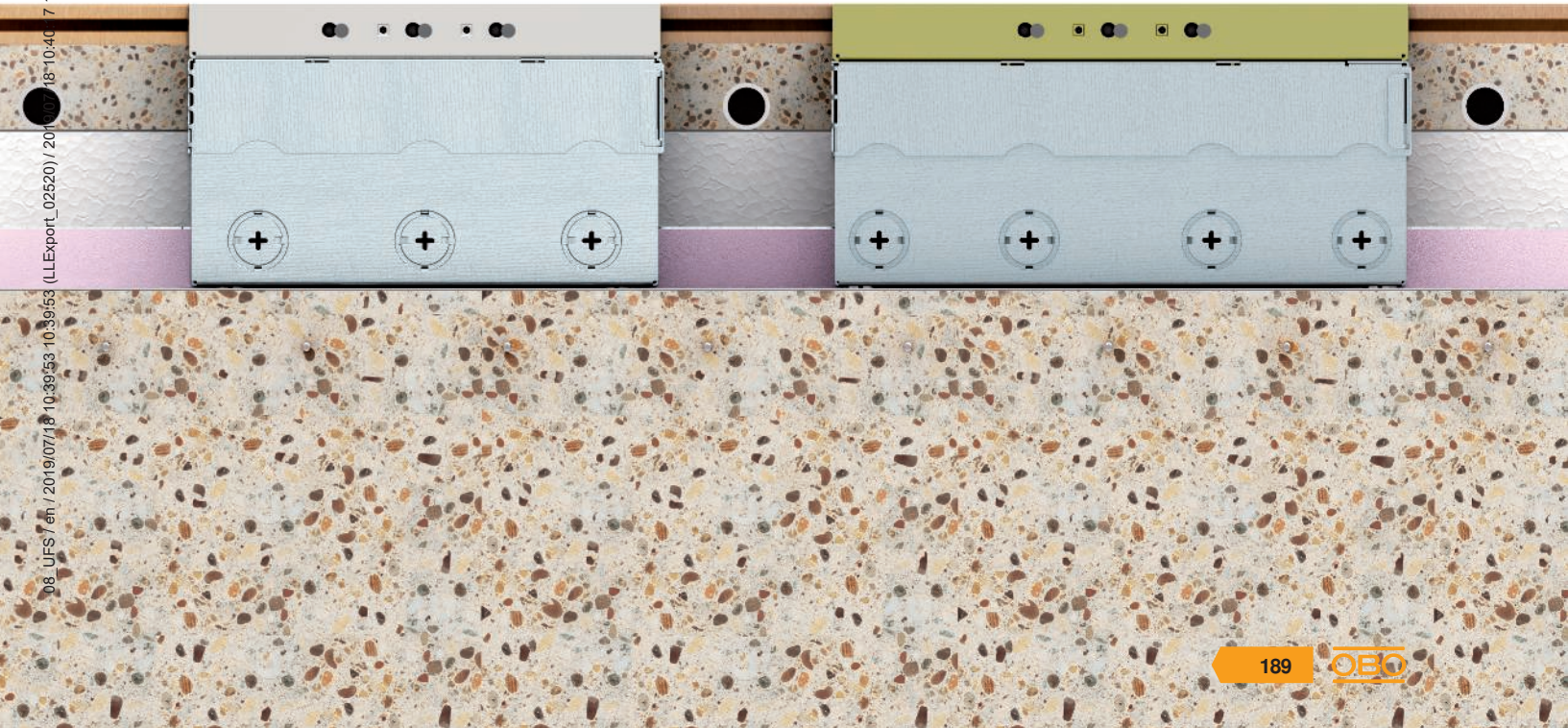

Small but perfectly formed: The UDHOME2 floor socket

UDHOME2 are available in three versions: With stainless steel cover, with floor covering recess and with tube body. With its protection rating of IP65, the floor socket with tube body is suitable for use in wet-cleaned cavity and screed floors.



Height adjustment

The cover is adjustable to the edge of the floor covering using four height-adjustment supports. A height extension with an additional adjustment range of 10–60 mm can be mounted for higher floor structures.

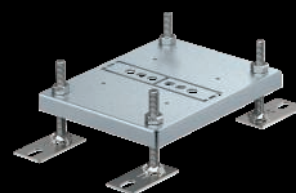

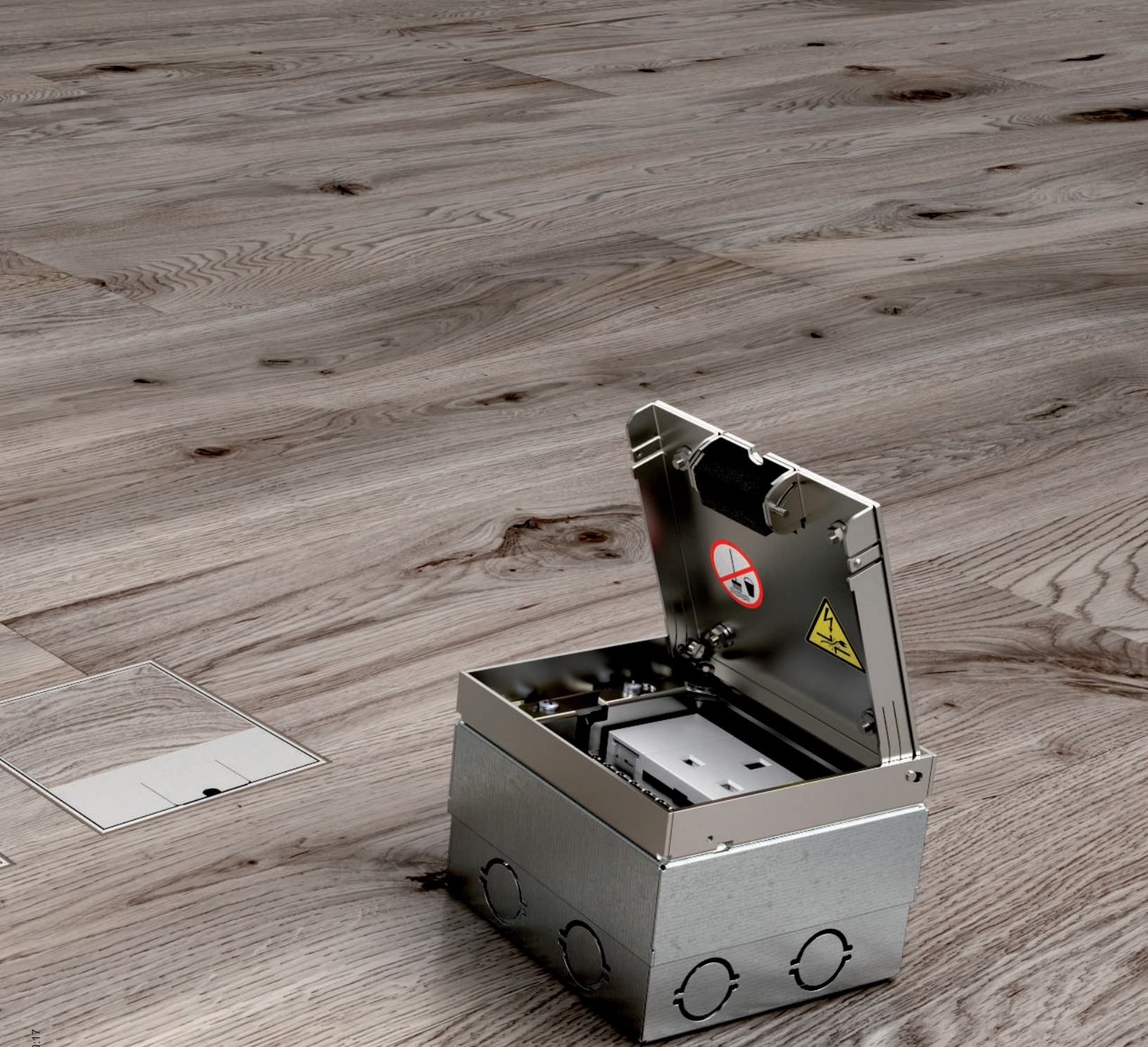

Device installation

The scope of delivery of the UDHOME2 contains a double protective contact socket. Up to two modular data sockets can be installed with the mounting supports.

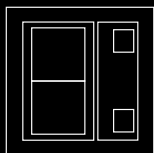

Connection

Eight pre-marked entry openings (M25) allow simple connection with flexible installation tubes.

For a wide range of equipment:
The UDHOME4 floor box



Design

The UDHOME4 can fit neatly into high quality interior architecture. All you can see is a slender metal edge and the cord outlet. The floor box is available in stainless steel or brass versions.

Device installation

The UDHOME4 can be equipped flexibly with power, data and multimedia technology using 4 support ring devices or 6 Modul 45 devices.

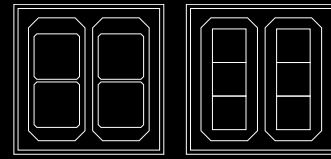

Dimensions

Body: 199 mm x 199 mm
Screed height: 95–110 mm
Floor height: 95–125 mm
Optional height extension



Height adjustment

The flush-mount unit possesses a height-adjustment range of up to 30 mm and can thus be adjusted to the level of the finished floor.



A beautiful figure with powerful connections: The UDHOME9 floor box

Changeable



The UDHOME9 is available in stainless steel and brass versions.



Dimensions

Body: 243 mm x 243 mm
Screed height: 95–110 mm
Floor height: 95–125 mm
Optional height extension

Device installation

The UDHOME9 can be equipped flexibly with power, data and multimedia technology using 9 support ring devices or 12 Modul 45 devices.

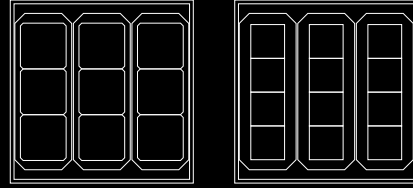

Installed

The UDHOME9 is the largest floor box of the UDHOME family. It combines restrained design with a wide range of use options.

Device installation

The UDHOME family can be equipped flexibly with power, data and multimedia technology. Our extremely comprehensive Modul 45 programme is available for this. However, you can also use standard devices from other manufacturers.

Maximum flexibility

For maximum flexibility, the floor sockets and floor boxes can, depending on requirements, be equipped with the comprehensive Modul 45 series from OBO Bettermann or with standard devices. Both sockets and data and multimedia technology of the Modul 45 series are simply snapped in, without tools, making work quicker and thus cheaper.

The system can be used for a wide range of applications, thanks to the standardised installation dimensions of 45 x 45 mm and the large range of variants (e.g. HDMI, USB and audio connections).





Floor socket

UDHOME2

2 Modul 45 devices
2 data technology modules

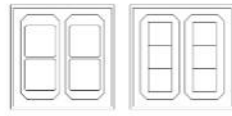

Floor box

UDHOME4

4 support ring devices
6 Modul 45 devices

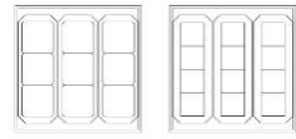

Floor box

UDHOME9

9 support ring devices
12 Modul 45 devices



Pre-equipped with
2 x Modul 45 sockets



Option 1: Installation of up to 6
devices when equipped with 2
universal supports
(type UT3 45 3)



Option 1: Installation of up to 12
devices when equipped with 3
universal supports
(type UT4 45 4)

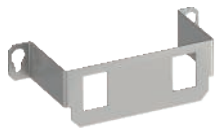

Mounting support for data technol-
ogy for the optional installati-
on of 2 additional data technol-
ogy modules



Option 2: Installation of up to 4
devices when equipped with 2
support ring device supports



Option 2: Installation of up to 9
devices when equipped with 3
support ring device supports



GES R2 floor sockets

The round floor sockets of the GES R2 series supply data and power exactly where they are required. Their handling is simple: The connection lines are inserted in the compact installation space and that space is closed off with a lid. Depending on the lid version, the floor sockets are suitable for dry or wet-cleaned floors.



Areas of application

OBO GES R2 floor sockets are an ideal underfloor solution when a discreet appearance, a high load capacity and varied functionality are required. Whether in the living room or in public areas – such as foyers, shopping centres or exhibition areas – the floor sockets stand out through their fine design and also add value to high-quality floor areas.

The installation socket of the GES R2 floor sockets is pre-equipped with two sockets. To the side of the socket, there is space for up to two connection sockets for data technology applications, as an option.

The floor sockets of the GES R2 series are available in various materials. The die-cast zinc variant is available surface-treated in the shades nickel, chrome, old copper and old brass and is certified to IP66 in the unused state.



Ideally suited to wet-cleaned floors



Withstands the highest loads



In use around the world for decades

08_UFS / en / 2019/07/18 10:39:59 4000953 (LLExpert_08520) / 2019/07/18 10:40:17 10-40

Modular structure

The GES R2 floor sockets offer the tried-and-trusted functions of the Ackermann made by OBO underfloor systems – now newly constructed and with an up to 100% larger installation compartment compared to the predecessor model GESRM2. This provides space for a double socket of the Modul 45 series and up to two data modules.

The modular structure as a screed socket, installation socket and service outlet allows simple configuration, according to the area of application.

Lid variants

The classic service outlet for the GES R2 floor socket is available in various designs.



Installation socket

The installation socket is available empty or pre-equipped. The pre-equipped variant contains either a double socket or a free combination of two Modul 45 individual devices.

Screed box

The height-adjustable screed box is used to accept the service outlet when the GES R2 floor socket is installed in the screed.

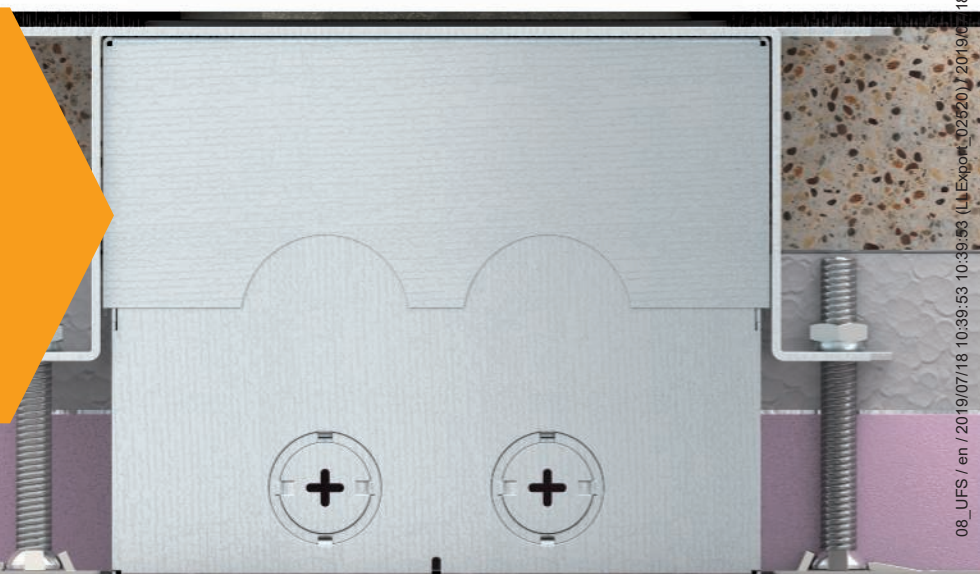

Variable

All the cover variants of the GES R2 floor socket can be inserted in raised floors or in the screed.



Installation in system floor

The installation socket can be installed simply in the system base. A drill hole of 122 mm is sufficient.



Mounting

The installation socket is mounted in the raised floor plate using three fastening brackets.

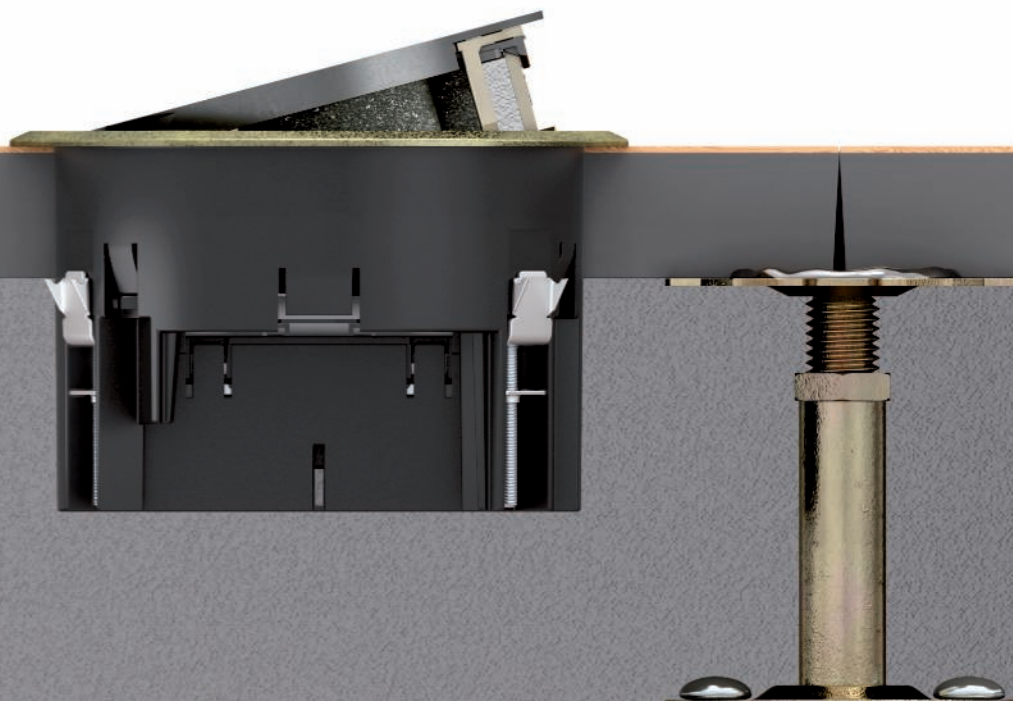

GES R2 floor socket for wet-cleaned floors

The tube body seals the closed installation space against the ingress of water, which occurs, for example, when the floor is cleaned. Even if the tube body cover is open for letting out cables, a seal in the lower ring of the installation socket offers protection against the ingress of water. The GES R2 floor socket with tube body thus fulfils the requirements for service outlets in wet-care floors according to EN 50085-2-2 and is certified to IP66 in the unused state.

Tube body

The tube body can be operated with one hand. To open it, the handle clamp is pulled up and, after the audible engaging of the support, turned slightly left and locked.

To insert the cables, it is sufficient to press two pressure points to release the cover. After the connectors have been inserted, the cover is audibly engaged on the tube body ring. The tube body cover is closed again by pressing the pressure points and lowering the cover by turning it to the right slightly.



IP
66

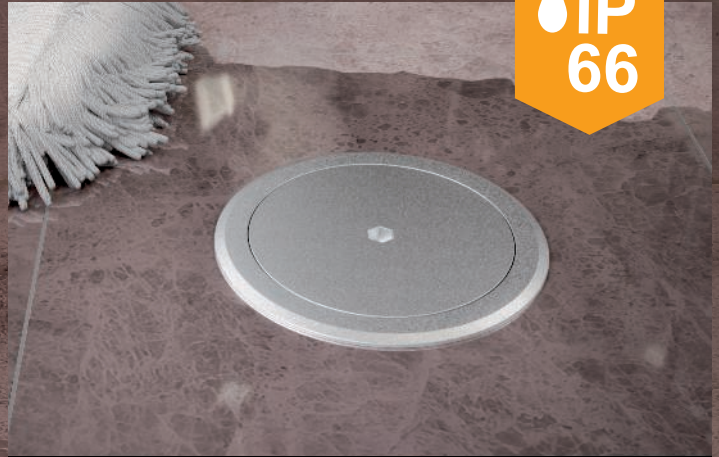

Blank version with metal lid

The metal cover with bayonet lock can be opened with an Allen key.

This version is particularly suitable for public areas and the supply of temporary installations.



Surfaces

The GES R2 floor socket with tube body stands out through its compact shape and discreet design. Four high-quality surfaces are available: Nickel, old brass, chromium and old copper.

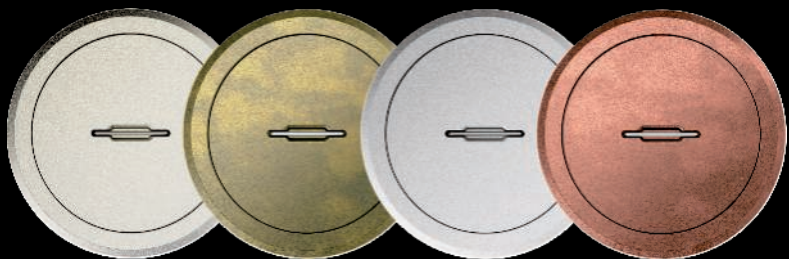

The GES R2 floor socket with hinged lid stands out through its fine design. It is the perfect solution for high-quality floor coverings, which are dry-cleaned.

Hinged lid

The locking function of the hinged lid allows a secure outlet for the cable routing. When closed, the floor socket is even suitable for wet cleaning.





Surfaces

The version with hinged cover is available in the colours nickel, old brass, chromium and old copper.



GES R2 floor socket with cord outlet



The plastic GES R2 variants are particularly suitable for construction projects, which use carpet as the floor covering. Typical areas of application are office and administrative buildings.

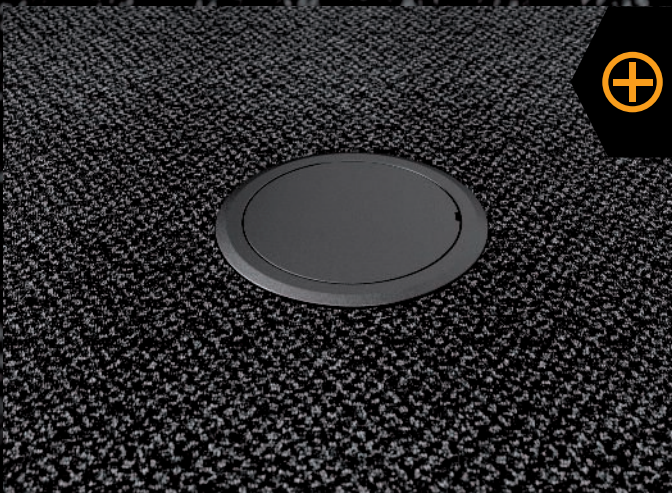
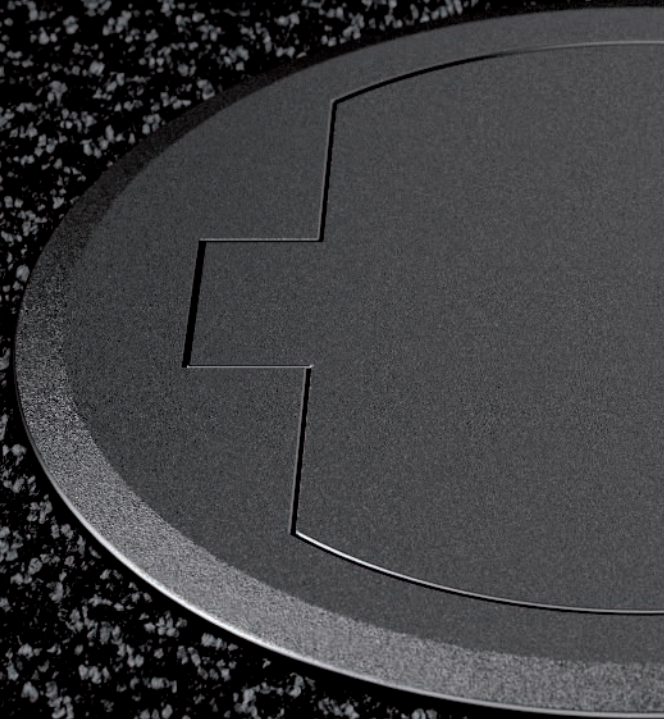

Cover versions

Two lid variants are available: The lid variant with cord outlet provides a permanent cable outlet to supply the electrical resources. The version with blanking lid, which can only be opened with a screwdriver, protects against unintentional third-party access.



Protective frame

The floor covering protection frame protects the carpet against damage and prevents wear at the cut edges of the carpet.



Colours

The plastic floor sockets are available in the colours iron grey or graphite black.

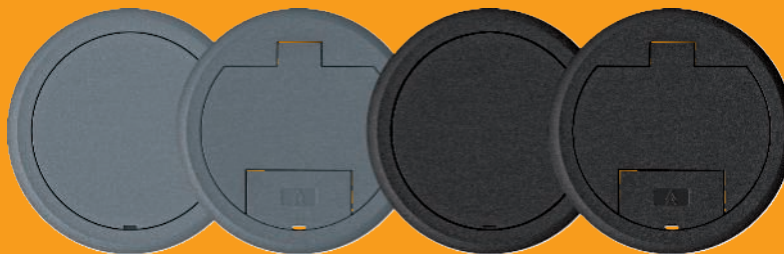

Installation socket for Modul 45

The installation socket for GES R2 service outlets accepts Modul 45 devices. After the routing of the electrical installation, the installation socket is inserted in the screed box.

Separation of different current types

The large installation socket offers separate installation spaces for heavy current connections and data or multimedia connections.



Functional

The installation socket possesses break-out cable entries and an integrated strain relief.



08_UFS / en / 2019/07/18 10:39:53 (LLExport_02520) / 2019/07/18 10:40:17 10:40:17

Varied installation options

The pre-equipped installation socket, which contains a double socket of the Modul 45 series, is suitable for standard applications. The variant for two single Modul 45 devices offers a great amount of installation flexibility. The installation space is separated here. This allows simultaneous installation of sockets, data and multimedia connections, such as HDMI or VGA.



Solid hold

The fixing bracket is used to fasten the installation socket in raised and cavity floors or in the screed box.

Mounting of the underfloor box in the screed

Installation in the screed box

The GES R2 floor sockets are installed in the screed in the compact screed box. The screed box possesses a sturdy pressure acceptance plate, whose frame serves as the screed drip edge. The mounting protection lid of the screed box is knocked out after the screed work has been completed. This makes the installation opening for the service outlet accessible.



Connection

Cables are routed via flexible installation pipes in the insulation layer of the screed construction. The screed box possesses four break-out pipe entries.



Screed-flush drip edge

The outlet edge of the screed box ensures sufficient stability and load dissipation in the area. The installation socket and the service outlet are installed after the floor covering work has been carried out.



Height adjustment

Using a simple 3-point height adjustment, the screed box can be adjusted exactly to the top edge of the screed. The height adjustment ranges from 85 to 130 mm.



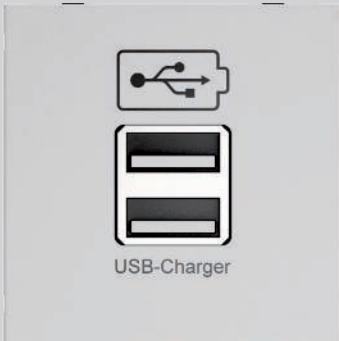
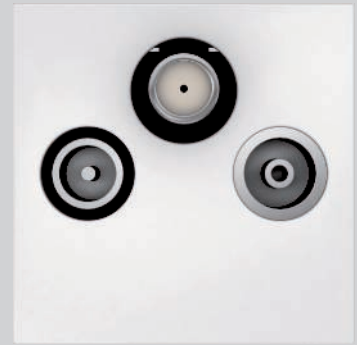

Modul 45® and Standard – installation solutions for underfloor systems

The Modul 45 devices from OBO Bettermann are compact and space-saving. They are thus ideally suited for use in underfloor systems. The Modul 45 system makes optimum use of limited installation space.

The advantages of Modul 45 at a glance:

- Space savings thanks to compact design
- Modular structure
- Quick and easy planning
- Easy mounting
- High efficiency due to time and cost savings
- Wide range of application options
- Easy exchangeability

In service outlets



In cassettes

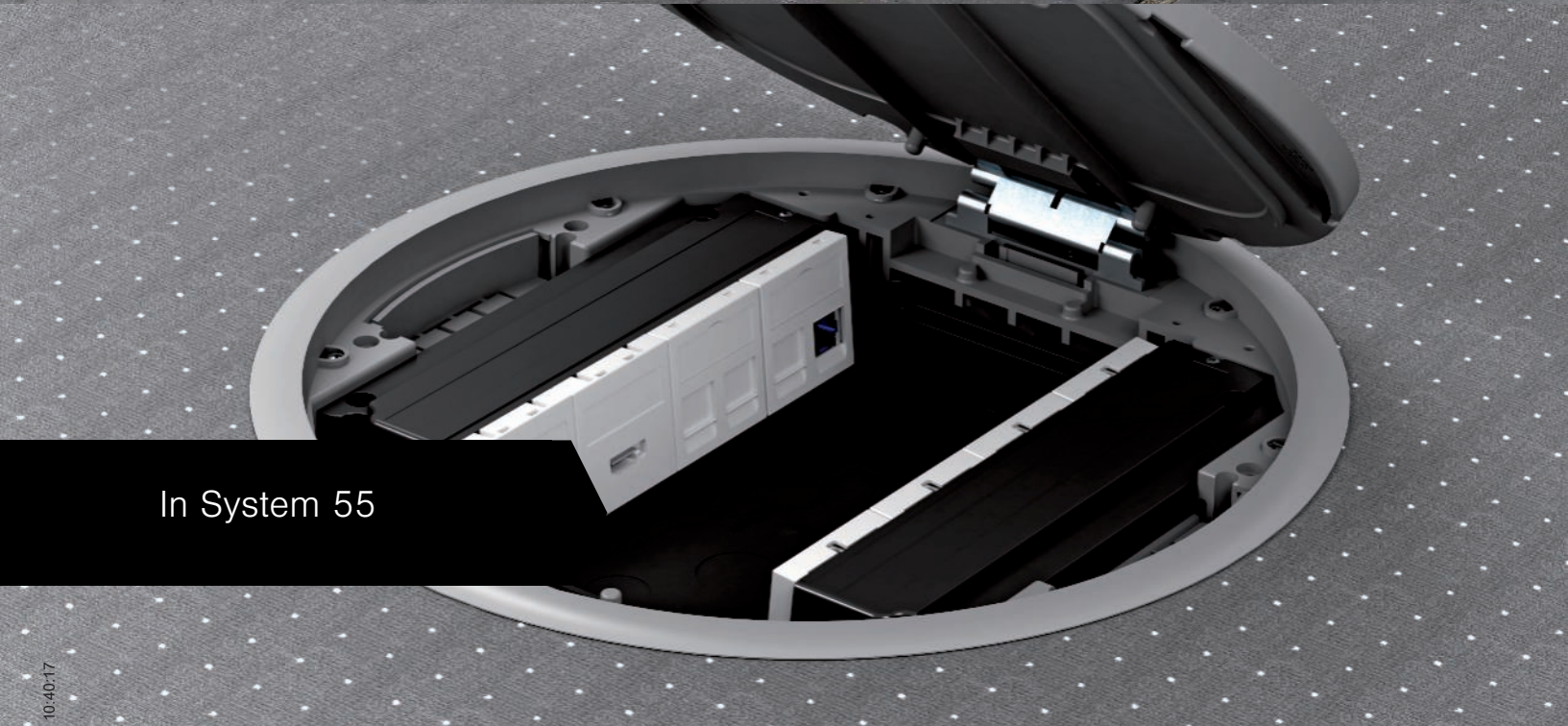

In System 55



In the OKB system

08_UFS / en / 2019/07/18 10:53:53 10:59:53 (LIEExport_02520) / 2019/07/18 10:40:17 10:40:17

Solutions for device installation

The Ackermann made by OBO installation systems offer a wide range of options for device installation in service outlets and cassettes with a locking ladder. Power, data and multimedia connections can be combined as required and positioned at various heights in the locking ladder.

Four solutions are available for device installation:

- Universal support UT3 and UT4 for the installation of Modul 45 devices and standard installation devices with 50 mm central plate
- MTU mounting support for the integration of data and multimedia technology of various manufacturers
- MT45V module support for vertical installation of Modul 45 devices
- GT device support for the installation of CEE connection units



Universal support





Module support

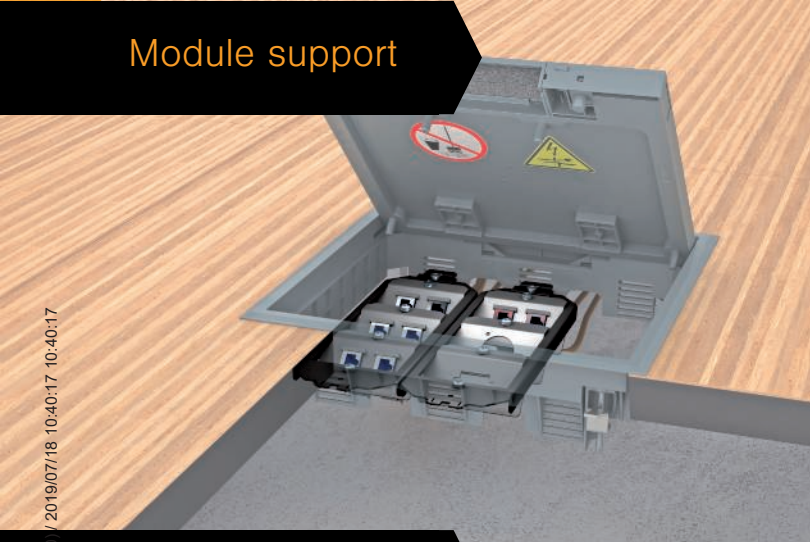

CEE installation

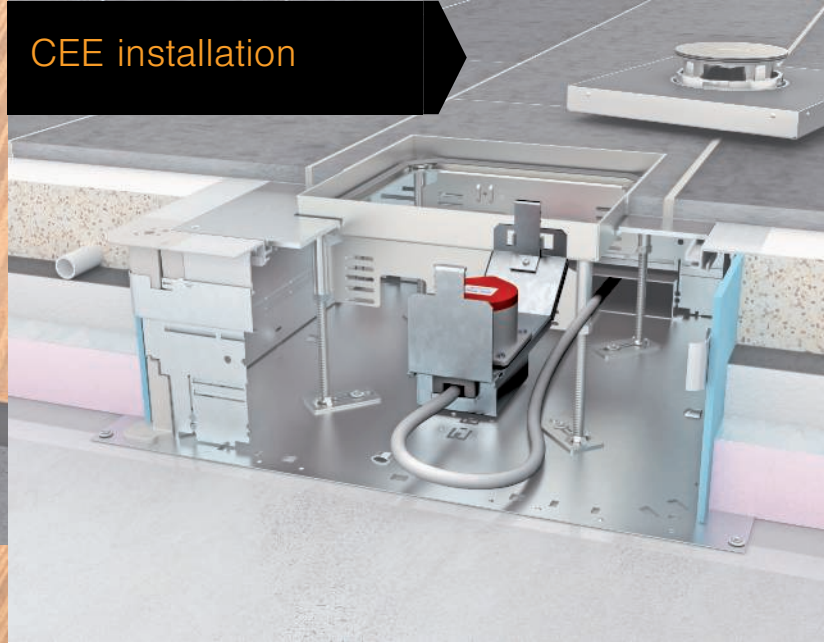

Vertical installation

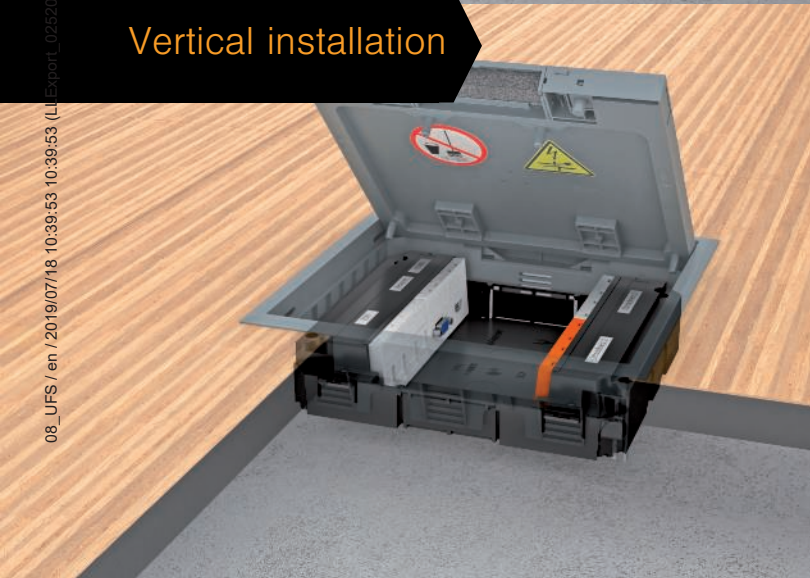

08_UFS / en / 2019/07/18 10:39:53 (LI_Export_02520) / 2019/07/18 10:40:17 10:40:17

Fully modular: The universal support

The universal support is designed for the installation of Modul 45 devices and standard installation devices with 50 mm central plate. It offers countless combination options for sockets, data and multimedia technology.



Cover plates for flexible device equipment

With the universal support, device equipment is determined by the selection of the cover plates. The universal support has space for up to four Modul 45 devices. Combinations of Modul 45 devices and standard installation devices are also possible. The cover plates have practical labelling panels for clear labelling of sockets.



Support frame with innovative turn buckle

The universal support is fastened in the locking ladder of a cassette or a service outlet with a turn buckle. The turn buckle simplifies and accelerates mounting: The universal support is installed and safely locked with just a few actions.

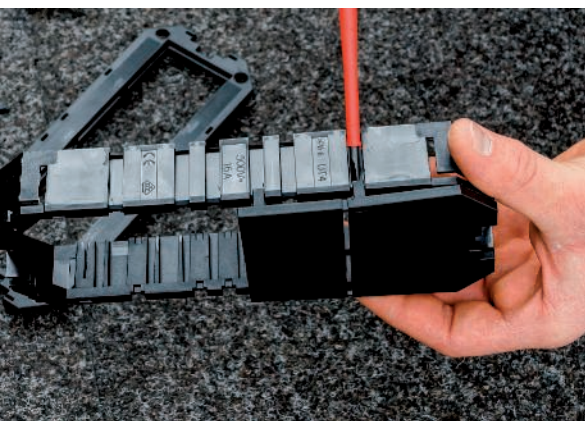

Removable floor plate

The floor plate can be removed, either partially or completely. The benefit: When installing data and multimedia technology, the cables can simply be run downwards out of the universal support.

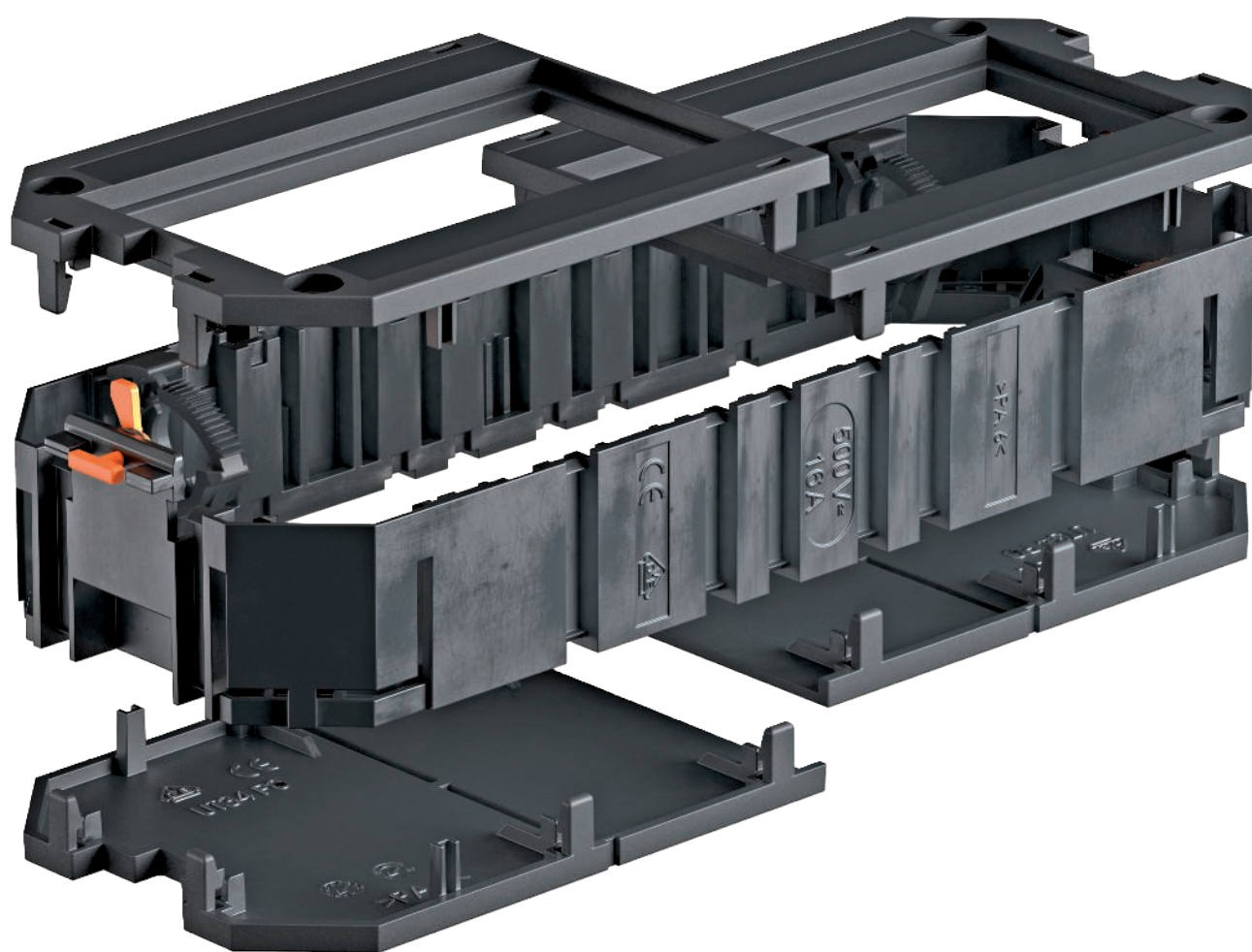

Varied combination options

The compact Modul 45 devices can be combined at will in the universal support, allowing maximum equipment of a device installation unit. Combinations of sockets, data and multimedia technology and standard installation devices with a 50 mm central plate are possible.

Maximum equipment of Modul 45 devices per device installation unit

Nominal size	Universal support	Modul 45 devices
2	1x UT3	3
4 and R4	2x UT3	6
6	3x UT3	9
7	2x UT3 + 1x UT4	10
9 and R9	3x UT4	12

Toolless mounting

Modul 45 devices are simply snapped into the cover plate and connected. The connection cables are fixed according to the standard using the supplied strain reliefs. Finally, the cover plates are placed on the universal support and engaged.



Two circuits with separating retainer

The installation of two circuits in a universal support is made easy through the use of the matching partition. The partition can be positioned according to the device equipment in the universal support. The partition can be ordered separately.



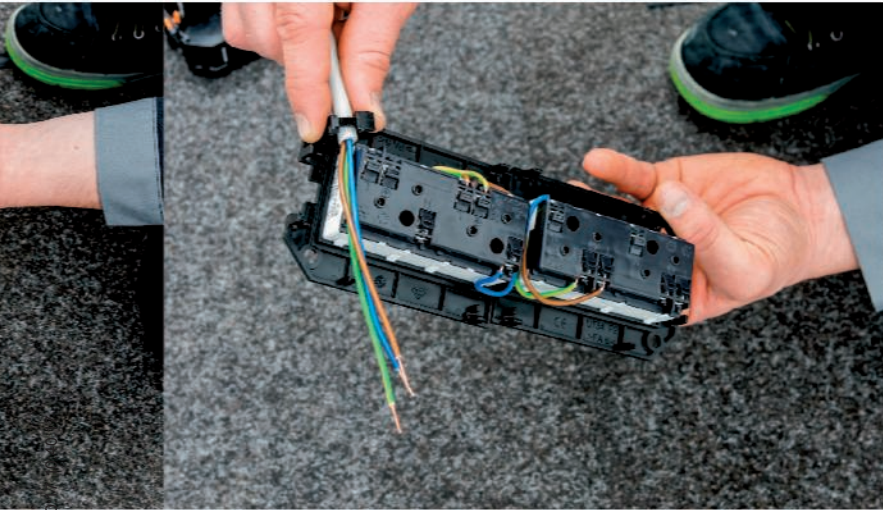

08-1157-am-2019/07/18-10:53 (LLEXP-INT_02520)/2019/07/18-10:40

Installing data technology

When installing data and multimedia technology, more space is required for the cable connection and the supply cable. In this case, the floor plate can be removed, either partially or completely, on the universal support. To install individual devices, such as the data technology support, additional mounting bridges must be mounted in the cover plate. The mounting bridges can be ordered separately.

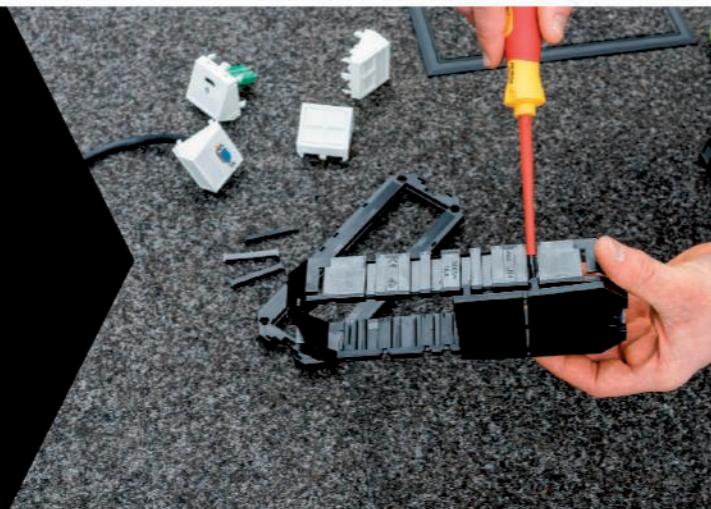

Combining power and data technology

The universal support means that device combinations of sockets and data technology are easy. In the universal support, the installation area for sockets can be closed off with a separating retainer to offer touch protection. The floor plate in the data and multimedia technology installation area can be removed to create sufficient space for cable routing. When sockets are combined, mounting bridges should be inserted between the devices.



Inserting a universal support

To create the largest possible amount of free space for the device connectors, the universal support is inserted in the lowest possible locking ladder track. After this, the turn buckle is first pushed towards the locking ladder, then swivelled to the side and engaged. The universal support is then securely fastened in the device installation unit.





Installation principle, universal support

The type of cover plate determines which installation devices can be inserted in the universal support and which device distribution is possible. When specifying the device equipment, the different sizes and combination options of the cover plates in the universal support must be taken into account.

Universal support UT3

1. Combination with two cover plates 1/2 division (2x 82.5 mm)
2. Combination of cover plates with 1/3 and 2/3 division (61 mm + 104 mm)
3. Cover plate with 3/3 division (165 mm)



*Can be shortened

The cover plates UT3 P0 and UT34 P0 can be shortened for different installation dimensions. They can thus be used in a variable manner, making storage simpler and more efficient.

Universal support UT4

1. Combination of cover plates with 1/4 and 3/4 division (61 mm + 147 mm)
2. Combination with two cover plates 2/4 division (2x 104 mm)
3. Cover plate with 4/4 division (208 mm)

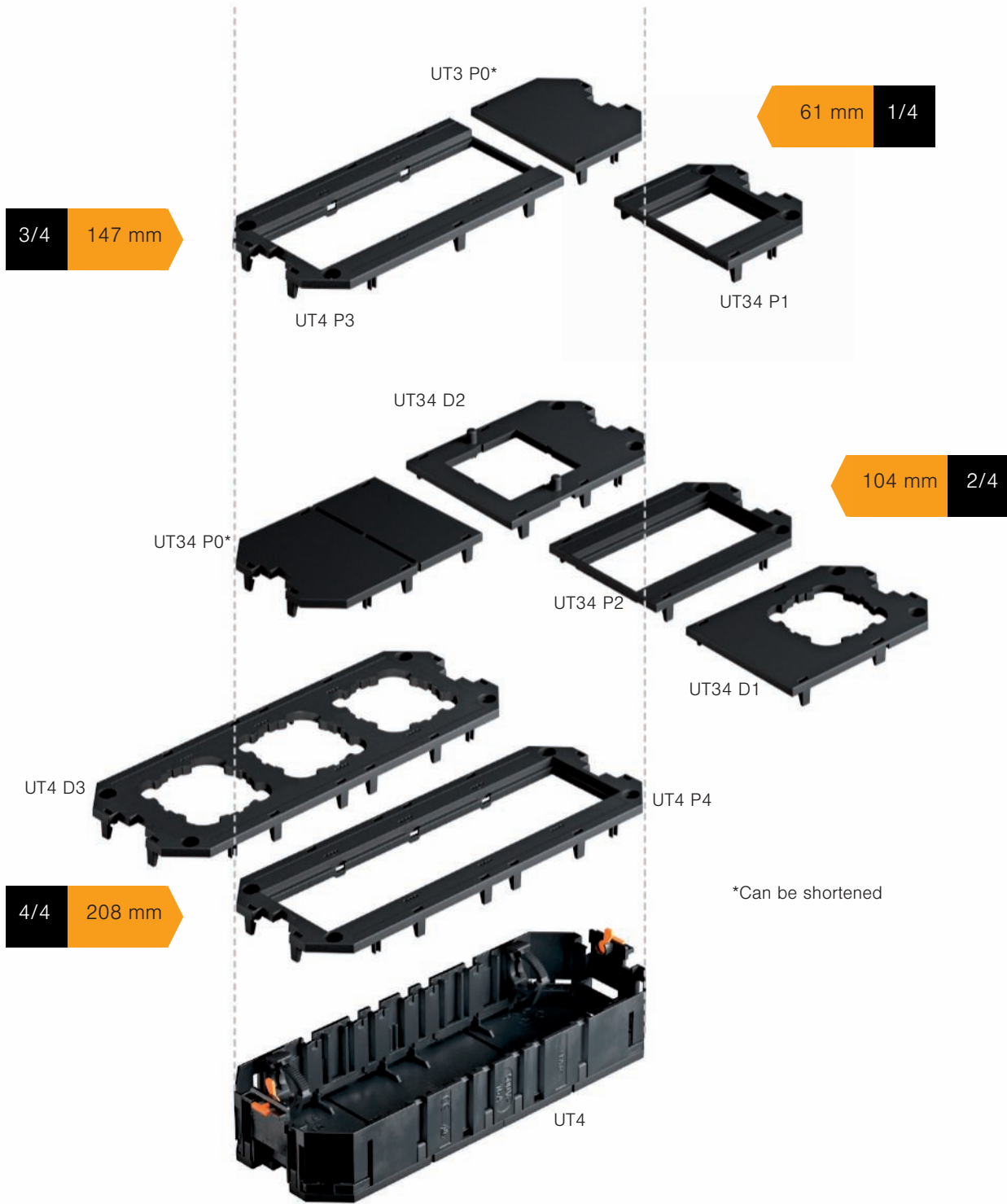

Floor structure height and free space for device use

The minimum floor structure height for the installation of device installation units is primarily dependent on the connector types and sizes used. The required free space is calculated from the dimension between the underside of the lid and the top edge of the universal support.

The universal support can be installed at various heights in the locking ladder of the device installation units. The appropriate free space can be created for this.



If the universal socket has been mounted in the top usable level of the locking ladder, then free space of at least 24 mm is available. This distance is sufficient for the angular connector dimensions, but not, however, for power connectors, straight connectors and USB charging devices. The connector structure heights must be determined for the calculation of the necessary free space.

Installation of multimedia technology

The free space for the installation of data and multimedia technology cannot be clearly determined on account of the many different connector types, sizes and shapes. It must be determined after the connection solution and the connectors have been specified.

Determination of the required free space

The dimensions of the connectors used must be known for the determination of the free space. The minimum free space for use can be calculated using the appropriate corrective measures for the connector types.

Calculation

Connector height (H) + corrective dimension (K) = minimum free space for use

Example

Protective contact angle connector (H) 35 mm – corrective dimension (K) 12.5 mm = 22.5 mm free space when connector is used

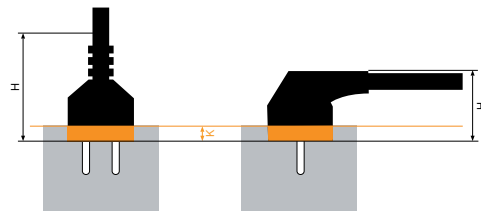

Socket types	Correction dimension (K)
Protective contact	-12.5 mm
With earthing pin	-9.5 mm
British Standard	+5.5 mm
South Africa	+5.5 mm
India	+5.5 mm
China	+5.5 mm
Italy	+5.5 mm
Denmark	-8.5 mm
Switzerland	-8.5 mm

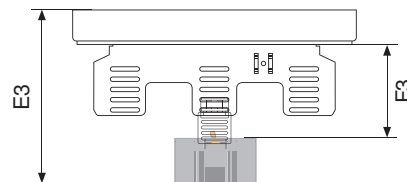
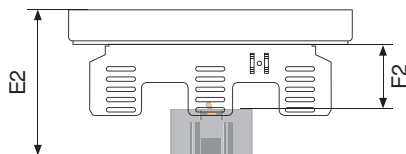
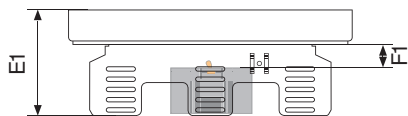

R1 First locking ladder position

The first usable locking ladder position is the basis for the minimum floor structure height during device installation. In this position, socket use with angular connectors is possible when the device installation unit is closed.

R2 Lowest locking ladder position

The lowest locking ladder position relates to the maximum possible lowering of the universal support, without additional components such as the locking ladder extension.

R3 lowest locking ladder position with locking ladder extension

If the locking ladder extension is used, the lowering range of the universal support increases by 26 mm. This makes four additional locking ladder positions available.

			r1	r1	R2	R2	R3	R3
	Floor covering thickness mm	Number of locking ladder positions	Min. installation depth (E1) mm	Free space (F1) mm	Min. installation depth (E2) mm	Free space (F2) mm	Min. installation depth (E3) mm	Free space (F3) mm
GES2, GES4, GESR4, GESR9SR	5	5	73	24	93	44	119	70
GES4-2, GES6-2, GES9-3B, GES9-3S	5 10	6 5*	73 78*	26 26*	98 98	51 46	124 124	77 72
GES6, GESR9	5	6	73	24	98	49	124	75
GESR7, GESR9/10, GESRA9, GESRA7	5 10	5 5	78 78	24 24	98 98	44 44	124 124	70 70
GES4M, GES6M, GES9M	5 10	4 4	78 78	24 24	103 103	49 49	129 129	75 75
GESR9-2	5 10	6 6	76 76	29 24	101 101	54 49	127 127	80 75
GRAF9	-	6	80	29	106	54	132	80
Height-adjustable, cassettes RKN2..., RKSN2..., RKFN2...	20 25	5 5	97 102	25 25	129 134	61 61	155 160	87 87
Height-adjustable cassettes RKR2..., RKS2..., RKFR2...	20 25	5 5	101 101	30 25	131 131	65 60	157 157	91 86
Height-adjustable, decouplable cassettes RKN2..., RKSN2..., RKFN2...	20 25	5 5	90 95	25 25	125 130	61 61	151 156	87 87
Height-adjustable, decouplable cassettes RKR2..., RKSRN2..., RKFRN2...	20 25	5 5	95 95	30 25	130 130	65 60	156 156	91 86

* Use is possible from the second locking ladder.

Modul 45® devices

Modul 45®
Protective contact and earthing pin sockets



Modul 45®
Country-specific sockets



Modul 45®
Switching and protection devices

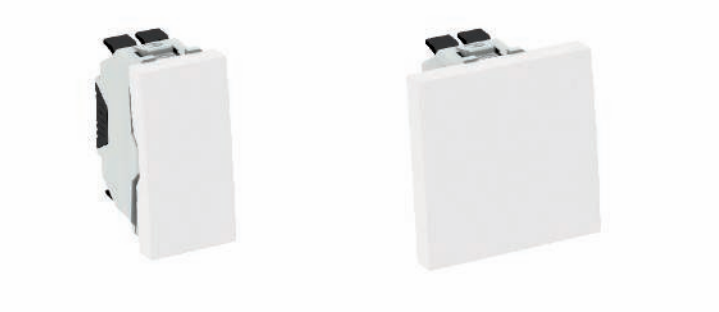

Modul 45®
Data technology



Modul 45®
Multimedia technology





Modul 45®

One system – many solutions

The Modul 45 devices from OBO Bettermann offer the right solution for every application – no matter whether you're dealing with sockets, data or multimedia technology.

- Multiple sockets for economic device installation
- Sockets for international applications
- Modul 45connect sockets for quick, secure installation
- Data technology supports for data modules of different manufacturers
- Multimedia connection solutions for data, video and audio transmission

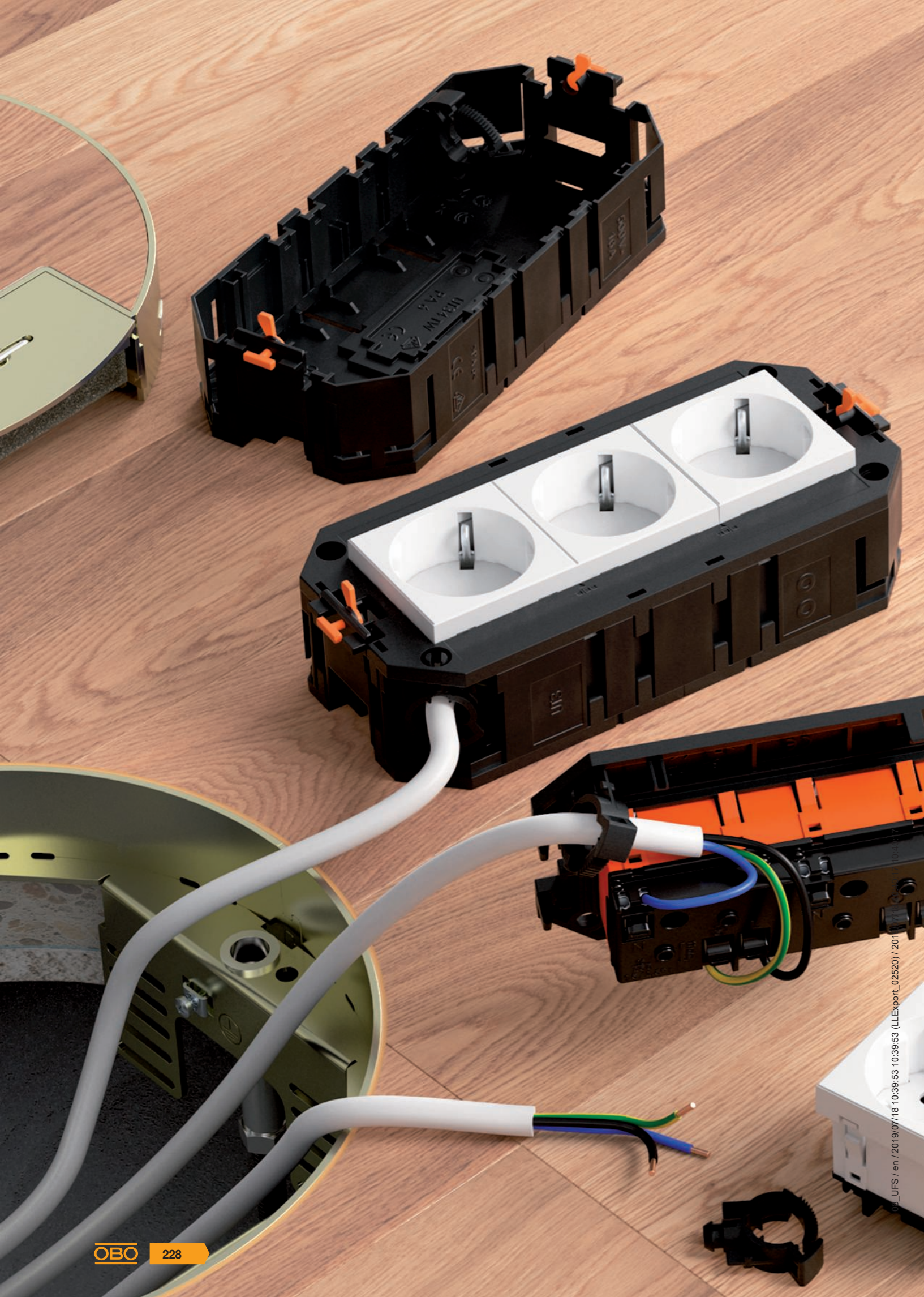

Modul 45[®] – sockets

The installation of Modul 45 sockets is particularly easy: The integrated screwless terminals and the tried-and-trusted locking fastening allow toolless mounting. The wide range of country-specific sockets offers the right solution for any system environment.

Safety power supply

To restrict special power circuits in industrial buildings, the sockets are also available in the colours orange, green and red. This means that, for example in a laboratory, all the requirements of DIN VDE 100 Part 710 can be met.



Multiple sockets

The multiple sockets, double and triple, are particularly economical and time-saving during installation. The lengthy wiring process of individual sockets, as required for standard installations, is no longer necessary.



08_UFS / en / 2019/07/18 10:39:53 (LExport_02520) / 2019

Modul 45® – data technology

Today, we cannot picture offices without data networks. Flexible cabling solutions and data connection modules are used with increasing frequency. OBO can offer various data connection modules, both with and without shielding: Cat. 5e, Cat. 6 and Cat. 6a. The data connection modules are simply snapped into the Modul 45 data technology support.

Modul 45® data technology support

A comprehensive range of data technology supports is available for the installation of connection modules of various data technology manufacturers.



Dust protection

Integrated dust protection flaps cover the connection modules when unused and protect them against dust and other outside influences. During use, the dust protection flaps are pushed upwards. After the connection cable has been removed, the dust protection flaps close again automatically.

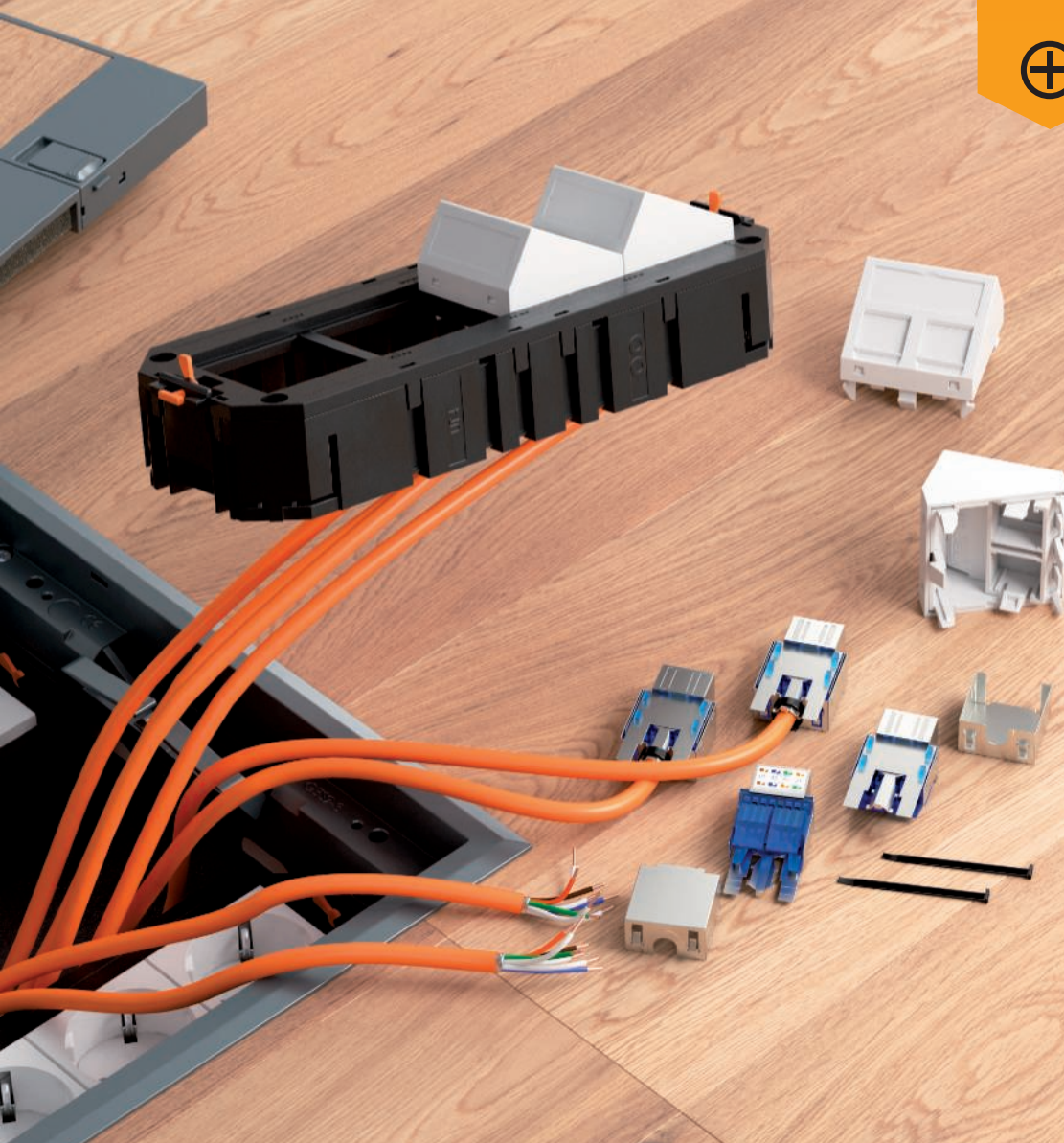

Modul 45® – multimedia

With the multimedia connection solutions, computer, video and audio connections can be installed in the different OBO system environments. No matter whether in the GES service outlet, in cassettes or in System 55 – with the Modul 45 support plate, mounting is easy and quick.

For all standard multimedia applications

The OBO multimedia solutions permit the integration of all standard systems: VGA, DSub9, HDMI, DVI, USB, mini jack, BNC, Cinch for Audio and Video, XLR. A version without a plug connector is available for construction-site equipment (VGA, DSub9, DVI, XLR).



Practical connection solutions

Whether you are routing pre-terminated cables or standard installation cables, we have the right connection solution for every standard connection type.

- Solder connection or screw connection for conventional cable connections
- Connection cable or 1:1 coupling to connect pre-terminated cables

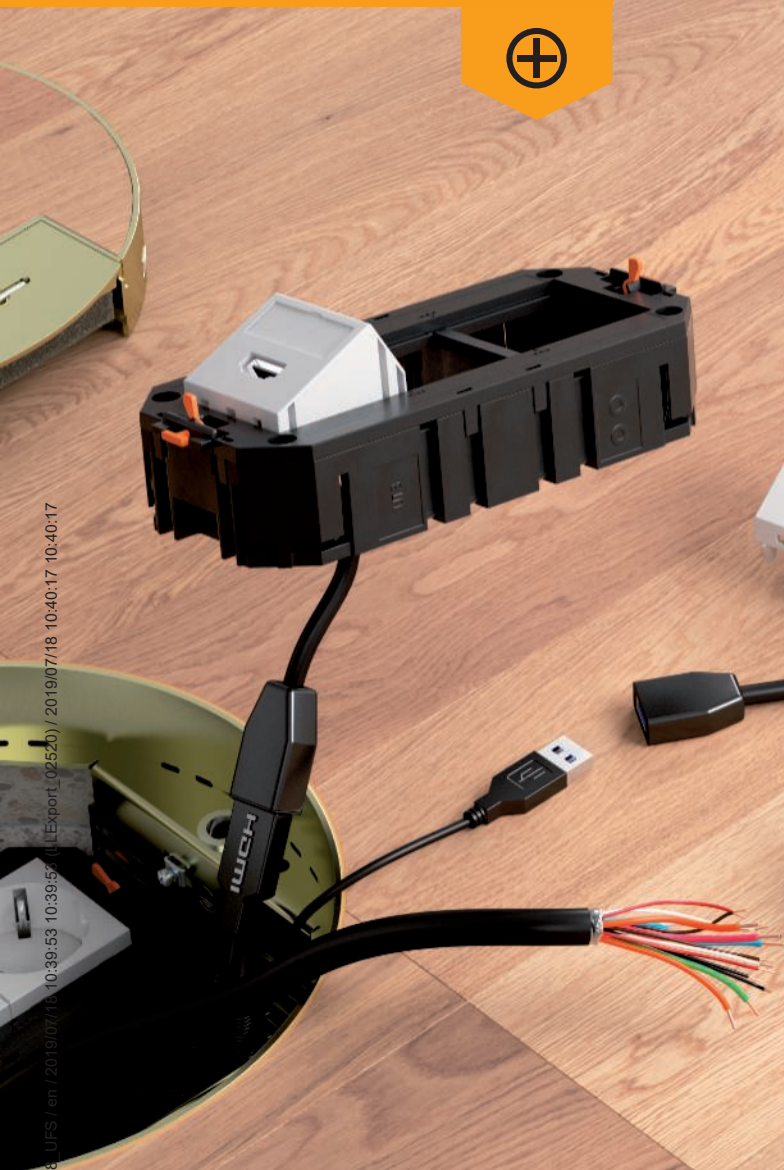

MTK mounting support

The MTK mounting support is designed to accept data and multimedia technology. Data connection modules of different sizes and fastening types can be installed more easily in the mounting support using the matching type MPK mounting plates.

The closed design of the mounting support protects the installation space of the connection cables against access.

The required installation depth (floor structure height) is at least 75 mm. Its exact dimension is dependent on the installation components used and the bend radii of the connection cables.

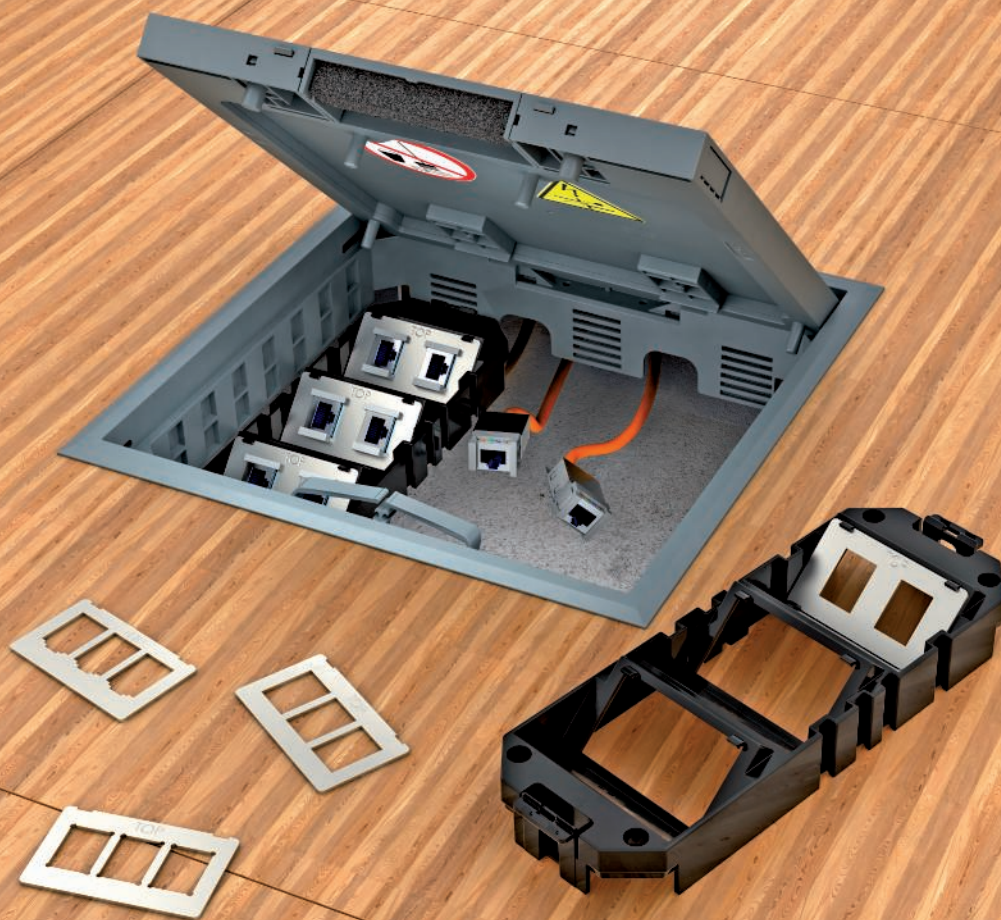

Mounting plates

Mounting plates for various standard connection components are available to accept the data connection modules.



Mounting support

The mounting support is available in two sizes and can accept either two or three mounting plates. No tools are required for mounting: The mounting plates can simply be engaged in the mounting support. The mounting support engages just as easily in the locking ladders of the device installation units.

Laying installation

Module support for vertical device installation

The module support MT45V is designed for the vertical installation of Modul 45 devices and can be used in service outlets and cassettes of nominal size 9 and R9. The module support offers space for a maximum of eight Modul 45 devices and can be equipped flexibly with sockets, data and multimedia technology. The necessary installation depth (floor structure height) is dependent on the device installation unit used and, for a GES9 service outlet, is at least 73 mm.

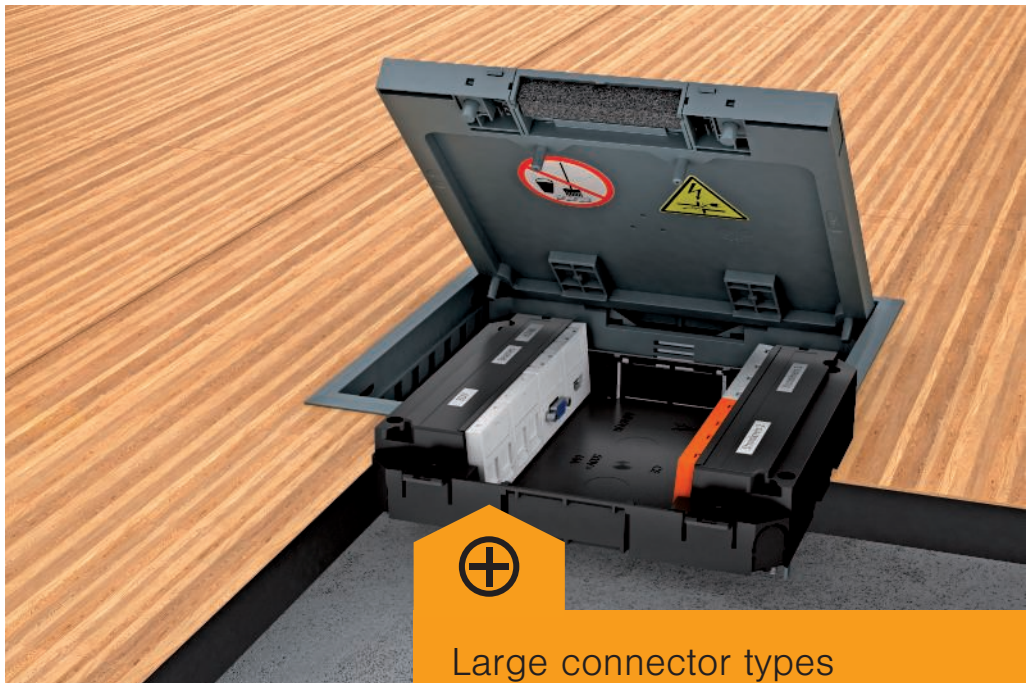

Large connector types

Connection cables with large connectors (e.g. XLR, DVI) can be installed with the module support, even at low floor structure heights.



CEE installation

CEE sockets can easily be used in rooms with wet-cleaned floors, when they are installed in a tube body cassette or the GRAF9 service outlet. The CEE connector is run through the tube body opening to the device connection. Even if the cable is run out, the installation space is protected against the ingress of moisture.

Device support GT

The GT device support is designed for the installation of CEE connection units in service outlets and cassettes. Due to the large dimensions of the CEE connection system, a minimum installation depth (floor structure height) of 190 mm is required for installation and use.



Modul 45connect® – plug-in installation solutions for raised and cavity floors

The Modul 45connect for underfloor systems is a continuous, connectable installation technology. This is designed for installation in a system floor. Modul 45connect offers the highest level of flexibility, security and cost efficiency.

The system offers all the required installation components: From energy distribution through to device connection in the floor box.

Raised floor installation



Rapid and toolless installation through Modul 45connect



More safety through pre-terminated and tested systems



Simple reinstallation and the highest flexibility



Reduction of the fire load



Cavity floor installation

28_UFS / en / 2019/07/18 10:39:56 (LLExpert_02520) / 2019/07/18 10:40:17 10:40:17

Plug-in device installation solution for raised and cavity floors

Modul 45connect®
Universal supports + sockets

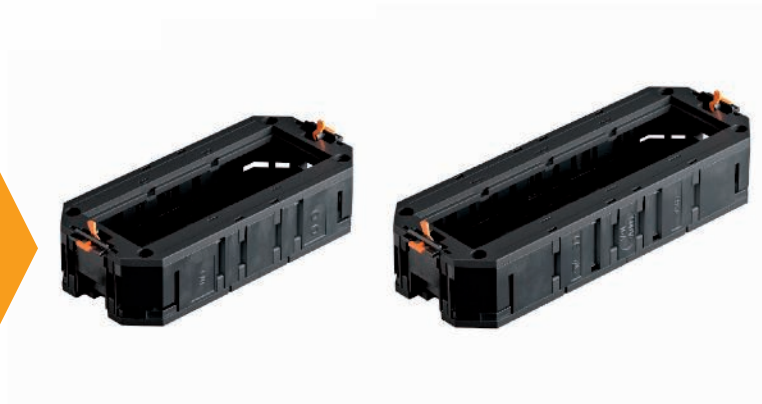

Modul 45connect®
Connection + adapter

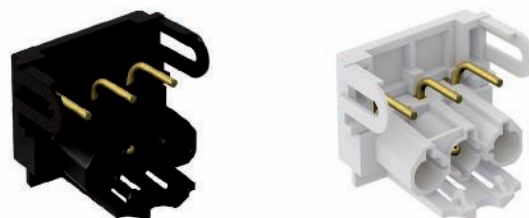

Ready-for-connection
socket units



UVS energy distributors



Installation accessories
and connection cables



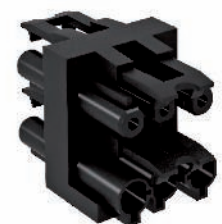
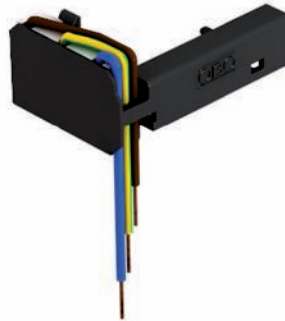
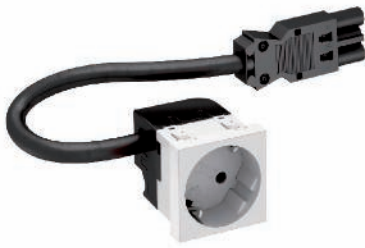

Plug-in connection unit

The ready-for-connection connect UTC universal supports are equipped with connectable connection adapters. The cables are connected directly to the underfloor distributors via connection cables.



Raised floor systems

Raised floor systems offer the highest flexibility in the use and planning of office workspaces. This flexibility can be used to the utmost through the use of plug-in connection solutions.

If there are changes of use, floor plates including the floor box can be adapted to the new room planning with little effort – disconnect the pre-terminated connection cable and connect it to the connection unit in the new position.

Energy distributor

Energy distributors are used in raised floors with removable floor plates. They are mounted at central points under the floor surfaces and supply the installed floor boxes in a star shape.





Service outlets

All the service outlets from the standard product range can be used in raised and cavity floors. The GES service outlets are available in round and rectangular versions. Plastic or metal are used as materials. The plastic version is the tried-and-trusted solution for office installations. It is available in three colour variants. The metallic stainless steel or aluminium versions look refined and can carry an even greater load.

Other solutions are available for areas with increased floor load requirements.

Ready-for-connection universal support connect UTC

The connect UTC universal supports can be ordered as a ready-for-connection unit or freely terminated according to customer requirements.

Combinations of up to two circuits are possible for each connection unit – also with surge protection.





Connection in the floor box

The plug connections on the Modul 45connect sockets are located below the connection unit. This allows plug connections outside the floor box. The connected universal support is installed in the floor box by lowering it in the locking ladder. Fastening in the floor box is carried out using the sash locks in the locking ladder.

Cavity floors

Cavity floors have a support layer of a joint-free, poured screed plate. The installation opening for the installation of floor boxes can be created in two ways in the cavity floor: Either the installation opening is created with a lined body before the screed work or core drilling takes place after the screed work.

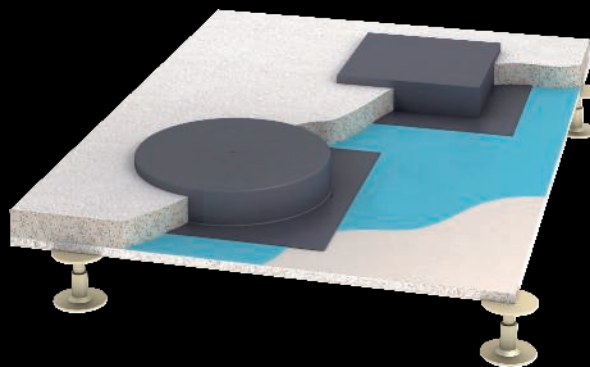

Cable routing

Beneath the screed plate, supply points for the installed floor boxes are set using energy distributors.

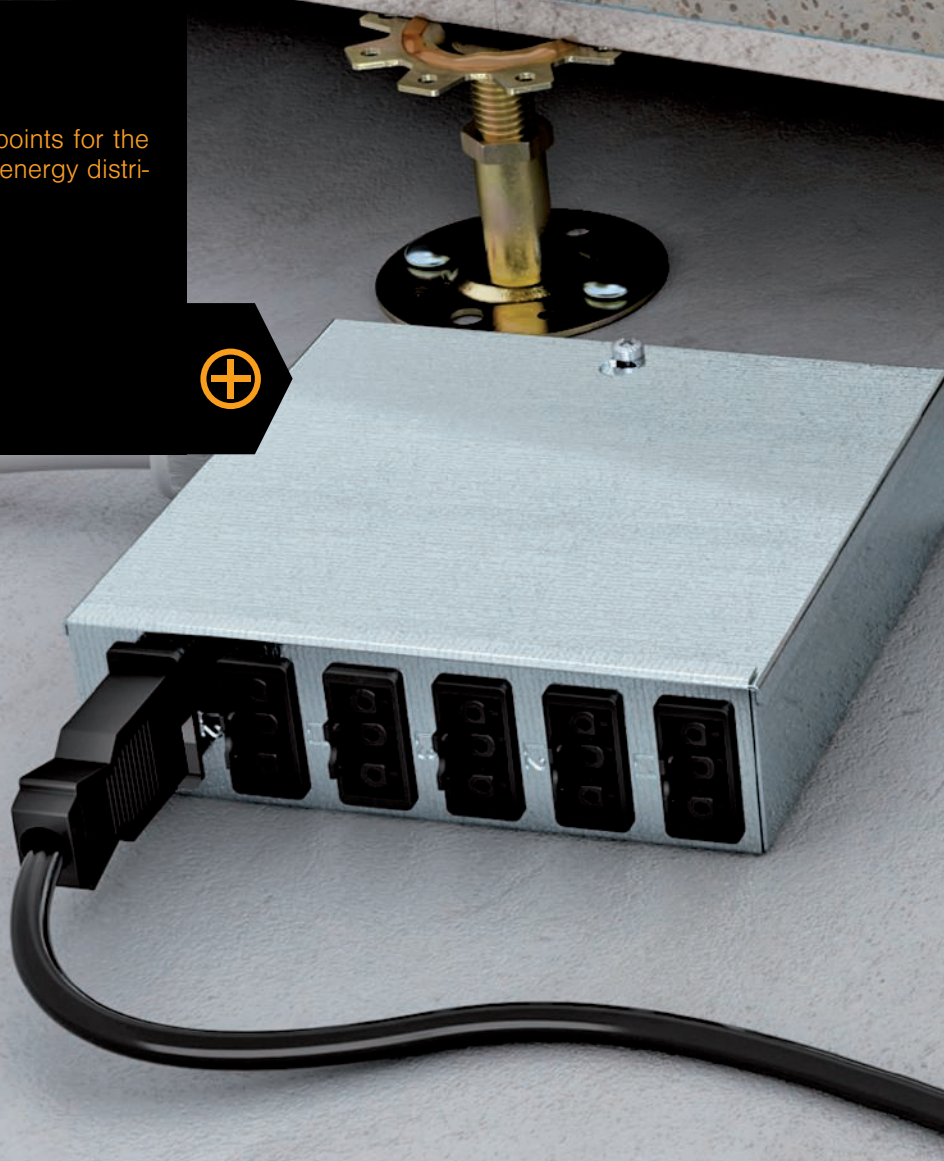



08_UFS / en / 2019/07/18 10:39:53 10:39:53 (LLExpert_02520) / 2019/07/18 10:40:17 10:40:17



Cassettes

The compact, flush-floor cassettes from Ackermann made by OBO offer power, data and multimedia connections in the smallest areas. The cassettes can be adjusted to the height of the floor and are available in round and rectangular designs. There are versions for dry, moist and wet-care floor coverings.

Installation benefits Modul 45connect®

Modul 45connect sockets can be mounted and connected with just a few actions. The GST18 adapters are engaged to the side of the sockets – incorrect installation is not possible due to the coding of the locking connections.

⊕ Connection adapter for 4x socket combination

The connection of Modul 45connect sockets is really easy: A plug connection is created using a connection adapter. There is no need for the otherwise necessary wiring work, considerably reducing the time required for mounting. This means that combinations of two double sockets in the UT4 universal support can be created rapidly.

Connection adapter

An angled connection adapter with integrated strain relief is available especially for use in service outlets and cassettes. The connection adapter is available for the isolation of circuits in two colours (black and white).



Two circuits

Combinations with two power circuits with triple, double and single sockets in UT universal supports are possible. In addition, the use of surge protection modules is also possible on double and triple sockets.

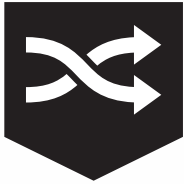

Rapid and toolless installation through Modul 45connect



Safe installation through encoded connection technology



Direct mounting in the trunking – without additional components



Reduction of the fire load

Consolidation Points offer a high level of flexibility and combination options for power, data and multimedia connections.

The electrical supply is possible via both the Modul 45 sockets and the plug connector systems. In the housing, cover hoods can be used to separate the different sockets and to separate the power and data technology.

Data and multimedia technology can be installed in the housing conventionally or with pre-terminated data cables.

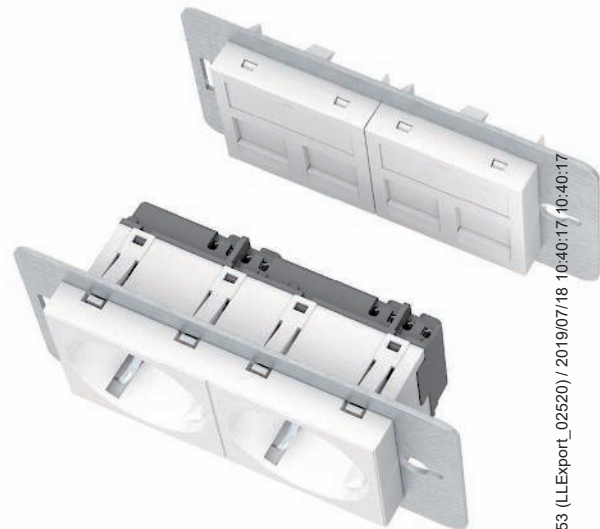

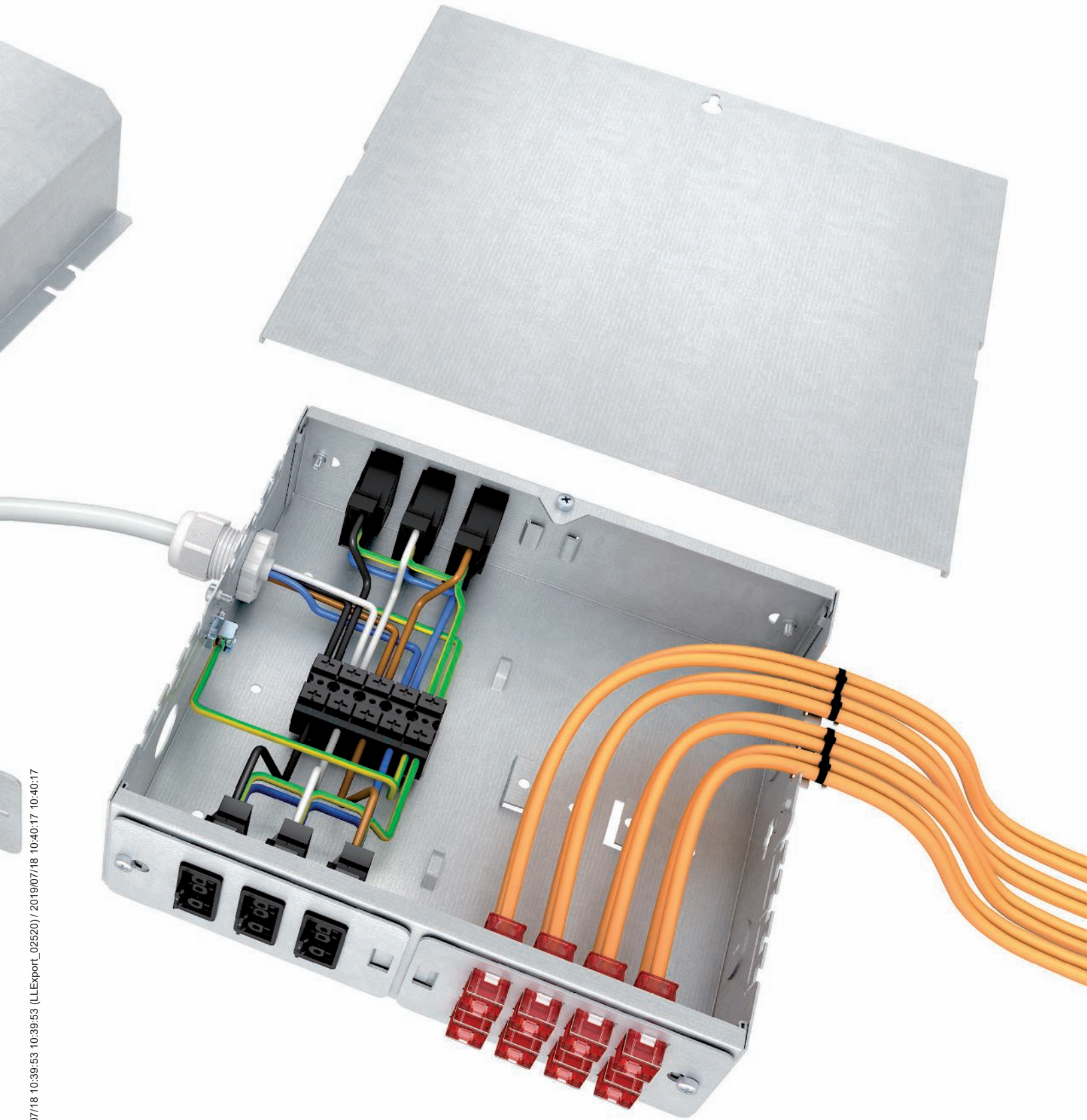

Modular structure

System components

1	Universal supports
2	Modul 45connect connector part adapter
3	Protective contact socket
4	Modul 45connect connector



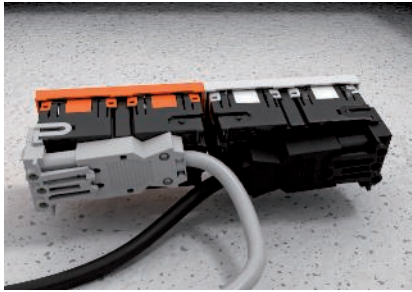

Safe

The Modul 45connect system is ideally suited for use in raised floors. Ready-for-connection module supports need only be connected to the heavy current cabling.

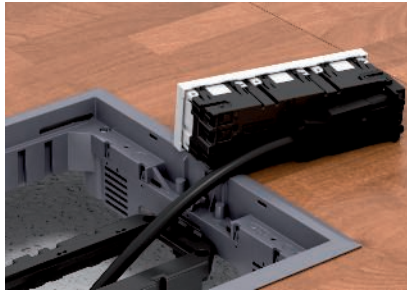

Cost-aware

The Modul 45connect system makes lengthy manual cabling work a thing of the past. All the connections can be created simply, quickly and safely using terminated components.



Plug connections

All the plug connections are equipped with the GST18i connector systems and strain relief. Black and white connectors and cable colours are suitable for labelling the different circuits. Connection cables with cross-sections of 1.5 mm² or 2.5 mm² and a wide range of plug connectors offer the right solution for every requirement.

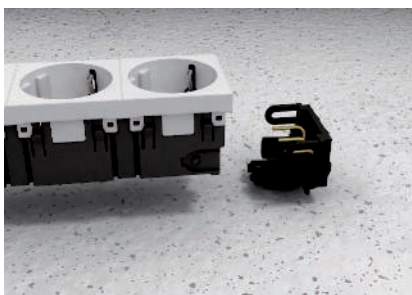

Connection adapters

The connection adapters can be connected to the socket outside the universal support. The socket unit with connection adapter is then engaged in the universal support.

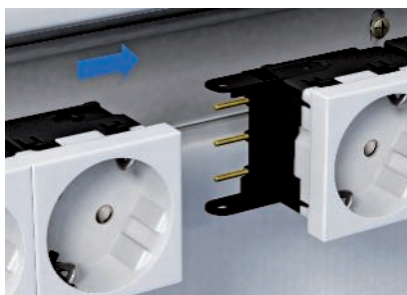

Connection adapter, socket

Modul 45connect sockets can be connected with a connection adapter. The simple plug connection removes the wiring work.

Fire protection in underfloor systems

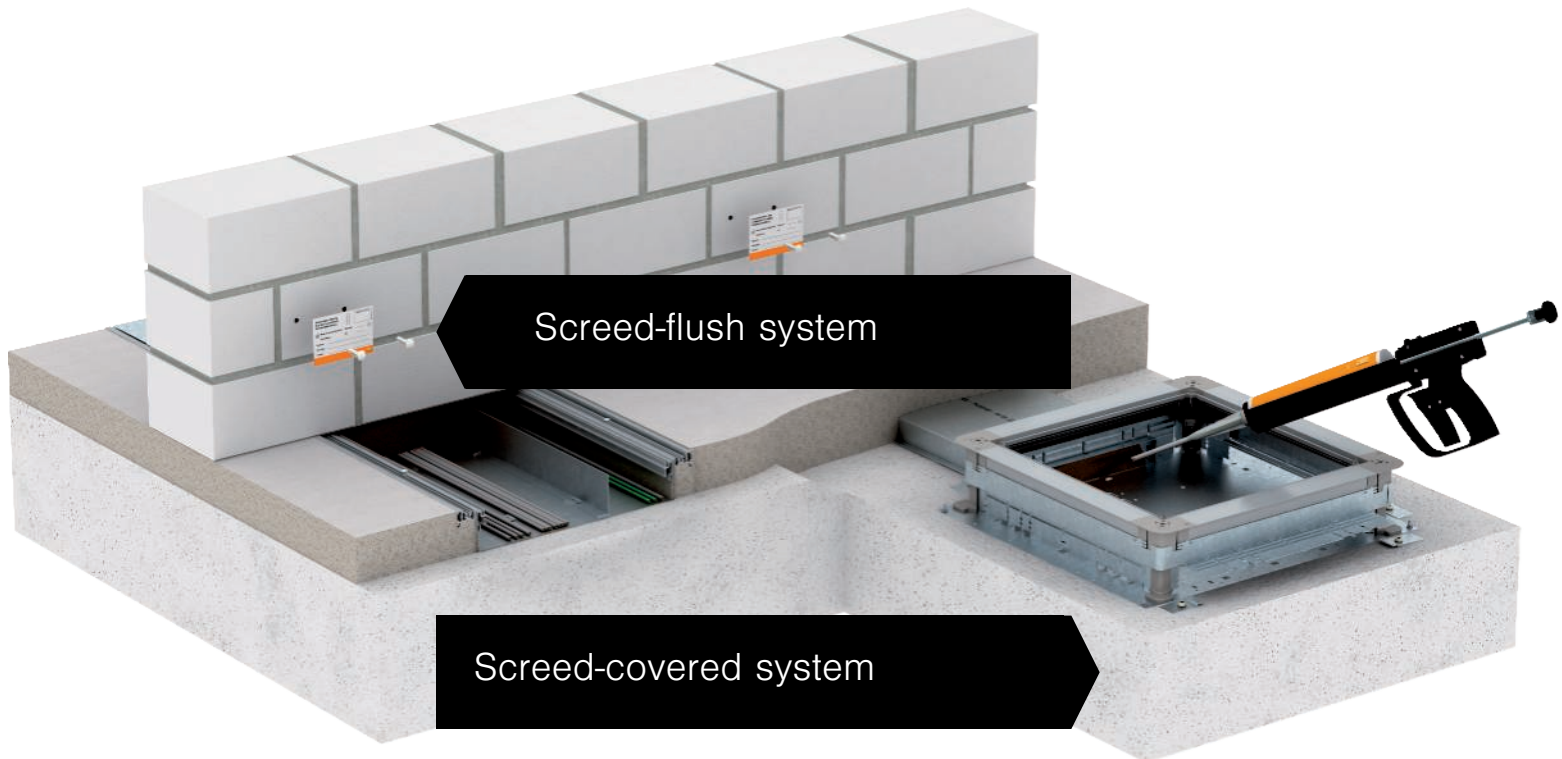

System floors directive

The master system floors directive (MSysBöR) is of key significance for fire protection measures in underfloor systems. This directive is a supplement to the Master Cable Systems Directive (MLAR). The MLAR describes the fire protection requirements for the penetration of cables through classified walls and ceilings, the fireproof installation in emergency and escape routes and requirements for electrical function maintenance. In these validity areas, the three protection aims must be implemented: Protect fire sections, secure escape routes and maintain electrical functionality.

Focus on emergency and escape routes

The system floors directive deals primarily with the installation of underfloor systems in emergency and escape routes (see also MLAR, Section 3.2.1). However, other rooms of a building may be subject to fire protection requirements for the system floors.

System floors

System floors are primarily approved in the necessary staircases, in rooms between necessary staircases and exits to the open air, as well as in the necessary corridors and other rooms. System floors are forbidden in safety stairwells.

The system floors directive distinguishes between cavity floors and raised floors. Whilst cavity floors have a poured support layer made of screed, with a maximum cavity of 200 mm, raised floors are made of prefabricated support plates on a stand structure.

Poured floors

In most emergency and escape routes, poured floors are used. If underfloor systems are used here to supply electrical energy, then these ducts and trunking must fulfil certain requirements. Only inspection openings are permitted in these areas.

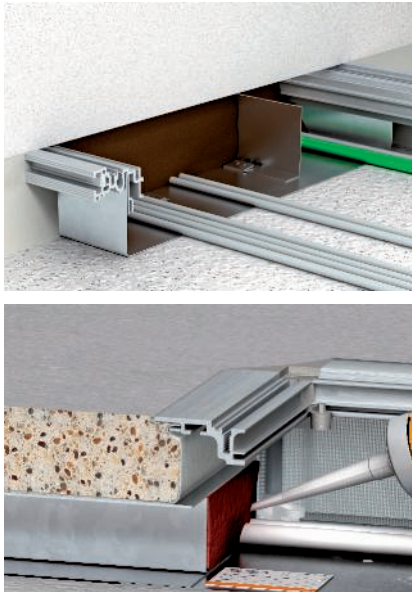

Fig. Transition from raised floor to escape route with PYROCOMB® Intube CTS-HP200 insulation

Screed-covered duct systems EÜK

If there are screed-covered ducts in emergency and escape routes, then the same requirements apply to them. The inspection sockets may not contain installations and must also be smoke gas-tight and closed off with non-combustible covers. OBO EÜK systems fulfil these requirements.

Open trunking systems OKA

Open trunking systems may be routed in emergency and escape routes, if the trunking is closed so that they are smoke-tight with non-combustible covers, e.g. sheet steel lids and surrounding seals. The seal can be made from foam rubber, which does not have any negative impact if there is a fire, on account of the small quantity installed. However, installations are not permitted in the trunking. The OBO OKA underfloor trunking fulfils all the requirements of the MSysBöR directive.

Underfloor ducts under fire protection-classified walls

If underfloor ducts run beneath walls with a fire resistance period, then insulation measures must be taken to prevent the spread of a fire. OBO Bettermann can offer various systems for this.

If raised floors abut onto, for example, escape routes with poured screed floors, then there must be at least partial insulation beneath the smoke protection door or fire protection door. In most cases, the insulation can only be worked from one side. In such cases, the half shell of type CTS-HP200 from the PYROCOMB® Intube insulation system is an ideal solution. The half shell is self-adhesive and is only sealed on one side. It offers fire resistance up to EI 120 according to EN 13501-2.

Screed-covered underfloor ducts are insulated starting from the closest connection sockets, as the wall opening can no longer be reached directly due to the poured screed. The distances between the connection sockets are irrelevant. This is a smoke gas-tight and fire-proof closure, in order to prevent the spread of fire. The PYROSIT® NG fire protection foam is approved as an OBO fire protection system. This is pressed from the connection socket directly into the duct compartments.

With open trunking, the wall opening must be reached. In these cases, the PYROPLUG® Block foam blocks are mounted in the trunking directly under the wall, thus forming a fireproof termination.

Fire protection in system floors



Fire protection requirements for system floors in other rooms

Outside the emergency and escape routes, system floors only have few fire protection requirements placed on them. The fire loads installed beneath the floor are assigned fully to the room.

With raised floors of a height greater than 500 mm, the support structure must have a fire resistance period of 30 minutes (F30). This is intended to prevent the rescue teams of the fire brigade from falling through the floor.

Raised floors, also those used for room ventilation, must be equipped with smoke detectors. These must ensure that the ventilation system is switched off.



PYROLINE® Rapid

The ideal solution for system floors is the OBO PYROLINE® Rapid fire protection duct, made of internally coated sheet steel.

To minimise the risk of fire through the electrical installation, cables are routed beneath the raised floor in fire protection ducts. If there is a cable fire, these classified I ducts ensure that the fire and smoke cannot spread unimpeded in the raised floor.

Metal materials

Alu — Aluminium

AlG — Cast aluminium

VA (1.4301) — Stainless steel, grade 304

VA (1.4303) — Stainless steel, grade 305

CuZn — Brass

St — Steel

Zn — Die-cast zinc

Plastic materials

HP — Hard cardboard

MGUM — foam rubber

PA — Polyamide

Temperature resistance:
permanently up to approx. 90 °C, briefly up to about 130 °C
and to about minus 40 °C*.

Chem. resistance generally as for polyethylene.

Resistant to

Petrol, benzene, diesel oil, acetone, solvents for paints and lacquers,
oils and greases.

Unstable with

Bleach, most acids, chlorine.

Risk of tension cracking

Low in air-humid conditions; only with some aqueous salt solutions.
Highly desiccated parts (high temperature and extremely low air
humidity) are highly sensitive to fuels and various solvents.

PVC — Polyvinylchloride

Temperature resistance:
permanently up to 65 °C, briefly up to 75 °C and to about minus 30
°C.

Resistant to

Weak acids, alkalis, oils and greases, petrol.

Unstable with

Strong acids, benzene, acetone, iodine, toluene, trichloroethylene.

Risk of tension cracking

Low, only with some solvents such as benzene and acetone.

PS — Polystyrene

Temperature resistance:
Because of its relatively high sensitivity to the effects of chemicals, its
use is not recommended at temperatures above normal room
temperature, about 25 °C.

Resistance to cold: to about minus 40 °C*.

Resistant to

Alkalis, most acids, alcohol.

Conditionally resistant to

Oils and greases.

Unstable with

Butyric acid, concentrated nitric acid, concentrated acetic acid,
acetone, ether, petrol and benzene, solvents for paints and lacquers,
chlorine, diesel fuel.

Risk of tension cracking

Relatively high.

Stress cracks can be caused by, amongst other things, acetone, ether,
petrol, cyclohexane, heptane, methanol, propanol and the softeners
used in some PVC cable mixes.

PC/ABS — Polycarbonate/Acrylonitrile-butadiene- styrene

Temperature resistance:
minus 30 °C to 90 °C, briefly up to approx. 105 °C, melting range at
approx. 200 °C, thermal decomposition at 300 °C. Material
thicknesses of 1.5 mm or more can achieve UL94 V-0. At material
thicknesses of 1 mm or more, the glow wire temperature of 960 °C
according to IEC 60695-2-12 is achieved.

Resistant to

Mineral acids, organic acids and aqueous salt solutions

Conditionally resistant to

Alkalis, hydrocarbons, aromatics and (in trace form) a series of
greases and oils.

PC — Polycarbonate

Temperature resistance:
permanently up to approx. 110 °C (in water 60 °C), briefly up to
125 °C, and to below minus 35 °C.

Resistant to

Petrol, turpentine, most weak acids.

Unstable with

Acetone, benzene, chlorine, methylene chloride, most concentrated
acids.

Risk of tension cracking

Relatively low.

Media which can cause tension cracking include benzene, aromatic
hydrocarbons, methanol, butanol, acetone, turpentine.

*The minus values apply only for parts in the quiescent condition with
no severe impact stress.

There is no plastic that is resistant to every chemical. The agents listed
are only a small selection. Plastic parts are especially at risk in the
presence of chemicals and high temperatures. Stress cracks may
occur. If in doubt, please consult us and/or ask for a detailed chemical
resistance table.

Stress crack formation: stress cracks may occur if plastic parts under
tension are exposed to chemicals at the same time. Parts made of
polystyrene and polyethylene are particularly susceptible. Stress cracks
may even be caused by agents to which the plastic in question is
resistant in the absence of stress. Typical examples of parts under
constant stress when used as intended: grip clips, intermediate
supports of cable glands, ribbon clips.

Classification to EN 50085-1

		Screed-covered: EÜK ducts	Screed-flush: EÜK sockets, DUG, etc.	Screed-flush systems, OKA	Screed-flush systems, EBK	On-floor systems	GES service outlets	Height-adjustable cassettes	Frame cassettes	Heavy-duty support (UZD + cassettes)
		EÜK	UZD	OKA	EBK	AIK	GES	RK.N	RK	.SL
6.1	According to material									
	Under consultation									
6.2	According to impact resistance for installation and application									
6.2.1	Electrical installation duct systems for impact energy 0.5 J.									
6.2.2	Electrical installation duct systems for impact energy 1 J.									
6.2.3	Electrical installation duct systems for impact energy 2 J.									
6.2.4	Electrical installation duct systems for impact energy 5 J.						x	x	x	x
6.2.5	Electrical installation duct systems for impact energy 20 J.	x	x	x	x	x				
6.3	According to temperature, as specified in the tables 1, 2 and 3									
Table 1	Minimum storage and transport temperatures ± 2 °C									
	-45									
	-25	x	x	x	x	x				
	-15						x	x	x	x
	-5									
Table 2	Minimum installation and application temperatures ± 2 °C									
	-25									
	-15									
	-5									
	+5	x	x	x	x	x	x	x	x	x
	+15									
Table 3	Maximum application temperatures ± 2 °C									
	+60	x	x	x	x	x	x	x	x	x
	+90									
	+105									
	+120									

Classification to EN 50085-1

		Screed-covered: EÜK ducts	Screed-flush: EÜK sockets, DUG, etc.	Screed-flush systems, OKA	Screed-flush systems, EBK	On-floor systems	GES service outlets	Height-adjustable cassettes	Frame cassettes	Heavy-duty support (UZD + cassettes)
		EÜK	UZD	OKA	EBK	AIK	GES	RK.N	RK	.SL
6.4	According to the resistance against fire spread									
6.4.1	Electrical installation duct systems which permit the spread of fire						x	(x)	(x)	
6.4.2	Electrical installation duct systems which do not permit the spread of fire	x	x	x	x	x				x
6.5	According to the electrical conductivity									
6.5.1	Electrical installation duct system with electrical conductivity	x	x	x	x	x	x 2)	x	x	x
6.5.2	Electrical installation duct system without electrical conductivity						x 1)			
6.6	According to the electrical insulation property									
6.6.1	Electrical installation duct system without electrical insulation property	x	x	x	x	x	x 1)			x
6.6.2	Electrical installation duct system with electrical insulation property						x 2)	x	x	
6.7	According to the protection ratings offered by the housing or casing to EN 60529:1991									
6.7.1	According to protection against ingress of solid foreign bodies	x	x	x	x	x	x	x	x	x
6.7.2	According to protection against ingress of water		x	x				x	x	x
6.7.3	According to protection against contact with dangerous parts						x	x	x	x

1) Applies to polyamide service outlets 2) Applies to metal service outlets

Classification to EN 50085-2-2

		Screed-covered: EÜK ducts	Screed-flush: EÜK sockets, DUG, etc.	Screed-flush systems, OKA	On-floor systems	GES service outlets	Height-adjustable cassettes	Heavy-duty support (UZD + cassettes)	Frame cassettes	Heavy-duty support (UZD + cassettes)
		EÜK	UZD	OKA	AIK	GES	RK.N	.SL	RK	.SL
6.101	Depending on the type of floor care									
6.101.1	Electrical installation duct systems for dry floor cleaning									
6.101.2	Electrical installation duct systems for wet floor cleaning when the service outlet is not in use		x				x	x	x	x
6.101.3	Electrical installation duct systems for wet floor cleaning when the service outlet is in use		x				x	x	x	x
6.102	According to resistance to vertical loads affecting a small surface area									
6.102.1	Electrical installation duct systems for 500 N									
6.102.2	Electrical installation duct systems for 750 N	x								
6.102.3	Electrical installation duct systems for 1,000 N									
6.102.4	Electrical installation duct systems for 1,500 N				x					
6.102.5	Electrical installation duct systems for 2,000 N					x				
6.102.6	Electrical installation duct systems for 2,500 N									
6.102.7	Electrical installation duct systems for 3,000 N		x	x			x		x	
6.103	According to resistance to vertical loads affecting a large surface area									
6.103.1	Electrical installation duct systems for 2,000 N									
6.103.2	Electrical installation duct systems for 3,000 N						x			
6.103.3	Electrical installation duct systems for 5,000 N					x			x	
6.103.4	Electrical installation duct systems for 10,000 N									
6.103.5	Electrical installation duct systems for 15,000 N		x					x		x



OBO Bettermann Holding GmbH & Co. KG
P.O. Box 1120
58694 Menden
GERMANY

Customer Service
Tel.: +49 23 73 89 - 17 00
Fax: +49 23 73 89 - 12 38
export@obo.de

www.obo-bettermann.com

Building Connections

